

# Operating instructions

**Air cooling unit GIK  
with direct driven centrifugal fans; refrigerant NH<sub>3</sub>**

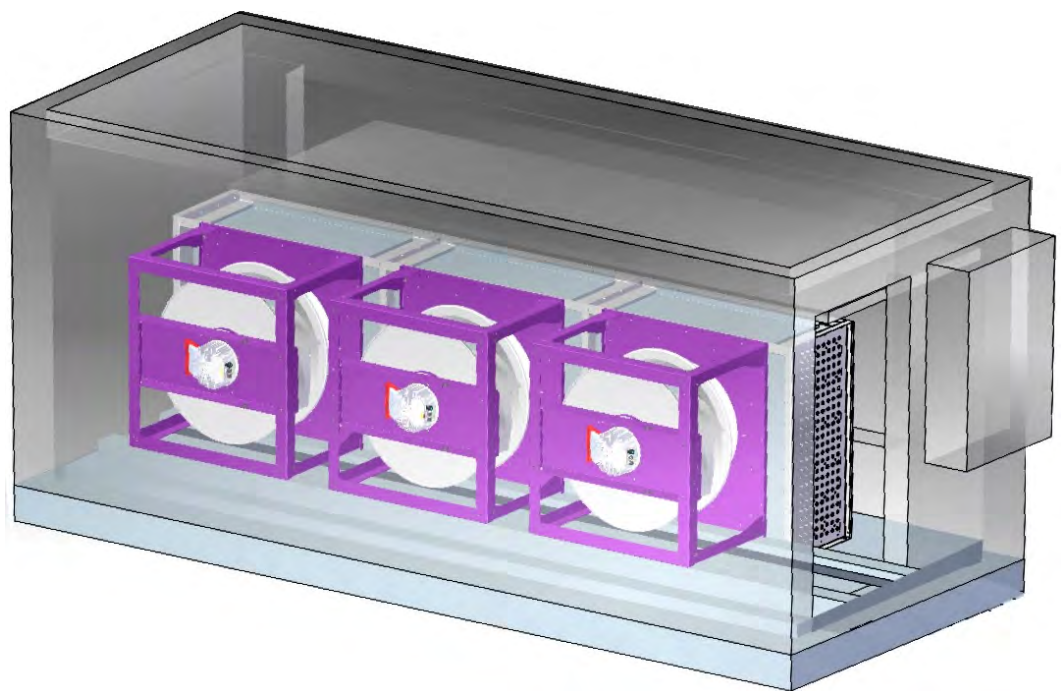

Translation of the original operating instructions

Any work on and with this machine may only be carried out by competent personnel!

**Read the operating instructions before starting any work!**



Projekt-ID: Doc 225  
Rev.-Stand: 2014-09-08  
© Güntner GmbH & Co. KG  
Hans-Güntner-Str. 2 - 6  
D-82256 Fürstenfeldbruck

Tel.: +49 8141 242 0  
Fax: +49 8141 242 155

E-Mail: [guentner@guentner.net](mailto:guentner@guentner.net)  
Internet: [www.guentner.de](http://www.guentner.de)

---

<b>List of revisions.....</b>	<b>7</b>
<b>1 Information on the operating instructions .....</b>	<b>8</b>
1.1 General details .....	8
1.2 Using the operating instructions .....	9
1.3 Symbols, abbreviations, terms .....	9
1.4 Symbol definition .....	11
1.5 Limitation of liability.....	15
1.6 Customer service.....	16
1.7 Conformity declaration.....	16
1.8 Copyright protection.....	16
<b>2 Safety.....</b>	<b>17</b>
2.1 Use according to intended purpose .....	17
2.2 Incorrect use .....	17
2.3 Responsibilities .....	18
2.3.1 Responsibility of the operator.....	18
2.3.2 Responsibility of the personnel.....	19
2.4 Personnel requirements.....	20
2.4.1 Safety requirements .....	20
2.4.2 Qualification requirements .....	20
2.4.3 User requirements.....	21
2.4.4 Instruction .....	21
2.4.5 Unauthorised persons.....	22
2.5 Personal protective equipment .....	22
2.6 Dangers .....	24
2.6.1 Risks due to mechanic dangers .....	24
2.6.2 Risks due to electric dangers .....	27
2.6.3 Risks due to thermal dangers.....	28
2.6.4 Hazards due to vibration .....	29
2.6.5 Risks due to materials and substances.....	30
2.6.6 Risks due to neglected ergonomic principles .....	32
2.6.7 Hazards due to operation environment.....	32
2.7 Hazardous substances .....	33
2.8 Environmental protection .....	34
2.9 Fire and explosion protection .....	35
2.10 Safety installations.....	36
2.11 Protection against restart .....	37
2.12 Spare parts, usage and purchase.....	38
2.13 Behaviour in case of hazards and accidents .....	38
2.14 Signage .....	39



# Content

---

<b>3</b>	<b>Technical data</b> .....	<b>41</b>
3.1	Entire machine .....	41
3.1.1	Rating plate.....	41
3.1.2	Type key for machine name (device name) .....	41
3.1.3	Dimensions and weights.....	41
3.2	Evaporator .....	42
3.2.1	Evaporator - General information .....	42
3.2.2	Evaporator - Construction data .....	42
3.3	Installation conditions .....	42
3.4	Operating conditions.....	43
3.4.1	Permissible ambient conditions.....	43
3.4.2	Operating conditions relevant for monitoring Machine.....	43
3.4.3	Emissions .....	43
3.4.4	Time operating conditions.....	43
3.5	Interfaces .....	44
3.6	Electrical connection.....	45
3.6.1	Requirements on the electricity supply .....	45
3.6.2	Residual current protective devices.....	45
3.6.3	Electrical specifications for fans .....	45
3.6.4	Electrical and other specifications for flaps and drives.....	45
<b>4</b>	<b>Structure and function</b> .....	<b>46</b>
4.1	Short description .....	46
4.2	Function diagram .....	46
4.3	Exterior view .....	47
4.4	Overview of operating elements.....	48
<b>5</b>	<b>Transportation</b> .....	<b>49</b>
5.1	Safety instructions regarding the transport.....	49
5.2	Transport inspection.....	50
5.3	Transportation symbols .....	50
5.4	Transporting and storing the machine .....	51
5.4.1	Storing the transported goods.....	51
5.4.2	Handling the packaging.....	51
5.4.3	Transport on-site.....	52
5.4.3.1	Remove the transported goods from the container.....	52
5.4.3.2	Use lifting equipment to transport the transported goods .....	52
5.4.3.3	Use material handling equipment to transport the transported goods.....	53



<b>6</b>	<b>Installation.....</b>	<b>54</b>
6.1	Setup .....	56
6.1.1	Requirements and preparations for assembly.....	56
6.1.2	Floor installation .....	56
6.1.3	Installing general additional components .....	57
6.1.4	Installation and configuration of additional hydraulic components.....	57
6.1.5	Installing piping.....	58
6.1.6	Welding or soldering piping.....	58
6.2	Air duct connection .....	59
6.3	Fan final assembly.....	59
6.4	Electrical connection.....	60
6.4.1	Preparatory inspections and installations.....	61
6.4.2	Establish the electrical connection.....	62
6.4.3	Establish the signal connections .....	62
<b>7</b>	<b>Start-up.....</b>	<b>63</b>
7.1	Preparing for the acceptance test.....	63
7.2	Carrying out the acceptance test.....	64
7.3	Checking operational readiness .....	65
7.4	Starting up for the first time .....	65
<b>8</b>	<b>Operation.....</b>	<b>66</b>
8.1	Safety instructions regarding operation.....	66
8.2	Emergency shutdown .....	66
8.3	Overview of operating elements .....	67
8.4	Switching on and off .....	67
<b>9</b>	<b>Failures.....</b>	<b>69</b>
9.1	Safety instructions regarding troubleshooting.....	69
9.1.1	Behaviour in the event of failures .....	70
9.1.2	Troubleshooting.....	71
9.1.3	Starting up again after a hazardous fault .....	71
9.2	Failure log .....	72



# Content

---

<b>10</b>	<b>Maintenance</b> .....	<b>73</b>
10.1	Safety instructions regarding maintenance .....	73
10.2	Maintenance schedule.....	75
10.3	Maintenance log.....	76
10.4	Maintenance works .....	78
10.4.1	Defrosting .....	78
10.4.1.1	Defrosting: Overview of typical process.....	78
10.4.1.2	Optimising the defrosting cycle .....	79
10.4.1.3	Defrosting: Hot gas defrosting.....	79
10.4.1.4	Defrosting: Typical values.....	80
10.4.1.5	Defrosting: Switching component heaters on and off .....	81
10.4.1.6	Activating defrosting function .....	81
10.4.2	Clean the machine .....	81
10.4.3	Replacing fans .....	82
10.4.4	Checking, retightening fastening elements .....	84
10.4.5	Inspection of drive, repair .....	85
10.4.6	Flap adjustment .....	85
10.5	Measures to be implemented upon completion of the maintenance .....	86
<b>11</b>	<b>Disassembly and disposal</b> .....	<b>87</b>
11.1	Safety instructions regarding disassembly and disposal.....	87
11.2	Disassembly .....	90
11.3	Disposal .....	90
<b>12</b>	<b>List of figures</b> .....	<b>91</b>
<b>13</b>	<b>List of tables</b> .....	<b>91</b>
<b>14</b>	<b>Index</b> .....	<b>92</b>





## Information on the operating instructions

# 1 Information on the operating instructions

## 1.1 General details

### Product classification

The product described in this document qualifies as a complete machine within the context of Directive 2006/42/EC of the European Parliament and the Council from 17 May 2006 regarding machines and changes to the Directive 95/16/EC (EC machine directive).

Corresponding with this classification, the term "machine" is used for product-related specifications and statements in this document.

### Product

Description	Specification
Machine name	GIK (Güntner insulated cooler)
Type	GIKN, GIKS
Design features	Air cooling unit for industrial cooling of cool areas, comprising a refrigerant evaporator with fin coil, fans, defrosting devices, compact installation in a thermally-insulated housing that is separated from the cool area completely for defrosting and maintenance purposes.
Machine number (device number) *	
Year of construction *	

Tab. 2: GIK product specifications

\* To be filled in by the manufacturer

### Manufacturer and person responsible for compiling the technical documentation in accordance with the EC Machinery Directive 2006/42/EC

Description	Specification
Company	Güntner GmbH & Co. KG
Street, No.	Hans-Güntner-Str. 2 - 6
Post code, Town	D-82256 Fürstenfeldbruck
Phone	+49 8141 242-0
Fax	+49 8141 242-155

Tab. 3: Details on the manufacturer and people responsible for documentation

## 1.2 Using the operating instructions

The operating instructions contain important notes for handling the system in a safe and efficient manner. They are part of the system and must be stored in close proximity to the system in a way that they can be accessed by the personnel working on the system at any time.

The prerequisite for safely implementing works on the system is the compliance with all specified safety instructions and instructions. Therefore, the personnel must have carefully read and understood these operating instructions before starting any works.

Furthermore, the local regulations on the prevention of accidents and the general safety regulations applicable at the installation location of the system must be observed.

Figures in these instructions are intended for basic understanding and may deviate from the actual design of the system. No claims may be derived on the basis of the aforementioned.

## 1.3 Symbols, abbreviations, terms

Within the framework of this document, symbols, abbreviations, and terms with the following meaning are used:

→	See also
►	Enumeration
–	Enumeration
1	Item number
1.	Action step
OIs	Operating instructions
Oh	Operating hours
SP	Specialist personnel with special knowledge and skills
incl.	including, included
min.	minimal, minimum
max.	maximal, maximum
Machine	Specifications, information and instructions relating to the product
MD	Directive 2006/42/EC of the European Parliament and the Council of 17 May 2006 on machinery, and amending Directive 95/16/EC – Machinery Directive –
Item	Item number
PPE	Personal protective equipment
perm.	permissible (permissible value)
☒	Applicable
☐	Not applicable
<i>Text in italics</i>	Explanations on subject matters



## Information on the operating instructions

---

NH <sub>3</sub>	Ammonia coolant
Vol-%	Volume percentage (concentration specification based on a volume)
ppm	parts per million Concentration specification, stands for the millionth part
Dt	Delta t; temperature difference
EN 378	European Standard 378: Refrigerating Systems & Heat Pumps-Safety & Environmental Requirements
EN	European Standard
DIN	German Standard
ISO	International Standard
VDE	German Association for Electrical, Electronic & Information Technologies
TCC	Technical connection conditions
ESC	Electricity supply company
VDI	Association of German Engineers

## 1.4 Symbol definition

### Warnings and safety instructions

Warnings and safety instructions in the manual are highlighted by pictograms and are placed on a colour background.

Warnings and safety instructions identifying basic dangers are additionally initiated with signal words expressing the extent of damages. These are structured as follows:

 **SIGNAL WORD****Cause of the danger!**

- **Behavioural instructions to avoid the danger.**

**Consequences when not observing the danger.**

Warnings and safety instructions embedded in the individual action steps that describe an immediately existing danger or cause of material damage with a direct relation to the activity are structured as follows:

 **SIGNAL WORD****Cause of the danger!**

- **Behavioural instructions to avoid the danger.**

**Consequences when not observing the danger.**

- ▶ All warnings and safety instructions must be observed absolutely!
- ▶ Always act prudently during any works in order to avoid accidents and personal and material damages!

The colour backgrounds and colour pictograms in connection with the signal words have the following meaning:

 **DANGER**

... indicates an immediate danger that will result in death or severe injuries if it is not avoided.

 **WARNING**

... indicates a possibly dangerous situation that may result in death or severe injuries if it is not avoided.

 **CAUTION**

... indicates a possibly dangerous situation that may result in minor injuries if it is not avoided.

**NOTICE**

... indicates a possibly dangerous situation that may result in material damages if it is not avoided.

### Tips and recommendations

 ... indicates tips and recommendations, as well as information for efficient and trouble-free operation.

## Information on the operating instructions

---

### Special safety instructions

In order to indicate special dangers, the following pictograms are used in connection with the safety instructions:



... indicates hazards due to electric current.

In case of non-compliance with the notes on safety, there is a risk of severe or fatal injuries.



... indicates hazards due to crushing.

If the safety instructions are not adhered to, there is a risk of hand injuries due to crushing between parts that operate close to each other, or due to catching, pulling in or other similar incidents.



... indicates hazards due to crushing when body parts are drawn in.

If the safety instructions are not adhered to, there is a risk of injuries due to being drawn in to moving parts.



... indicates hazards due to automatic restarting.

If the safety instructions are not adhered to, there is a risk of injuries due to a sudden restart.

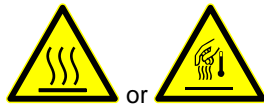

... indicates hazards due to hot surfaces.

If the safety instructions are not adhered to, there is a risk of burns and skin injuries due to heat.



... indicates hazards due to cold surfaces or fluids.

If the safety instructions are not adhered to, there is a risk of skin irritation and frostbite due to heat.



... indicates hazards due to poisonous substances.

If the safety instructions are not adhered to, there is a risk of long-lasting damage to health.



... indicates hazards due to corrosive substances.

If the safety instructions are not adhered to, there is a risk of long-lasting damage to health due to coming into contact with corrosive substances.



... indicates hazards due to harmful or irritating substances.

If the safety instructions are not adhered to, there is a risk of injuries with long-lasting damage to health, allergies or mucous membrane irritation due to coming into contact with hazardous substances.

## Information on the operating instructions

---



... indicates hazards due to hazardous substances at a high risk of fire and explosion.

If the safety instructions are not adhered to, there is a risk of injuries due to inflammation or due to flammable substances igniting.



... indicates hazards due to explosive substances in open or closed containers and lines.

If the safety instructions are not adhered to, there is a risk of injuries due to explosive substances, gases, vapours, mist or dusts igniting.



... indicates locations with a fall hazard.

If the instructions are not adhered to, there is a risk of severe injuries or death.



... indicates locations with a slip hazard.

If the instructions are not adhered to, there is a risk of severe injuries.



... indicates locations with a trip hazard.

If the instructions are not adhered to, there is a risk of severe injuries.

### Special prohibitions



... indicates hazards due to fire, sparks, heat, smoke, embers or hot items in areas at a high risk of fire and explosion.

If the safety instructions are not adhered to, there is a risk of severe injuries or even death due to inflammation or due to flammable substances igniting.



## Information on the operating instructions

---

### Special instructions



Use eye protection!

Eye protection: Use a protective mask, protective goggles or a face mask.



Use hand protection!



Use respiratory protection!



Use protective clothing!



Release before working!



## Information on the operating instructions

---

### 1.5 Limitation of liability

All information and notes in these instructions have been compiled taking into consideration applicable standards and regulations, the state of the art, as well as our long-term findings and experiences.

The manufacturer shall not assume any liability for damages resulting from:

- ▶ Non-observance of the instructions
- ▶ Non-intended use
- ▶ Use of non-qualified and non-instructed personnel
- ▶ Unauthorised conversions
- ▶ Technical modifications
- ▶ Use of non-approved spare parts

With regard to special designs, when using additional order options, or on the basis of the latest technical changes, the actual scope of delivery may deviate from the explanations and representations given herein.

The obligations stipulated in the delivery agreement, the general terms and conditions of business, as well as the terms and conditions of delivery of the manufacturer, and the statutory regulations applicable at the time the agreement is concluded shall be applicable.

We reserve technical modifications within the framework of improving the performance characteristics and further development.

#### **Warranty**

The manufacturer guarantees the operativeness of the applied procedural technology and the specified performance parameters.

The warranty period shall begin with the flawless transfer.

#### **Wear parts**

The concept of wear parts comprises all parts in direct contact with the material to be processed within the framework of intended use.

These parts are not covered by the warranty and deficiency claims, insofar as these are operation-related wear marks.

#### **Lifetime guarantee**

Regarding wear parts, a lifetime guarantee covering a period of 6 months upon flawless acceptance is granted.

#### **Terms and conditions of guarantee**

The terms and conditions of guarantee can be found in the general terms and conditions of business of the manufacturer.



## Information on the operating instructions

---

### 1.6 Customer service

Our customer service is available for technical inquiries.

Information on the locally responsible contact person can be obtained via telephone and can be retrieved at any time via fax, email, or using the internet.

Furthermore, our employees are continuously interested in new information and experiences resulting from application that possibly are important for the process of improving our products.

### 1.7 Conformity declaration

The machine has been designed and manufactured in compliance with the basic safety and health requirements of the EC Machinery Directive including its revisions valid at the date of declaration.

The conformity declaration is part of the contract documents.

### 1.8 Copyright protection

This document is protected by copyrights.

Any unauthorised forwarding of these instructions to third parties, reproductions of any type and form, even in excerpts, as well as any use and/or disclosure of the contents without the written consent of the publisher shall be prohibited.

Contraventions will result in compensation. Further claims shall remain reserved.

## 2 Safety

This chapter provides an overview of important safety aspects for the protection of the personnel against possible risks and for safe and trouble-free operation.

If the specified instructions, warnings, and safety instructions are not observed, this may result in substantial dangers.

### 2.1 Use according to intended purpose

The machine is intended for commercial use and has been designed and manufactured exclusively for the following intended purpose:

The GIK (Güntner insulated cooler) is used for industrial air cooling of cool areas and enables the insulated cooler to be separated from the cool area automatically when defrosting.  
The device is supplied for a specific operating point.

#### **WARNING**

##### **Risk due to non-intended use!**

- **Basically, only use the machine as intended in accordance with the details in this document, particularly complying with the application limits specified in the technical data.**
- **Any use of the machine differing from or exceeding the intended use must be relinquished.**
- **Conversion, retrofitting, or modification of the design or of individual components with the objective of modifying the field of application or the applicability of the machine must be relinquished.**

**Any other use differing from the intended use of the filler system may result in hazardous situations.**

- ▶ Any claims filed on the basis of damages resulting from non-intended use shall be excluded.
- ▶ The operator shall assume the exclusive liability for any damages resulting from non-intended use.

### 2.2 Incorrect use

#### **WARNING**

##### **Risk of injuries due to incorrect use!!**

- **Refrain from all misuse on the machine.**
- **Only use the specified operating fluid!**
- **Do not exceed the maximum permissible operating pressure.**
- **Do not change the operating point.**
- **Do not change the fan's air output.**
- **Do not change the operating fluid flow.**
- **Never modify the device without consulting the manufacturer and obtaining their approval in writing.**

**Incorrectly using the machine can result in dangerous situations for personnel and serious property damages.**



## Safety

---

### 2.3 Responsibilities

#### 2.3.1 Responsibility of the operator

##### Operator

The operator is any natural person or legal entity using the machine or ceding it to third parties for application and who is responsible for the safety of the user, the personnel, or third parties during the use.

##### Obligations of the operator

The machine is used in the commercial field. Therefore, the machine operator is subject to the statutory obligations regarding industrial health and safety.

Along with the warnings and safety instructions in this manual, the safety regulations, accident prevention regulations, and environmental protection regulations applicable to the field of application of the machine must be complied with.

##### **The operator must particularly:**

- ▶ inform on the applicable industrial safety regulations.
- ▶ identify possible additional dangers resulting from the specific application conditions at the installation location of the machine by means of risk assessment.
- ▶ implement the required behavioural requirements for machine operation in operating instructions at the installation location.
- ▶ regularly check whether the operating instructions he developed correspond to the current state of the rulebooks during the entire application time of the machine.
- ▶ adapt the operating instructions to new regulations, standards, and application conditions, if required.
- ▶ manage the responsibilities for the processes of installing, operating, maintaining, and cleansing the machine in a clear and unambiguous manner.
- ▶ ensure that all employees working on the machine have read and understood the operating instructions. Furthermore, the operator must regularly train the personnel on how to handle the machine and must regularly inform the personnel on the possible dangers.
- ▶ provide the personnel commissioned with the implementation of works on the machine with the specified and recommended protective equipment and observe the consistent compliance with the obligation to wear it.
- ▶ ensure the required clearances and sufficient illumination for working safely, as well as constant order and cleanliness at the installation location of the machine and the environment.

Moreover, the operator is responsible that the machine

- ▶ constantly is in an immaculate condition from a technical point of view.
- ▶ is maintained in accordance with the specified maintenance intervals.
- ▶ all safeguards of the machine are checked for completeness and functionality on a regular basis.

### 2.3.2 Responsibility of the personnel

The machine is used commercially. Therefore, the personnel is subject to the statutory obligations in the field of industrial safety.

Along with the warnings and safety instructions in this manual, the safety regulations, accident prevention regulations, and environmental protection regulations applicable to the field of application must be complied with.

It is particularly important that the personnel:

- ▶ inform on the applicable industrial safety regulations.
- ▶ implement the behavioural requirements for machine operation specified in the operating instructions at the installation location.
- ▶ recognise the assigned competences for the processes of operating, maintaining, and cleansing the machine in a proper manner.
- ▶ must have read and understood the operating instructions completely before starting any works.
- ▶ wear the specified and recommended protective equipment.

Furthermore, within his scope of competence, any person implementing works on the machine is responsible that the machine

- ▶ constantly is in an immaculate condition from a technical point of view.
- ▶ is maintained in accordance with the specified maintenance intervals.
- ▶ all safeguards are checked for completeness and functionality on a regular basis.



## Safety

### 2.4 Personnel requirements

#### 2.4.1 Safety requirements

Any activities on the machine must only be implemented by persons who are able to implement their work in a proper and reliable manner and who correspond to the requirements specified in each case.

- ▶ Persons with impaired responsiveness, e.g. due to drugs, alcohol, or pharmaceuticals, must not implement any works.
- ▶ When deploying personnel, the age- and profession-specific regulations applicable at the installation location must be observed.

#### Qualification



#### Risk of injuries in the event of insufficient qualification!

- Any activities must only be implemented by persons disposing of the required training, the required knowledge, and the experience.

**An improper mode of working may result in substantial personal and material damages.**

#### 2.4.2 Qualification requirements

##### Instructed personnel

The term instructed personnel comprises persons who have been informed comprehensively and demonstrably by the operator regarding the tasks they are commissioned with and the possible risks.

##### Skilled personnel

The term skilled personnel comprises persons who, on the basis of their vocational training, know-how, and experiences, as well as knowledge of the relevant regulations, are able to implement the commissioned works properly, to self-dependently identify possible dangers, and to avoid personal or material damages.

##### Competent specialist personnel

Competent specialist personnel are people who have gained and proven particular experiences, knowledge and skills for the safe implementation of activities in specialised fields (e.g. qualified electricians, qualified hydraulic engineers, qualified pneumatic engineers) and meet the requirements referred to below:

##### Specialised electricians

Specialised electricians are persons who, on the basis of their vocational training, know-how, and experiences, as well as knowledge of the relevant regulations, are able to implement works on electrical systems properly, to self-dependently identify possible dangers, and to avoid personal and material damages caused by electrical current.

All works on the electrical equipment must be implemented by specialised electricians.

##### Personnel specialised in the field of hydraulics

Personnel specialised in the field of hydraulics are persons who, on the basis of their vocational training, know-how, and experiences, as well as knowledge of the relevant regulations, are able to implement works on hydraulic systems properly, to self-dependently identify possible dangers, and to avoid personal and material damages caused by hydraulics.

All works on the hydraulic equipment must be implemented by personnel specialised in the field of hydraulics.

### 2.4.3 User requirements

Each person performing activities on the machine is considered to be a user.

Depending on their activity, each user must meet the following qualification requirements:

**Qualification of users based on phase of life and task category**

Task	Personnel
Transport, installation	Specialist personnel
Assembly and installation tasks	Competent specialist personnel
First start-up	Competent specialist personnel
Operation	Trained personnel
Preventive maintenance	Competent specialist personnel
Fault rectification	Competent specialist personnel
Decommissioning	Competent specialist personnel
Disassembly, disposal	Competent specialist personnel

*Tab. 4: Qualification requirements for personnel*

### 2.4.4 Instruction

All persons commissioned with works must be instructed by the operator on the activities he/she is commissioned with and possible dangers during the works before starting any works.

- ▶ Repeat the instructions at regular intervals.
- ▶ Document each personnel instruction in a demonstrable manner.

Date	Name	Topic of instruction	instructed by	Signature of the person instructed

*Tab. 5: Sample for instruction protocol*

## Safety

### 2.4.5 Unauthorised persons

An unauthorised person is anyone who:

- ▶ has not, or not fully read this operating manual, or does not have a clear understanding of it
- ▶ does not meet the qualification requirements for working on the machine
- ▶ has not been briefed and/or authorised by the operator or their representative for their particular role



#### WARNING

#### Hazards for unauthorised persons!

- **Unauthorised persons may not carry out any operations on the machine.**
- **Maintenance tasks on the machine may only be carried out by qualified, authorised persons.**

**Unauthorised persons are not familiar with the hazards present in the working area, and may suffer serious injury or cause injury to others or significant damage to property.**

### 2.5 Personal protective equipment

It is necessary to wear personal protective equipment during any works, in order to minimise health hazards. Therefore:

- ▶ Before starting any works, properly apply the protective equipment and wear the equipment mentioned in each case during any works.
- ▶ Additionally, the signs containing pictograms on the personal protective equipment attached in the working area must absolutely be observed.

#### Wear basically

Wear basically during any works.



#### Protective work clothing

Closely fitting work clothing with low tear-resistance, tight sleeves and without protruding parts; mainly to protect against being caught by moving machine parts.

Do not wear rings, chains or other jewellery.



#### Sturdy protective gloves

To protect the hands against abrasion, grazing, scratches, cuts, punctures or other hand injuries and against mild burns when touching hot surfaces.



#### Protective gloves, chemical-resistant, thermo-insulated

To protect the hands against contact with corrosive or harmful substances and when touching hot or cold surfaces.



#### Safety shoes

To protect the feet against injuries caused by falling parts and against slipping and falling on slippery surfaces.

**Specific work requirements**

Some work requires the use of special protective equipment. Safety notes are given in the respective sections of this manual.

**Protective goggles with side protection**

To protect the eyes against contact with hazardous substances, splashes of fluid or compressed air.

**Safety vest**

Or wear reflective clothing to increase visibility to others. Wear the safety vest or reflective clothing in particular:

- ▶ when working in public places
- ▶ when working more than 1 m above floor height

Safety vests and reflective clothing must be cleaned properly to maintain visibility.

**Safety harness**

To protect against falling if there is a high risk of falling.

- ▶ There is a high risk of falling if there are certain height differences and if the working area is unsecured due to missing railings.
- ▶ Always put the safety harness on in such a way that the safety rope is connected to the safety harness and a fixed attachment point; provide an impact absorber if necessary.
- ▶ Safety harnesses may only be used by people who are trained especially for this.

**Industrial safety helmet**

To protect against head injuries due to falling or flying parts or materials.

## Safety

### 2.6 Dangers

The machine has been subject to a risk assessment. The dangers determined within the framework of the aforementioned have been eliminated, as far as possible, and identified risks have been reduced. However, the machine entails residual risks that are described in the following section.

- ▶ The warnings and safety instructions specified here and in the action chapters of this manual must be absolutely observed in order to avoid possible damages to the health and hazardous situations.

#### 2.6.1 Risks due to mechanic dangers

##### Moving components

 **WARNING**



##### Risk of injury due to moving parts!

- Persons are prohibited from staying in the danger area or in the immediate area.
- Do not remove covers such as flaps, doors, hatches and service covers.
- Do not deactivate, render inoperative, or override safety equipment and/or functions.
- Never reach into running equipment.
- Prior to accessing the danger area, switch off the power supply and secure the machine against reactivation.
- Prior to working in dangerous areas, always wait until running parts have stopped and residual energy has dissipated

**Motorised moving modules and parts may cause severe injuries!**

##### Fan with imbalance

 **WARNING**



##### Hazard due to ejected rotating components if there is an imbalance

- Check the fan regularly to ensure that it is free of contamination, frost, icing and defects; rectify any problems immediately
- Check that the fans are running smoothly
- Check that vibration-reducing equipment is present and working

**Vibrations and ejected parts caused by an imbalance can cause severe injuries and damage to property.**

 **WARNING****Danger of falling!**

- When carrying out any tasks on and in a machine that is suspended from the ceiling, close the defrosting flaps and secure to prevent inadvertent opening.
- While working at a great height, use a stable ladder or working platform with railings.
- Secure persons, tools, equipment, replacement parts, and loose objects at height against falling.
- Secure the area against access by unauthorised persons.
- In the work area, always attach and wear personal protective equipment against falling.

When working on objects at height, unsecured persons may fall or be injured by falling objects.

## Safety

---

### Crushing parts between closely operating components

 **CAUTION**



#### Crushing hazard!

- Do not reach into gaps between closely operating components while working.
- Complete the work with special care and attention.
- Wear sturdy gloves when working.

During service and repair work on components, fingers may be trapped by closely operating components!

### Sharp edges and pointed corners

 **CAUTION**

#### Risk of injuries due to edges and corners!

- When implementing works near sharp edges and pointed corners always be careful.
- Wear protective gloves

Sharp edges and pointed corners may result in abrasive burns, scratches, and cuts.

### Smooth surfaces

 **CAUTION**

#### Risk of injury due to smooth surfaces!

- Always wear safety boots in the working area.
- Complete the work with special care and attention.

People can slip on smooth surfaces.

### Contamination, scattered objects

 **CAUTION**

#### Risk of tripping due to contamination and scattered objects!

- Always keep the working area clean.
- Remove tools and objects no longer required.
- Identify trip hazards by means of eye-catching yellow-black tape.

Contaminations and scattered objects are sources for slipping and tripping and may result in substantial injuries.

## 2.6.2 Risks due to electric dangers

### Electrical current

 **DANGER**



#### Danger to life due to electrical current!

- Before starting any works on the electrical system, de-energise the electrical system. Check for zero-potential!
- Before starting any maintenance, cleansing, and repair works, switch off the electrical power supply and protect it against restart.
- If the insulation is damaged, switch off the power supply immediately and arrange for repair works.
- Do not bypass fuses or put them out of operation.
- When replacing faulty fuses also observe the proper amperage specification.
- Keep wetness and moisture away from live parts.
- Any works on the electrical system must basically be implemented by specialised electricians.

Any contact with live parts will result in death. Damages to the insulation or individual components may be life-threatening.

### Electrical lines

 **DANGER**



#### Risk of fatal injuries due to electric shock!

- All connections must be fastened and free of corrosion.
- Lines must be secured at their connections with a cord grip.
- Only use cables according to their properties for the approved intended use.
- Always select ladder cross-sections in sufficient thickness according to the power drain.
- Ensure correct protective conductor terminal.
- Protect cables and lines against heat, oil, dust, and aggressive media.
- Install cables and lines free of tripping. Do not place them close to sharp edges or on sharp corners. Prevent abrasive areas, kinks, and crushing.
- During use, do not leave the cable rolled up on the roll, drum, or in loops.
- Do not carry devices and tools on cables!
- Never pull plugs out of the outlet by the cable.
- Inspect cables and plugs prior to use. Do not use in case of damage! Have repaired or restored immediately by electrical technicians!
- Always secure cables and lines under tension so that they do not represent a source of danger and cannot cause injuries or be damaged.

Line damage may cause dangerous electrical shock and result in death.

## Safety

### 2.6.3 Risks due to thermal dangers

#### Hot surfaces

 **CAUTION**



**Risk of burns due to hot surfaces!**

- Wear protective clothing and protective gloves when implementing any works near hot components.
- Before implementing any works, ensure that the components have cooled down to ambient temperature.

Contact with hot components may result in burns.

#### Hot operating fluids

 **CAUTION**



**Risk of burns due to hot operating fluids!**

- Prior to handling operating fluids, measure their temperature; if necessary, allow the operating fluid and the container to cool to below 50 °C.

Operating fluids can reach high temperatures during operation and can cause burns if they come into contact with the skin.

#### Cold surfaces

 **CAUTION**



**Risk of frostbite due to cold surfaces!**

- Always wear protective work gear and protective gloves when working near cold components.
- Make sure that the components have heated up to ambient temperature before commencing any work.

Contact with cold components may cause frostbite.

#### Cold operating fluids

 **CAUTION**



**Risk of frostbite due to cold operating fluids!**

- Prior to handling operating fluids, measure their temperature; if necessary, allow the operating fluid and the container to warm to above 5 °C.

Operating fluids can reach low temperatures during operation and can cause frostbite if they come into contact with the skin.

## 2.6.4 Hazards due to vibration

### Vibrations



### **WARNING**

#### **Long-term damage due to strong vibrations!**

- Never disable the vibration damper.
- Do not remain on, in or in the vicinity of dangerous areas that are vibrating heavily during operation.
- Rectify imbalances on fans when carrying out maintenance.

**Strong vibrations can cause damage to health.**

## Safety

### 2.6.5 Risks due to materials and substances

NH3 coolant

► R717: NH<sub>3</sub> (ammonia)



#### Risk of poisoning

- Before carrying out any tasks where there is a risk of coolant leaking, read the safety data sheet of the coolant used and keep it to hand, in particular to ensure that the correct measures are taken if accidents occur.
- When carrying out any tasks where there is a risk of coolant leaking, use respiratory protection and keep self-contained breathing apparatus to hand.
- Install sensors and an alarm system for leaking coolant in the danger area
- Prevent coolant leaking by taking extreme care when working on and in the vicinity of components that conduct coolant
- If coolant leaks, warn all other persons present, leave the danger area and press the emergency stop switch. Take urgent measures to prevent further coolant leaks.
- Always air work spaces and areas well
- Tasks in narrow spaces must be monitored by a supervisor in visual range but outside the danger area.

Ammonia is a corrosive, poisonous irritant gas. As of an ammonia concentration of 0.2 % in the ambient air or if a person remains in ambient air that contains ammonia for an extended period of time, ammonia can be life-threatening or fatal.



#### Risk of explosion, fire and reaction!

- Prevent coolant leaking by taking extreme care when working on and in the vicinity of components that conduct coolant
- If coolant leaks, warn all other persons present, leave the danger area and press the emergency stop switch. Take urgent measures to prevent further coolant leaks.
- Always air work spaces and areas well
- Prevent water and liquid ammonia coming into contact with each other:  
Do not sprinkle any water on liquid ammonia.  
Do not use any water in machine rooms, in order to bond vaporous ammonia.  
Prevent ammonia water (aqueous ammonia) entering sewers and waters.

Explosion and fire can cause severe personal injury and significant damage to property.

**CAUTION****Risk of frostbite and skin irritation**

- Observe the manufacturer's safety data sheet.
- Avoid leaks, spilling and vapour formation.
- When working, wear protective rubber gloves, protective work gear and protective goggles with side protection.
- Do not eat, drink or smoke when working.

Coolants can cause frostbite and skin irritation if they come into contact with skin or eyes.

**How to respond in an emergency:****Always ensure that you are not putting yourself or others in danger!**

Allow experienced, trained personnel who are wearing the prescribed protective clothing to take any preventive and other measures:

- ▶ Use respiratory protection
- ▶ Use self-contained breathing apparatus when carrying out maintenance tasks in spaces with a high concentration of ammonia in the air.
- ▶ Ensure that the installation room is well aired.
- ▶ Safely dissipate any coolant vapour and coolant fluid that have escaped.

**Instructions if there are injuries:**

- ▶ Notify an emergency doctor immediately.
- ▶ Put on respiratory protection, protective gloves and protective clothing for your own safety.
- ▶ Put respiratory protection on the casualty and keep it on to prevent them breathing in vapours from saturated clothes.
- ▶ Inhalation:  
If the casualty has inhaled the vapour, bring them into the fresh air with the aid of self-contained breathing apparatus. Keep warm and calm. Consult a doctor. If they stop breathing, perform artificial respiration.
- ▶ Eye contact:  
Rinse the eyes with water for at least 15 minutes.  
Call for a doctor immediately.
- ▶ Contact with skin and clothing:  
Shower the casualty in tepid water if possible. Remove the wet clothing carefully after a few minutes. Rinse the wet body parts with water for at least 15 minutes. Call for a doctor immediately.
- ▶ Swallowing  
Swallowing is not considered a possible means of exposure.



## Safety

---

### 2.6.6 Risks due to neglected ergonomic principles

#### Unhealthy posture, special efforts



#### Damage to health due to unhealthy posture!

- Have heavy components always lifted by more than one person.
- Carry out work on low-mounted components always in squatting position, not stooping.
- When kneeling, use knee protection; when sitting, use seat cushion.
- For any work on high-mounted components, work in an upright, straight posture.
- For all work, use technically perfect tools suitable for carrying out the work safely.

Lifting heavy components incorrectly and an unnatural posture when working might cause health problems.

### 2.6.7 Hazards due to operation environment

#### Illegible labelling



#### Risk of injuries due to illegible symbols!

- Pictograms, safety instructions, warnings, and operating instructions must be kept in a well legible condition at all times.
- Damaged or blurred pictograms, labels, signs, or stickers must be replaced immediately.

Stickers and labels that have become illegible do no longer sufficiently identify dangerous spots and are not able to indicate the possible risks of injuries.

## 2.7 Hazardous substances

### NH<sub>3</sub> (ammonia) coolant

Type of hazard	→ Safety data sheet (SDB)
Poisoning, asphyxiation, freezing, acid burns, burns. Loss of consciousness and inability to move. Corrosive if it comes into contact with the skin or eyes. Forms an explosive gas mixture at high pressures and if there is a high concentration of air.	Observe the manufacturer's SDB for the operating fluid that is used

Tab. 6: NH<sub>3</sub> (ammonia) coolant, hazards according to the safety data sheet

### Hydraulic oil, lubricants, motor oil, gear oil

Nature of the hazard	→ Safety data sheet (SDS)
Harmful to health in the event of skin and eye contact, toxic when inhaling spray mists and when swallowing the liquid splashes or droplets of grease; Hazardous to the environment.	Observe the manufacturer SDS of the op. materials used, e.g.: Motor oil; SDS 455028-DE01, vers. 1 of 04.08.2004

Tab. 7: Oils and greases, hazards acc. to safety data sheet

### Cleaning agents/solvents

Nature of the hazard	→ Safety data sheet (SDS)
Risk of swallowing, inhalation and skin irritations. Hazardous to the environment. Acetone: Risk of the generation of an explosive mixture with air.	Observe the manufacturer SDS of the op. materials used

Tab. 8: Cleaning agents/solvents, hazards due to cleaners, solvents



## Safety

---

### 2.8 Environmental protection

#### **NOTICE**

Severe environmental damage is caused by NH<sub>3</sub> (ammonia) leaking!

- Safely prevent coolants leaking.
- Prevent damage to all components that conduct coolant.
- Before opening the coolant lines, have a specialist company extract the coolant safely and completely by suction.

NH<sub>3</sub> (ammonia) that leaks causes severe damage to the environment.

#### **NOTICE**

Damages to the environment due to improper handling of hazardous substances!

- Carefully remove escaping, used, or excessive lubricant.
- Collect replaced oil in suitable containers.
- Handle paint residue, solvents, and cleaners in accordance with the safety datasheet of the manufacturer.

Basically, dispose of all hazardous substances according to the local regulations and commission a specialised company, if required.

Improper or negligent use of hazardous substances may result in severe pollutions of the environment.

## 2.9 Fire and explosion protection

The following measures reduce possible fire and explosion risks. Therefore, all persons working in the danger area must observe compliance with the aforementioned at all times:

- ▶ Always keep the working areas clean. Remove residual materials, waste materials, dirt, empty containers, oil-containing and other inflammable cloths, etc. upon completion of the works.
- ▶ Do not store any empty or filled packagings, as well as loose materials in gaps or at parts and components.
- ▶ Immediately eliminate leakages at closed housings, devices, channels, lines, and filters.
- ▶ Keep away dust and dirt accumulations from motors, components getting hot, and components.
- ▶ Cleanse the material separators constantly.
- ▶ Check all bearings for correct operating temperature at short intervals suitable for the loads.
- ▶ Check electrical installation of parts and components, as well as required additional devices, such as inspection lamps or extension cords, for immaculate condition on a regular basis. Have faulty installations and devices immediately repaired by specialised electricians or replace them.

### **Welding work**

- ▶ Always carry out any repair work on components requiring welding or soldering work in specially equipped welding workshops applying particular safety measures and complying with the local safety regulations.
- ▶ For any welding and soldering work on fixed components in production or storage rooms:
  - stop production; shut down the transport equipment.
  - designate responsible supervisor.
  - cover immediate environment with wet special tarpaulins.
  - protect potential sources of fire such as narrow gaps, cracks in walls, breakthroughs or layers of dust against squirting welding beads.
  - monitor the welding station and its environment for at least 10 hours after the work has been completed.

## Safety

### 2.10 Safety installations

#### **WARNING**

**Danger to life due to faulty or bypassed safety installations!!**

- Before starting any works, always check that all safety installations are installed properly and functional.
- Never override any safety installations.
- Ensure that the safety installations are freely accessible at all times.

**Non-functional, bypassed, or overridden safety installations do not provide any protection against the dangers and may result in severe injuries and death.**

#### Locking the disconnection switch for fans

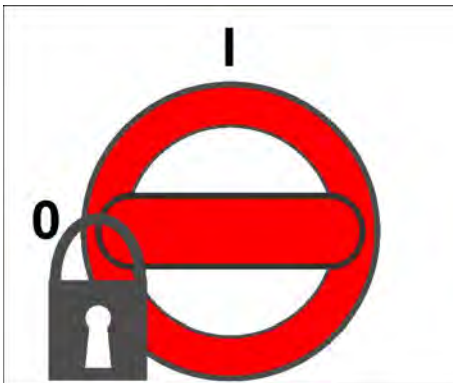

Fig. 1: Disconnection switch for fans, OFF ("0") position, secured with padlock

The disconnection switch for fans can be locked into the OFF ("0") position using a padlock to prevent unauthorised reactivation.

#### **WARNING**

**Risk to life due to unauthorised reactivation!**

- Prior to removing the lock, ensure that there is nobody in the danger zone.
- Prior to activation, ensure that all safety equipment is correctly installed and functional.
- Never remove a padlock without authorisation.

**Unauthorised reactivation can cause life-threatening injuries to people in the danger zone.**

#### Partial shutdown

#### **DANGER**



**Risk of fatal injuries due to power not being switched off completely.**

- Even if the disconnection switch for the fans is switched off, only touch other electrical components if the external power supply has already been switched off completely, you have checked that the system is de-energised and it has been secured to prevent reactivation.

**The disconnection switch for the fans in the terminal box only de-energises the fans and not any other electrical components.**

## 2.11 Protection against restart

 **WARNING**
**Risk of injuries due to unauthorised restart!**

- Please always observe the notes regarding the protection against restart in the instructions of this manual.
- Before starting any works on components, assemblies, or individual parts, always observe the procedure for the protection against restart described in the following.

When implementing works on components, assemblies, or individual parts, the persons at the danger spots may be injured when the energy supply is switched on.

 **DANGER!**
**Danger to life!**

In the machine,  
work is carried out.

**Do not switch on the  
machine!**

The machine may only be  
switched on by

.....



Fig. 2: Example for a warning sign when securing the machine against being switched on again

**Establish a safeguard of the machine against being switched on again:**

1. Shut down the machine.
2. Switch main switch to "0" ("OFF") and lock it using a padlock. Store the key safely and protect against any incompetent and unauthorised access.
3. Fasten a warning sign on the control unit and enter the name of the person in charge who is authorised to switch on the machine again on the warning sign (→ Fig. 2).

**Undo the safeguard of the machine against being switched on again:**

1. Check that all safety devices of the machine are installed properly, are in technically perfect condition and function properly.

 **WARNING**
**Risk of injury due to defective safety devices!**

- If the safety devices are defective, do not switch on the machine.
- Immediately report any detected defects to the person in charge.
- Arrange for repair by specialist personnel.

2. Make sure that there are no people in hazard areas and in the danger zone of the machine.
3. Remove the warning sign.
4. Unlock the main switch.



## Safety

---

### 2.12 Spare parts, usage and purchase

#### **WARNING**

##### **Risk of injury due to wrong spare parts!**

**Defective spare parts might impair the safety and cause damage, malfunctions through to complete failure.**

- **In general, only use original spare parts.**
- **Always purchase original spare parts from authorised dealers or directly from the manufacturer.**

Original spare parts can be purchased from authorised dealers or directly from the manufacturer (→ page 2).



Prior to any installation of spare parts, always read the enclosed operating or assembly instructions first and observe the information and notes contained therein on how to use the spare parts correctly.

### 2.13 Behaviour in case of hazards and accidents

#### **Preventive measures**

- ▶ Always be prepared for accidents and fire.
- ▶ Keep first aid equipment (first-aid kit, blankets, etc.) and fire extinguishers within reach.
- ▶ Familiarise personnel with the accident reporting, first-aid and rescue devices.
- ▶ Keep the access roads clear for the emergency vehicles.

#### **Proper conduct in case of emergency**

- ▶ Switch the device off at the main switch immediately.
- ▶ Remove affected persons from the danger zone.
- ▶ Initiate first-aid measures.
- ▶ Notify the person responsible at the emergency site.
- ▶ Alert the physician and/or the fire brigade if there are severe injuries.
- ▶ Keep the access roads clear as escape routes.

## 2.14 Signage

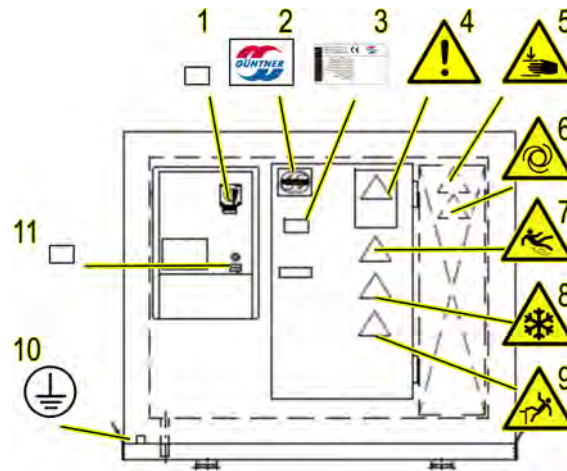

Fig. 3: Side signage: GIK with directly driven radial fans

- |   |   |    |                                       |
|---|---|----|---------------------------------------|
| 1 | "Fan repair switch" sign                      | 9  | Warning of fall hazard                |
| 2 | "Güntner" logo                                | 10 | "Earth connection" symbol             |
| 3 | Rating plate                                  | 11 | "Internal lighting light switch" sign |
| 4 | Warning of dangerous area                     |    |                                       |
| 5 | Warning of hand injuries                      |    |                                       |
| 6 | Warning of automatic start-up                 |    |                                       |
| 7 | Warning of slip hazard                        |    |                                       |
| 8 | Warning of cold surfaces and operating fluids |    |                                       |

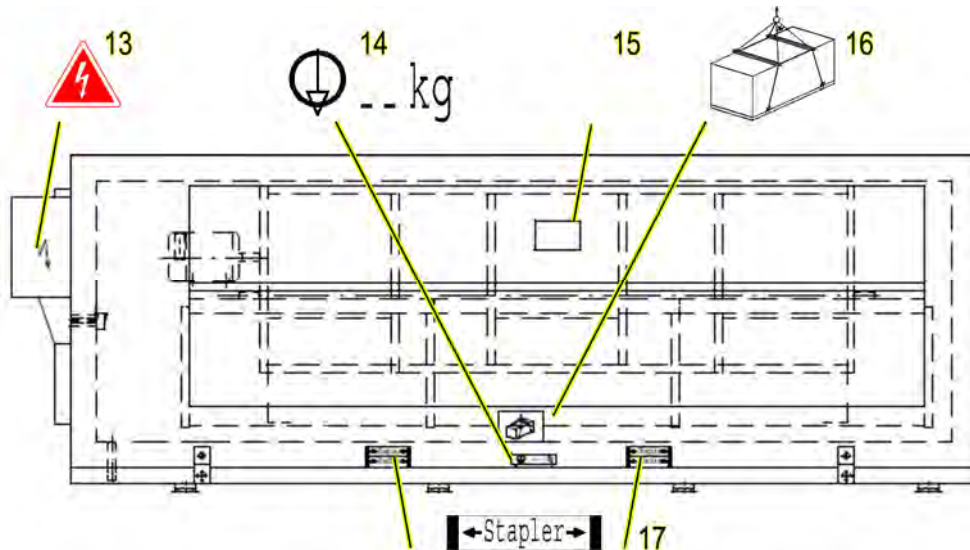

Fig. 4: GIK front signage

- |    |  |    |                 |
|----|--|----|-----------------|
| 12 | Warning of hazardous electrical voltage  | 15 | Crane transport |
| 13 | "Centre of gravity" sign   | 16 | Forklift insert |
| 14 | "Observe flap's pivoting range when attaching ducts!<br>Flap may only be moved electrically!" sign |    |                 |



## Safety

---

### Illegible labelling



#### **Risk of injuries due to illegible symbols!**

- Pictograms, safety instructions, warnings, and operating instructions must be kept in a well legible condition at all times.
- Damaged or blurred pictograms, labels, signs, or stickers must be replaced immediately.

**Stickers and labels that have become illegible do no longer sufficiently identify dangerous spots and are not able to indicate the possible risks of injuries.**

### 3 Technical data

#### 3.1 Entire machine

##### 3.1.1 Rating plate



Fig. 5: Rating plate

The rating plate contains the following information (from top to bottom):

- ▶ Manufacturer, CE mark, manufacturer's logo
- ▶ Project number
- ▶ Machine name (device name)
- ▶ Year of manufacture
- ▶ Maximum/minimum pressure
- ▶ Maximum/minimum temperature
- ▶ Test pressure
- ▶ Test date
- ▶ Test medium
- ▶ Volume

##### 3.1.2 Type key for machine name (device name)

###### Type key

The following information is contained in type key for the machine name (device name):

		Cooling block material	Diameter of core pipes [mm]	Pipe interval [mm]	
<b>GIK</b>	<b>S</b>	Galvanised steel	22 x 1.2	60 x 60	
	<b>N</b>	(See setup diagram)	15	50 x 50	

Tab. 9: Type key for machine name (device name) GIK...

##### 3.1.3 Dimensions and weights

→ Specifications in machine data sheet (appendix).



## Technical data

---

### 3.2 Evaporator

#### 3.2.1 Evaporator - General information

→ See appendix

#### 3.2.2 Evaporator - Construction data

→ See appendix

### 3.3 Installation conditions

#### Requirements for installation conditions and installation location

The following requirements for installation conditions and installation location must be met:

- ▶ All requirements that result from the operating conditions (see operating conditions chapter)
- ▶ Sufficient structural stability and suitability of the ceiling (if suspended from the ceiling) and the floor in accordance with the weight of the insulated cooler
- ▶ Horizontal, level ceiling (if suspended from the ceiling) or horizontal, level floor (if installed on the floor)
- ▶ No obstructions to the inlet and outlet air flow
- ▶ Free space in accordance with the dimension data; no risk of damage due to internal transport processes
- ▶ Free space to replace the fan in front of the maintenance access
- ▶ Clear path to transport to the installation location
- ▶ Sufficient accessibility on all sides and sufficient lighting to be able to carry out tasks safely when installing, operating, maintaining, repairing and disassembling (applicable local regulations on workplace lighting), as well as adhering to applicable provisions regarding clearance zones and escape routes that must be kept clear
  - Locate the device in such a way that it can be monitored and checked from all sides at any time.
  - Ensure that there is sufficient space for maintenance.
  - Ensure that all parts that conduct fluids, all connections and lines, and all electrical connections and lines are accessible.
  - Ensure that the piping labels are visible.
- ▶ Drain connection for condensate
- ▶ Unobstructed connection options for coolant lines
- ▶ Electrical installation in accordance with the requirements in the "Technical data" chapter
- ▶ If the air temperature is below  $-40\text{ °C}$ : install an electrical fan heater.

### 3.4 Operating conditions

#### 3.4.1 Permissible ambient conditions

Permissible ambient conditions	
Air temperature	-40 °C to +35 °C
Relative air humidity, maximum	100 %

*Tab. 10: Permissible ambient conditions*

#### 3.4.2 Operating conditions relevant for monitoring Machine

Device operating conditions relevant for operation monitoring	
Device temperature	-100 °C to +35 °C
Coolant operating pressure	32 bar
Test pressure for coolant lines	35.6 bar

*Tab. 11: Operating conditions relevant for monitoring*

#### 3.4.3 Emissions

→ See appendix

#### 3.4.4 Time operating conditions

Time operating conditions	
Uninterrupted operation duration, max.	Suited for uninterrupted operation
Activation pause	Not required
Maintenance intervals, min.	500 oh
Service life, max.	15 years

*Tab. 12: Time operating conditions*

#### Service life

Designed for at least the specified service life; from observing the product, we have established that regular, proper maintenance by the operator and a general overhaul by the machine manufacturer after the designed service life has passed can result in a significantly longer service life.



## Technical data

---

### 3.5 Interfaces

Interface	Type	Location
Air intake and outlet for room cooling	Housing opening	Cool area
Drive voltage for fans	Connection terminals	Terminal box
Power supply for heaters	Connection terminals	Terminal box
Control signal for fans	Connection terminals	Terminal box
Drive voltage for flap actuators	Connection terminals	Terminal box
Position signal for flaps	Connection terminals	Terminal box
Signals for temperature sensors	Connection terminals	Terminal box
Control point for switching fans off	Disconnection switch	Terminal box
Feed and return connections for coolant line	Pipe connections	Inside the insulated cell

Tab. 13: GIK interfaces (fans with EC motors)

### 3.6 Electrical connection

#### 3.6.1 Requirements on the electricity supply

##### Electric energy

The electric power supply has to satisfy the following conditions:

- ▶ The data of the operator's network must comply with the connection values of the machine follow in compliance with the allowable tolerances in match the information:
  - Voltage
  - Output signal [V]
  - Current [A]
  - Phase Fuse [A]
  - Frequency [Hz]
- ▶ The network operator has the burden of operating the machine can withstand. In particular, do not lead to failure or to an over- or under-supply of the machine and to its control and voltage control loops- peaks (eg when switching on or off of large consumers in the carrier network or a switch to emergency power).

#### 3.6.2 Residual current protective devices

Residual current protective device	
Type	Sensitive to universal current (type B or B+)
Tripping threshold	300 mA
Tripping behaviour	Delayed tripping, super-resistant, characteristic K

Tab. 14: Residual current protective device: Requirements

If there is a discrepancy between these specifications and those in the electrical documentation in the appendices, contact the manufacturer.

#### 3.6.3 Electrical specifications for fans

→ See appendix

#### 3.6.4 Electrical and other specifications for flaps and drives

→ See appendix

## Structure and function

### 4 Structure and function

#### 4.1 Short description

##### Insulated cooler

- ▶ Air freezer in thermally-insulated housing with air intake and air outlet openings
- ▶ Automatic, electrical defrosting with electronic controller
- ▶ Electrically-driven flaps to hermetically seal the housing to ensure that there is the minimum thermal effect on the cool area during the regular defrosting processes
- ▶ Housing can be accessed via a door for maintenance purposes
- ▶ Fan device inside the housing
- ▶ Evaporator in the form of a heat exchanger block ("cooling block"); built from fin pipes
- ▶ Water collection pan and water outlet

#### 4.2 Function diagram

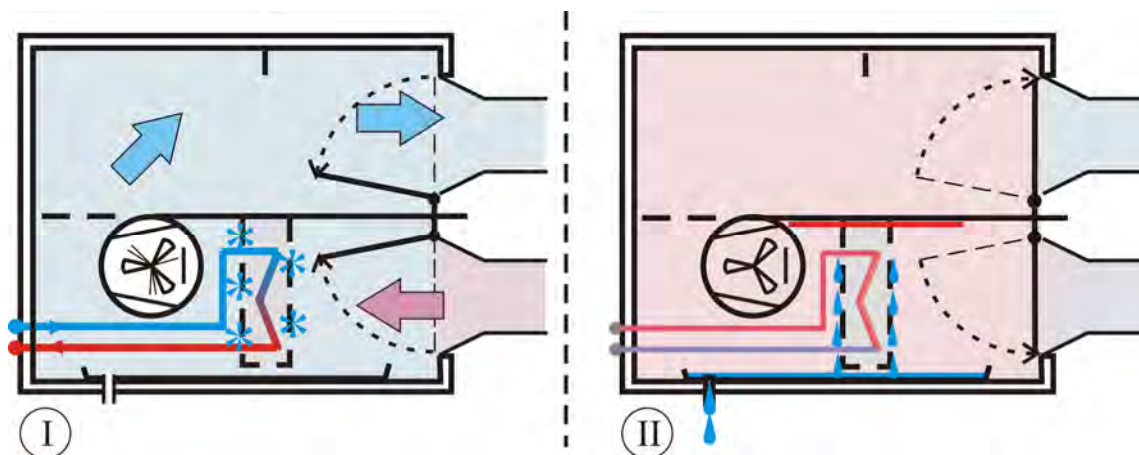

Fig. 6: Function diagram for GIK with radial fans (operation with air ducts)  
 (I – cooling, II – defrosting)

### 4.3 Exterior view

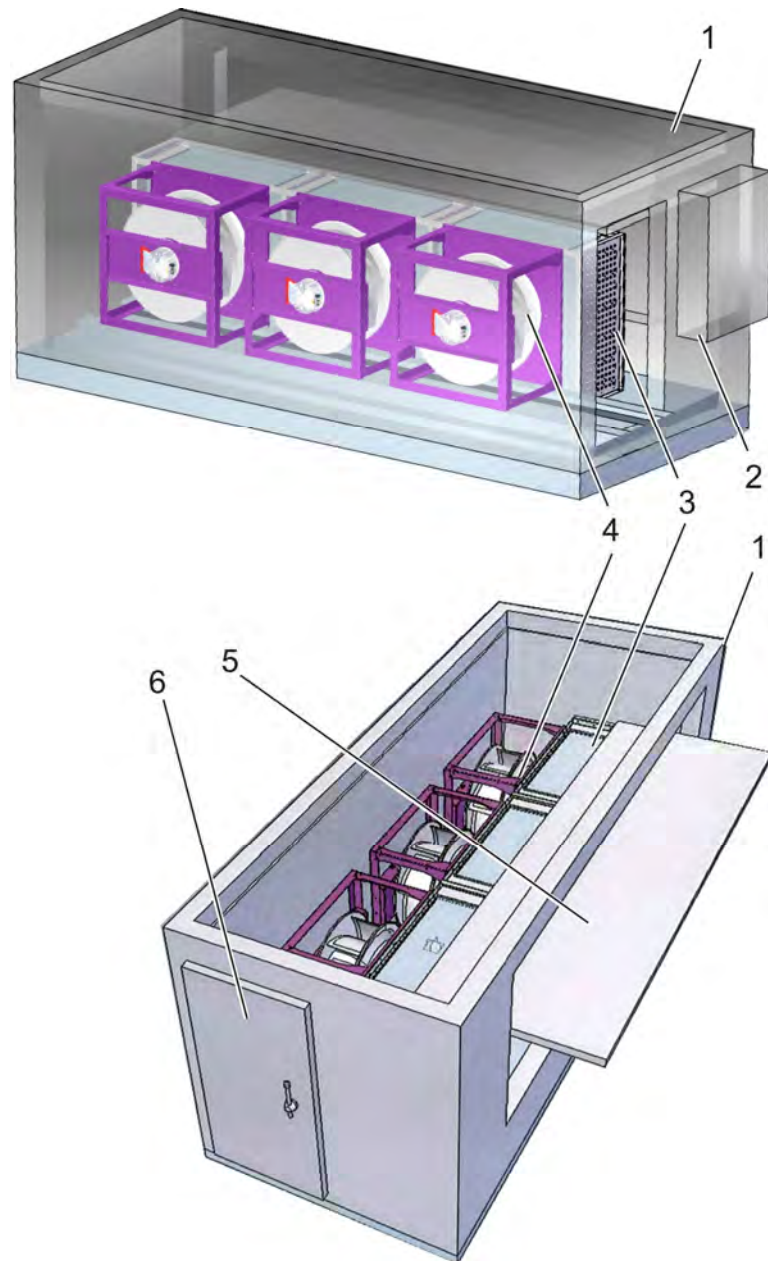

Fig. 7: Partially-transparent rear of GIK (version with radial fans - for operation with air ducts)

- |   |   |   |                               |
|---|---|---|-------------------------------|
| 1 | Insulated housing                         | 4 | Fans                          |
| 2 | Switching cabinet with operating elements | 5 | Flap for defrosting operation |
| 3 | Heat exchanger block                      | 6 | Maintenance door              |

## Structure and function

---

### 4.4 Overview of operating elements

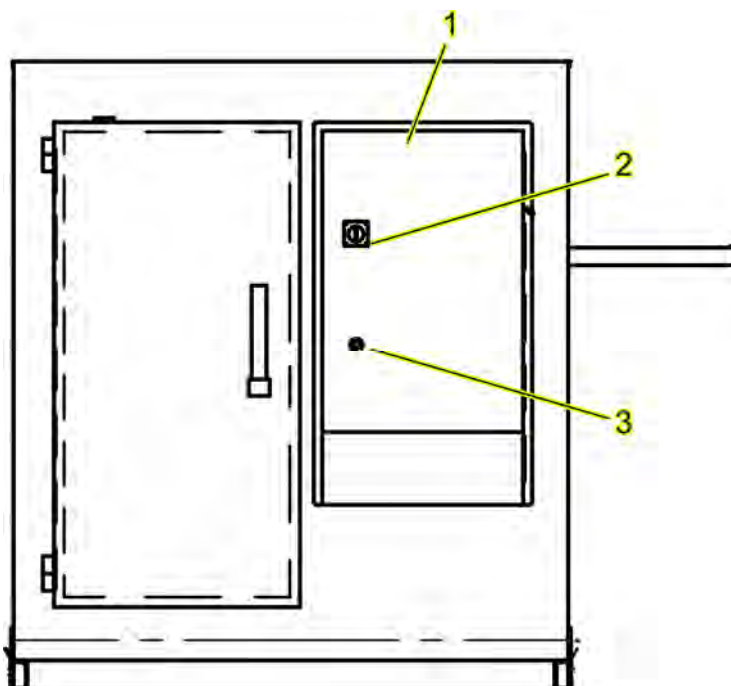



Fig. 8: GIK operating elements (example with door installed on the left)

- |   |                               |   |              |
|---|-------------------------------|---|--------------|
| 1 | Terminal box                  | 3 | Light sensor |
| 2 | Disconnection switch for fans |   |              |

## 5 Transportation

 Transportation, installation, and initial operation are only implemented by commissioned employees of the manufacturer or by personnel authorised by the manufacturer.

If required, operating and maintenance personnel of the operator may participate according to the instructions of these agents and observing the following notes.

### 5.1 Safety instructions regarding the transport



#### **WARNING**

**Danger to life due to falling load!**

- Never stay under suspended loads.
- Do not enter the swivel range of lifting gear during operation.
- Always wear a protective helmet when working with a crane.

Falling load or parts thereof may cause the death of people.



#### **WARNING**

**Risk of injuries due to swivelling transported goods!**

- Leave the swivel range of lifting gear before lifting any transported goods.
- Observe the transport instructions and the symbols on the transported goods.
- Always wear a protective helmet when working with a crane.

Transported goods where the centre of gravity is not in the middle may swivel strongly and may severely injure persons located nearby when lifted.

#### **NOTICE**

**Damages due to improper transportation!**

- Implement the loading and unloading processes and the intra-company transportation of goods with the utmost care.
- Observe the notes and symbols on the packaging.
- Always remove the transportation locks during installation only.

Improper transportation may result in significant damages to the transported goods and objects located nearby.

#### **Personnel**

- ▶ Transport works without using lifting gear or conveyors requiring monitoring may be implemented by instructed personnel.
- ▶ Transport works supported by lifting gear or conveyors requiring monitoring must only be implemented by instructed and authorised skilled personnel.

## Transportation

---

### Personal protective equipment

- ▶ During all transport works, wear basically:
  - Protective clothing
  - Protective gloves
  - Slip-resistant protective boots
- ▶ During all transport works with the help of lifting gear or ground conveyors, such as pulleys, cranes, fork-lift trucks, additionally wear
  - Industrial protective helmet

## 5.2 Transport inspection

Check the condition of the transported goods for completeness and damages immediately after having received the delivery.

In the event of externally visible transportation damages:

- ▶ Do not accept the delivery or accept the delivery under reservation only.
- ▶ Enter the extent of the damage into the transportation documents and into the shipping note of the forwarding agent as well.
- ▶ Initiate a complaint.

 Reclaim any deficiency immediately when receiving the transported goods. Claims for damages on the basis of transportation damages may only be asserted within the applicable complaint periods.

## 5.3 Transportation symbols

In accordance with the content, the outside of the transported goods is equipped with symbols that must be observed absolutely when transporting and storing the goods.

 If further transportation is designed for a later point in time, keep and re-use the original packaging.

- ▶ Original packagings must be kept at least until the warranty period has expired and must be kept ready for possible return shipments.
- ▶ Before ultimately disposing of the packagings, please document the type, the size, and the shape, including filling material, as well as the symbols attached to the transported goods.
- ▶ Either request original packagings from the manufacturer or create suitable transport containers according to the original packaging for later further transportation. The required symbols and labels must absolutely be re-attached clearly on the transported goods.

### Meaning of the transport symbols

The following transport symbols may be attached to the transported goods:



#### Top

The arrow heads indicate the top of the transported goods. They must point in an upwards direction, otherwise the content may be damaged.

**Fragile**

Identifies transported goods with fragile or sensitive content.

- ▶ Handle transported goods carefully, do not allow them to fall down, do not expose to impacts.

**Protect against moisture**

- ▶ Protect transported goods against moisture and keep dry.

## 5.4 Transporting and storing the machine

### 5.4.1 Storing the transported goods

#### Storage conditions

Only store the machine, components, modules, or parts under the following conditions:

- ▶ Do not store outdoors
- ▶ Store in a dry and dust-free location
- ▶ Do not expose to aggressive media
- ▶ Protect against sunlight
- ▶ Avoid mechanical vibrations
- ▶ Storage temperature: 5 to 45°C
- ▶ Relative humidity, max. 60%

When storing the machine for longer than 3 months, regularly check the general condition of all parts and the packaging. If necessary, refresh or renew the anti-corrosion protection.

If necessary, ensure you observe any additional or different storage information that may be located on the transported goods.

### 5.4.2 Handling the packaging

#### Handling the packaging

The goods being transported are safely packaged for the anticipated conditions, in an environmentally-friendly fashion. The packaging protects the components against damage and corrosion until the installation is started.

- ▶ Do not remove the packaging and transport locks until just before assembly.
- ▶ Dispose of the packaging material according to the applicable local regulations.

## NOTICE

#### Environmental damage due to incorrect disposal!

- Always dispose of packaging material in an environmentally-friendly manner.
- Observe local regulations and if necessary, commission a specialised company with the disposal.

**Packaging materials are valuable raw materials and can be reused or prepared and recycled.**

## Transportation

### 5.4.3 Transport on-site

#### 5.4.3.1 Remove the transported goods from the container

→ See appendix

#### 5.4.3.2 Use lifting equipment to transport the transported goods

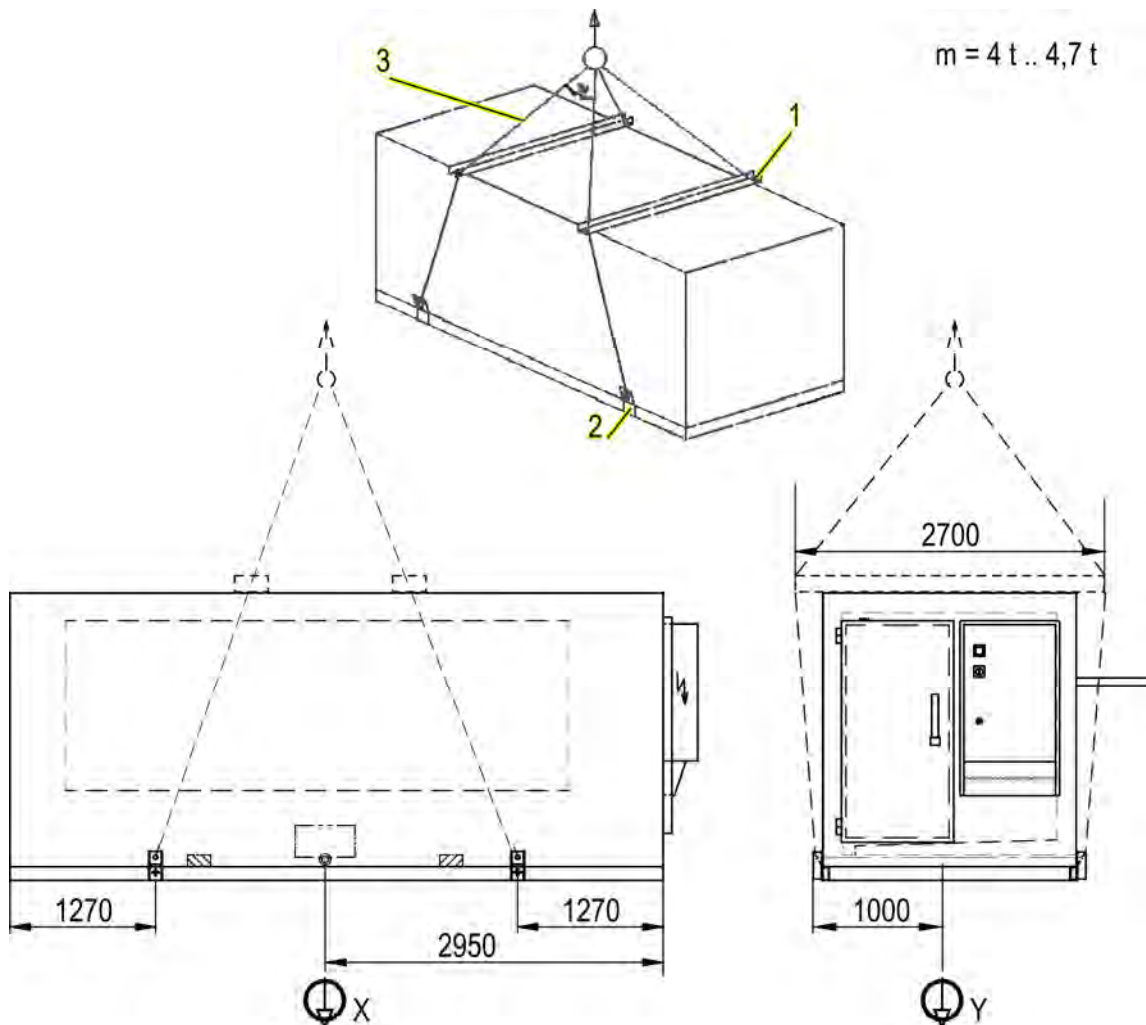

Fig. 9: Transporting using lifting equipment

The transported goods with marked attachment points can be directly transported with lifting equipment under the following conditions:

- ▶ The lifting equipment must be designed for the transport weight.
- ▶ The operator must be authorised to operate the lifting equipment.

1. Fit two strut brackets or bars (no. 1 in the illustration above).
2. Apply suitable transport shackles (no. 2).
3. Fasten the machine with ropes, belts or multiple-point suspension gear (no. 3).

4. Slowly lift the transported goods and check that the transported goods are suspended vertically. If necessary, adjust the position of the centre of gravity with the lifting equipment.
5. Move the transported goods to the destination.

#### 5.4.3.3 Use material handling equipment to transport the transported goods

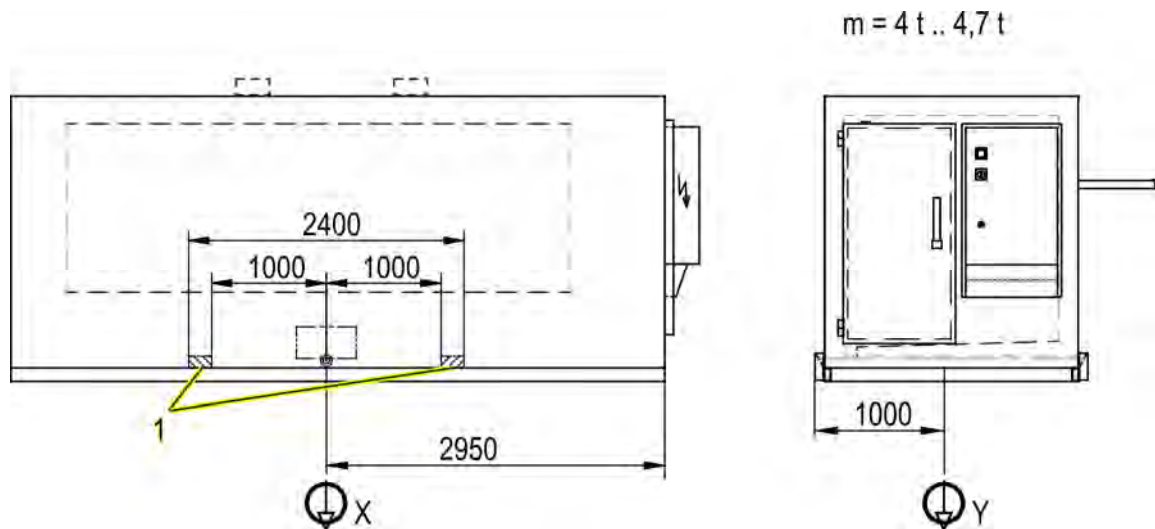

Fig. 10: Transporting using material handling equipment

Transport weight:	approx. 4.7 t
Minimum fork length	2400 mm
Fork width clearance	2000 mm

The cooling unit can be transported by material handling equipment, e.g. forklift, under the following conditions:

- ▶ The material handling equipment must be designed for the transport weight.
  - ▶ The operator must be authorised to operate the material handling equipment.
1. Drive the material handling equipment's forks into the designated points (no. 1 in the illustration above) until the forks protrude on the other side.
  2. Secure to ensure that the cooling unit and the material handling equipment cannot fall over. If necessary, adjust the position of the centre of gravity.
  3. Lift the cooling unit and transport it to the destination.

## Installation

### 6 Installation

#### **WARNING**

##### Risks due to incorrect installation and commissioning!

- Have all works in the fields of installation and initial operation exclusively implemented by employees of the manufacturer or by persons commissioned by him.
- Basically also commission the manufacturer with the required works in the event of later displacement, re-installation, and re-commissioning.
- Any unauthorised displacement, installation, and/or re-commissioning must be relinquished.

**Installation works and initial operation require trained skilled personnel with comprehensive experiences. Installation errors may result in life-endangering situations.**

After the installation, complete mounting, initial operation processes, and the implementation of the documented test runs by the manufacturer or by persons commissioned by the manufacturer have been completed, transfer to the operator takes place.

Afterwards, intended use by the operator is admissible, taking into consideration all details in these instructions.

#### Personnel

- ▶ Authorised specialist personnel with a driving licence for the lifting equipment

#### Personal protective equipment

- ▶ Protective overalls
- ▶ Protective helmet
- ▶ Protective gloves
- ▶ Safety boots

#### Work equipment

- ▶ Lifting equipment with sufficient load-bearing capacity
- ▶ Secure sling gear
- ▶ Assembly tool

#### **WARNING**



##### Escaping operating fluid poses a risk of poisoning, injury and burns

- Drain the operating fluid from the machine and the lines before carrying out any installation tasks
- Prevent loose connections; to do this:
- Affix the piping so that it is permanently free of vibrations and mechanical strains.
- Only have all installation and soldering tasks carried out by qualified specialist personnel
- Only use materials that are suitable for the pressures, temperatures and operating fluids that may occur

**Escaping operating fluid can cause severe bodily injuries due to poisoning and chemical burns.**

**WARNING****Danger of falling!**

- When carrying out any tasks on and in a machine that is suspended from the ceiling, close the defrosting flaps and secure to prevent inadvertent opening.
- While working at a great height, use a stable ladder or working platform with railings.
- Secure persons, tools, equipment, replacement parts, and loose objects at height against falling.
- Secure the area against access by unauthorised persons.
- In the work area, always attach and wear personal protective equipment against falling.

When working on objects at height, unsecured persons may fall or be injured by falling objects.

**WARNING****Hazard due to ejected rotating components if there is an imbalance**

- Check the fan regularly to ensure that it is free of contamination, frost, icing and defects; rectify any problems immediately
- Check that the fans are running smoothly
- Check that vibration-reducing equipment is present and working

Vibrations and ejected parts caused by an imbalance can cause severe injuries and damage to property.

**NOTICE****Ensure total cleanliness when carrying out installation and maintenance tasks.**

- Ensure total cleanliness when carrying out all maintenance and repair tasks, in particular those on components that conduct operating fluid.
- When installing for the first time: First bleed the system's transport pressure on the Schrader valve immediately before starting assembly.

Contamination can cause corrosion, as well as mechanical and electrical faults.



## Installation

---

### 6.1 Setup

#### 6.1.1 Requirements and preparations for assembly

##### Requirements and preparations for assembly

The following general requirements for assembly must be met:

- ▶ All requirements that result from the installation conditions (see "Technical data" / "Installation conditions" chapters)
- ▶ All requirements that result from the operating conditions (see "Technical data" / "Operating conditions" chapters)

The following requirements apply for sufficient mounting stability:

The diameters of the mounting holes must be structurally proven by the manufacturer. The operator or installer is responsible for ensuring that the screw connections are tight:

- ▶ All mounting points must be and remain the same distance from the mounting level; i.e. the mounting level must remain permanently stable.
- ▶ The device's total weight must be considered when calculating the bearing strength to be borne (= device empty weight + weight of the pipe contents + additional weight such as moisture, snow or dirt).
- ▶ Requirements on the mounting screw connection:
  - Suitable screw locking
  - Tighten all screws to the same torque but do not over-tighten

#### 6.1.2 Floor installation

##### Floor installation

1. Use suitable lifting and transporting equipment to move the GIK into the planned installation position and keep it provisionally fixed there.
2. Affix sufficiently large connection screws with screw locks and tighten to the correct torque.

### 6.1.3 Installing general additional components

#### Additional components

The cooling unit manufacturer recommends installing the following additional components:

- ▶ Sensors for escaping operating fluid with a connection to audible or visual alarm units
- ▶ Shut-off devices for coolant several metres away from the insulated cooler
- ▶ Discharge devices for operating fluid that has escaped, which can be operated from potentially safe places

All safety operating elements (shut-off and discharge devices, etc.) must be designed in such a way that they can be operated by people in full protective gear.

### 6.1.4 Installation and configuration of additional hydraulic components

#### Connecting the hot gas line

The hot gas entry into the evaporator can be installed as follows:

- ▶ at the bottom in the coolant feed line
- ▶ at the top in the coolant discharge line

The project engineer specifies the hot gas distribution.

Both connection options are proven. Connecting the hot gas line to the bottom in the coolant feed line has the advantage that the frosted evaporator surfaces can be heated up evenly with just a minor temperature increase.

#### Requirements on the system circuit

A pressure-loaded relief valve, a float valve, a main valve/solenoid valve combination or similar must be installed in the condensate return line.

As the pressure in the evaporator reduces rapidly during the defrosting process (due to the sudden decrease in spec. volume when the hot gas condenses), not installing this device would result in the fluid/steam mixture flowing out of the evaporator quickly without making full use of the condensation heat. Thanks to this device, the coolant that is condensed during the defrosting process accumulates in the evaporator, in order to make full use of the condensation heat in periodical operation and to ensure that the temperature distribution in the evaporator block is even.



## Installation

---

### 6.1.5 Installing piping

#### Installing piping

Pre-install the piping and fix it provisionally to enable soldering without mechanical strains. Observe the following:

1. Install shut-off devices for the suction and fluid lines several metres away from the insulated cooler; these enable the lines to be shut off from the floor if there is a hazardous situation
2. Lay the fluid line and the suction line separately and insulate on both sides
3. Keep piping as short as possible
4. Use as few bends as possible
5. Design required bends to have as large a radius as possible

### 6.1.6 Welding or soldering piping

#### Welding or soldering piping

When welding or soldering the pre-fixed piping, observe the following:

- ▶ Use inert gas
- ▶ Avoid overheating in general
- ▶ Avoid overheating the expansion valve and its sensor in particular.

Also observe the following when soldering:

- ▶ Hard solder all connections!
- ▶ Use silver solder if the operating temperature is below -40 °C
- ▶ Use capillary soldering (use copper pipe ends that are enlarged on one side, avoid butt solder joints)

## 6.2 Air duct connection

Only cooling devices with flaps that open inwards (with radial fans) are suitable for installing air ducts.

A housing opening is prefabricated in the factory to connect the air duct.

Connect the air duct as follows:

- ▶ Plan the ducts in such a way that there is a stabilisation distance of at least two metres after the air is discharged from the housing.
- ▶ During assembly, open the defrosting valve completely to prevent the air ducts being assembled incorrectly and collisions resulting from this.
- ▶ Insert the duct into the prefabricated housing cut-out (dimensions according to the setup diagram (see appendix)).
- ▶ Screw the duct to plywood.
- ▶ Seal the circumferences of butt joints against moisture
- ▶ If necessary, make a cold cut.

## 6.3 Fan final assembly

### **WARNING**



**Hazard due to ejected rotating components if there is an imbalance**

- **Check the fan regularly to ensure that it is free of contamination, frost, icing and defects; rectify any problems immediately**
- **Check that the fans are running smoothly**
- **Check that vibration-reducing equipment is present and working**

**Vibrations and ejected parts caused by an imbalance can cause severe injuries and damage to property.**

Check and complete the fan installation as follows:

- ▶ Check that the mounting screws are tight.
- ▶ Check that the jacking points (if present) are tight.
- ▶ Check the impeller fastening.
- ▶ Do not re-use elements of loosened connections (screws, retaining rings, lock washers); replace them with new elements in order to tighten the connection again.

## Installation

---

### 6.4 Electrical connection

 **DANGER**



**Risk of fatal injuries due to electric shock!**

- Do not run cables and lines close to sharp edges or on sharp corners.
- Prevent abrasive areas, kinks, and crushing on cables and lines.
- The insulation must be suited to the possible temperatures.
- All electrical installations must be safeguarded against condensate

**Touching live parts can result in death. Damage to the insulation is life-threatening.**

**Personnel**

- ▶ Electricians

**Personal protective equipment**

- ▶ Protective overalls
- ▶ Protective gloves
- ▶ Safety boots

### 6.4.1 Preparatory inspections and installations

**DANGER**

In order to operate the machine, it is essential to have the following electrical components installed by an electrician:

- Power cable with a suitable cross section up to the machine
- Circuit breaker with the prescribed properties
- A residual current protective device for this machine
- Lockable main switch that switches off all consumers completely
- Emergency stop switch in all dangerous areas, as well as in the safe area as part of an emergency stop circuit. This emergency stop circuit must de-energise the entire machine completely and must not allow reactivation until it has been released. The emergency stop switches must be able to be operated by people in full protective gear.

The machine is only sufficiently safe to operate when all of these components are present.

**NOTICE**

Damage and failures if electrical values are incorrect.

- After completing the preparatory installation, check that the electrical values are correct.

Incorrect electrical parameters can damage the machine or can cause the product to become damaged due to deficient or failing functions.

**Steps for preparatory checks and installation:**

- ▶ Check that the local energy supply conforms to the specifications on the rating plate and the technical data (see "Technical data" / "Electrical connection" chapters)
- ▶ Ensure that the dimensions of the power cable provided by the customer conform to the machine's total power input.
- ▶ Install the power cable so that it is secured, is not a trip hazard and is protected against damage and environmental influences.
- ▶ Check that the revolving field for the 3-phase alternating current is revolving in the correct direction.



## Installation

---

### 6.4.2 Establish the electrical connection

Install the electrical equipment (for the fan drive, for ventilation, for the lighting and for the alarm system) in the installation room; observe air humidity condensation and formation of drips, as well as the hazard level of the coolant in accordance with EN 378-3: section 6.

1. De-energise the power cable provided by the customer and secure to prevent reactivation. Check that there is no voltage.
2. Install a lockable main switch
3. Install an emergency stop circuit; the emergency stop switches must be installed in all dangerous areas and in the safe area.
4. Install the circuit breaker, earth leakage circuit breaker and thermal circuit breaker in the connection box or the switch cabinet.
5. Design the wiring for the electrical consumers and the safety equipment in accordance with the circuit diagram (see appendix).
6. Insert the power cable into the connection box from the outside through the cable entry point provided for this purpose; adhere to the prescribed protection rating.
7. Connect the power cable in accordance with the circuit diagram.
8. Check that all connections are installed properly and are tight.
9. Install the connection terminal protective covers properly and check that they are tight.
10. Ensure that all insulation is in good order; rectify faults immediately.
11. Lock the connection box securely to prevent unauthorised opening.

### 6.4.3 Establish the signal connections

1. Open the connection box and insert the signal cable into the connection box from the outside through the cable entry point provided for this purpose; adhere to the prescribed protection rating.
2. Connect the signal cable to the connection terminals properly in accordance with the circuit diagram (→ appendix); adhere to the prescribed terminal configuration.
3. Check that the signal cable configuration, the insulation of the lines and the connections are tight, in perfect technical condition and installed properly; rectify faults immediately.
4. Lock the connection box securely to prevent unauthorised opening.

## 7 Start-up

### **WARNING**

#### **Risks due to incorrect installation and commissioning!**

- **Have all works in the fields of installation and initial operation exclusively implemented by employees of the manufacturer or by persons commissioned by him.**
- **Basically also commission the manufacturer with the required works in the event of later displacement, re-installation, and re-commissioning.**
- **Any unauthorised displacement, installation, and/or re-commissioning must be relinquished.**

**Installation works and initial operation require trained skilled personnel with comprehensive experiences. Installation errors may result in life-endangering situations.**

After the installation, complete mounting, initial operation processes, and the implementation of the documented test runs by the manufacturer or by persons commissioned by the manufacturer have been completed, transfer to the operator takes place.

Afterwards, intended use by the operator is admissible, taking into consideration all details in these instructions.

Have the following acceptance test carried out by an expert:

- ▶ Before starting up the device for the first time
- ▶ After replacing significant component on the device
- ▶ After making significant modifications to the device.

### 7.1 Preparing for the acceptance test

#### **Preparing for the acceptance test**

- ▶ Remove all work equipment from the insulated cooler and clean the insulated cooler.



## Start-up

---

### 7.2 Carrying out the acceptance test

#### Carrying out the acceptance test

**Document all steps and partial results of the acceptance test in an acceptance log.**

#### Entire machine

1. Mounting for the entire machine in accordance with requirements (see "Installation" / "Setup" chapters)
2. Ambient conditions in accordance with technical data (see "Technical data" / "Ambient conditions" chapters)
3. Conditions at the installation location in accordance with technical data (see "Technical data" / "Ambient conditions" chapters)

#### Electrical components

4. Electrical system in accordance with the safety requirements (see "Installation" / "Electrical connection" chapters)
5. Electricity supply values in accordance with requirements (see "Installation" / "Electrical connection" chapters and sub-chapters)
6. All electric lines and safety devices are indicated correctly and visibly
7. Functional tests of the fans (direction of rotation, input power, smooth running)
8. Fans were installed without problems (see "Fan final assembly" chapter)
9. Fan blades are protected properly
10. All screwed, welded and soldered connections are perfect after a visual inspection

#### Components with operating fluid

11. Piping is laid in accordance with requirements (see "Installation" / "Setup" chapters)
12. All piping is indicated correctly and visibly
13. Check and document the corrosion protection on all components that are not thermally insulated
14. All screwed, welded and soldered connections are perfect after a visual inspection
15. Heat exchanger is intact and clean; clean if necessary
16. Check the pressure using test gas and a test pressure that is 1.1 times the permitted operating pressure.
17. If installed by the customer: Alarm system for escaping operating fluid functioning

#### Completing the acceptance test

18. Carry out a test run of the entire machine.
19. Report all faults to the manufacturer immediately. Rectify faults after consulting the manufacturer.
20. Report all faults to the manufacturer immediately. Rectify faults after consulting the manufacturer.

### 7.3 Checking operational readiness

Use the following criteria to determine operational readiness:

- ▶ Acceptance test carried out successfully
- ▶ Device is clean and free of objects
- ▶ All electrical safety devices are operational
- ▶ Alarm system for escaping operating fluid functioning
- ▶ Ambient conditions conform to specifications

### 7.4 Starting up for the first time

The steps for starting up for the first time are identical to those for generally starting up after shut-downs, e.g. due to maintenance tasks.

1. Ensure that the acceptance test was carried out successfully and that operational readiness was checked (see previous chapter).
2. Open the feed and return valves
3. Commission the condensate drain pipe.
4. Turn on the external power supply.
5. Switch on the fan disconnection switch (on the terminal box).

The external operation and control components are used to set the parameters and activate the cooling and defrosting function, including controlling the components.

6. Wait for a few minutes and then check that the operating point is reached on external operating elements (operating point in accordance with the requirements of the entire system)
7. Secure external operating elements for adjusting the operating point to prevent access by unauthorised persons.



## Operation

### 8 Operation

#### 8.1 Safety instructions regarding operation

##### **WARNING**

##### **Risk of injuries due to improper operation!**

- Operation must only be implemented by trained personnel authorised by the operator.
- Before any works, it must be ensured that the safeguards are installed properly and work immaculately.
- Never put safeguards out of service.
- Always observe order and cleanliness in the working area! Scattered objects, components, work pieces, and tools, as well as cleaning devices are sources of accidents.

Improper operation may result in severe injuries.

#### 8.2 Emergency shutdown

In hazardous situations, the machine movements must be stopped as quickly as possible and the power supply must be switched off.

##### Emergency shutdown

In hazardous situations:

1. Switch off the power supply provided by the customer for the entire unit and secure against reactivation.
2. Notify the personnel in charge at the work site.
3. If necessary, alert the doctor and fire brigade.
4. Rescue injured personnel and initiate first aid measures.
5. Keep the access roads clear for the emergency vehicles.

##### After performing the rescue

1. If necessary, inform the relevant authorities.
2. Commission specialist personnel to rectify the fault.

##### **WARNING**

##### **Risk to life from reactivation!**

- **Prior to switching the machine back on, make sure that no one is present in the danger zone.**
3. Before starting up again, check the machine's technical condition and ensure that all safety installations are properly re-installed and fully functional.

##### Partial shutdown

##### **DANGER**



##### **Risk of fatal injuries due to power not being switched off completely.**

- Even if the disconnection switch for the fans is switched off, only touch other electrical components if the external power supply has already been switched off completely, you have checked that the system is de-energised and it has been secured to prevent reactivation.

The disconnection switch for the fans in the terminal box only de-energises the fans and not any other electrical components.

### 8.3 Overview of operating elements

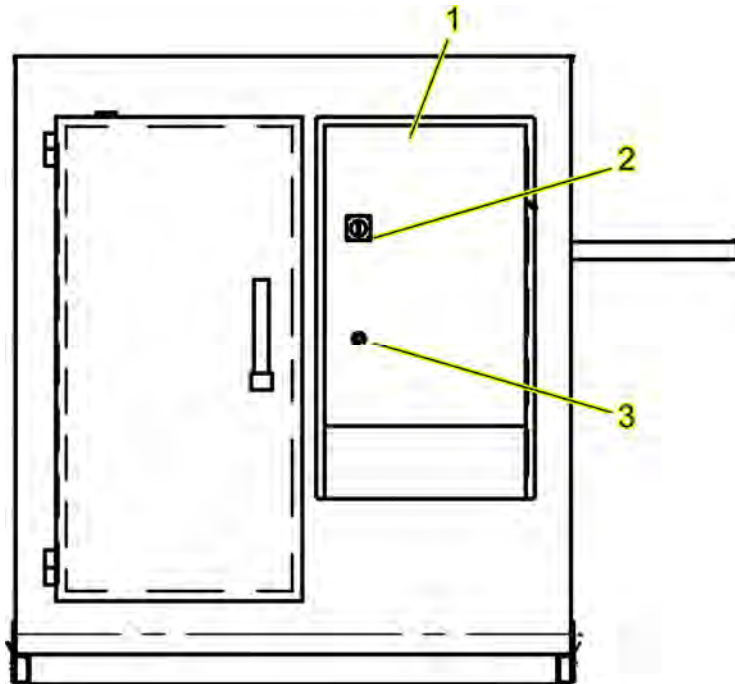

Fig. 11: GIK operating elements (example with door installed on the left)

- |   |                               |   |              |
|---|-------------------------------|---|--------------|
| 1 | Terminal box                  | 3 | Light sensor |
| 2 | Disconnection switch for fans |   |              |

### 8.4 Switching on and off

#### Switching on

The general start-up steps must be performed before actually switching on.

1. Ensure that the acceptance test was carried out successfully and that operational readiness was checked (see previous chapter).
2. Open the feed and return valves
3. Commission the condensate drain pipe.
4. Turn on the external power supply.
5. Switch on the fan disconnection switch (on the terminal box).

The external operation and control components are used to set the parameters and activate the cooling and defrosting function, including controlling the components.

#### Switching off

1. External operating elements can be used to set the power supplies for fans, heaters and flaps to zero if necessary.
2. Switch off the fan disconnection switch on the terminal box.
3. Switch off the external electrical supply completely and secure to prevent reactivation.



## Operation

---

### Partial shutdown

 **DANGER**



**Risk of fatal injuries due to power not being switched off completely.**

- Even if the disconnection switch for the fans is switched off, only touch other electrical components if the external power supply has already been switched off completely, you have checked that the system is de-energised and it has been secured to prevent reactivation.

**The disconnection switch for the fans in the terminal box only de-energises the fans and not any other electrical components.**

## 9 Failures

### 9.1 Safety instructions regarding troubleshooting

 **WARNING****Risk of injury due to improper troubleshooting!**

- Any repair work may only be carried out by instructed specialist personnel authorised by the operating company.
- Carry out any work only if the machine stands still.
- Before starting any work, switch off the power supply and secure the machine against being switched on again.
- Before starting any work, ensure that there is sufficient space for assembly.
- Always ensure and maintain a tidy and clean working area! Any objects, components, workpieces and tools as well as cleaning equipment lying around loosely are sources of accidents.
- If components were replaced, check if the spare parts have been assembled correctly. Install all fastening elements properly. Observe the screw torques.
- Prior to re-commissioning, make sure that all protective devices are installed correctly and function properly.
- Prior to switch-on, make sure that there are no people in the danger zone.

Carrying out any work improperly during troubleshooting might result in severe injuries.

 **WARNING****Risk of injuries due to unauthorised restart!**

- Switch off the power supply and protect it against restart before starting any works on individual components.

When implementing works on individual components persons may be injured when the power supply is switched on unexpectedly.

 **WARNING****Escaping operating fluid poses a risk of poisoning, injury and burns**

- Drain the operating fluid from the machine and the lines before carrying out any installation tasks
- Prevent loose connections; to do this:
- Affix the piping so that it is permanently free of vibrations and mechanical strains.
- Only have all installation and soldering tasks carried out by qualified specialist personnel
- Only use materials that are suitable for the pressures, temperatures and operating fluids that may occur

Escaping operating fluid can cause severe bodily injuries due to poisoning and chemical burns.

## Failures

### **WARNING**



#### **Danger of falling!**

- When carrying out any tasks on and in a machine that is suspended from the ceiling, close the defrosting flaps and secure to prevent inadvertent opening.
- While working at a great height, use a stable ladder or working platform with railings.
- Secure persons, tools, equipment, replacement parts, and loose objects at height against falling.
- Secure the area against access by unauthorised persons.
- In the work area, always attach and wear personal protective equipment against falling.

When working on objects at height, unsecured persons may fall or be injured by falling objects.

### **NOTICE**



#### **Ensure total cleanliness when carrying out installation and maintenance tasks.**

- Ensure total cleanliness when carrying out all maintenance and repair tasks, in particular those on components that conduct operating fluid.
- When installing for the first time: First bleed the system's transport pressure on the Schrader valve immediately before starting assembly.

Contamination can cause corrosion, as well as mechanical and electrical faults.

### 9.1.1 Behaviour in the event of failures

The following is applicable in principle:

1. In the event of failures constituting an immediate danger for persons or material assets, the emergency OFF must be triggered immediately.
2. All power supplies must be disconnected and secured against restart.
3. Inform the person responsible at the scene.
4. Depending on the type of failure, have the responsible and authorised skilled personnel determine and remedy the reason.
  1. If there are faults that present an immediate hazard for people or property, switch the machine off at the main switch immediately.
  2. Switch off all sources of energy and secure to prevent reactivation.
  3. Notify the personnel in charge at the work site.
  4. Depending on the type of fault, have the cause determined and rectified by responsible, authorised specialist personnel.
  5. If possible, keep the cooling room door closed until the specialist personnel arrive.

### 9.1.2 Troubleshooting

- ▶ Only commission persons with troubleshooting activities who have been instructed comprehensively regarding design and method of operation of the system by the manufacturer, who have been trained for the required assignments, and authorised by the operator according to the specifications of these operating instructions.
- ▶ Persons not familiar with the system, its assemblies, or individual parts who have not received any training for the required works or who do not dispose of an authorisation must never remedy failures.
- ▶ In the event of questions regarding troubleshooting or doubts regarding the proper approach, always consult the manufacturer before starting any works (address: → page 2).

### 9.1.3 Starting up again after a hazardous fault

After rectifying the error or the fault:

1. Acknowledge the error message or the fault on the controller.
2. Ensure that there is nobody in the danger zone.
3. Switch on and start the machine according to the instructions in the "Operation" chapter.



## 10 Maintenance

### 10.1 Safety instructions regarding maintenance

#### Partial shutdown



Risk of fatal injuries due to power not being switched off completely.

- Even if the disconnection switch for the fans is switched off, only touch other electrical components if the external power supply has already been switched off completely, you have checked that the system is de-energised and it has been secured to prevent reactivation.

The disconnection switch for the fans in the terminal box only de-energises the fans and not any other electrical components.



Risk of injuries due to improper maintenance!

- Maintenance works must only be implemented by instructed skilled personnel authorised by the operator.
- Before starting any works, provide for sufficient installation clearance.
- Always observe order and cleanliness in the working area! Scattered objects, components, work pieces, and tools, as well as cleaning devices are sources of accidents.
- If components have been replaced, check the spare parts for correct installation. Install all fastening elements properly. Observe the screw tightening torques.
- Before re-commissioning, ensure that all safeguards are installed properly and are functional.
- Before restart, ensure that there are no persons in the danger area.

Improper maintenance may result in severe injuries.



Risk of injury due to residual energy in components and when switching on again!

- Prior to carrying out any tasks on components, switch off the entire power supply and secure against reactivation.
- Dissipate residual energy safely (e.g. bleed compressed air).
- Prior to carrying out tasks, check that the system is de-energised (e.g. power, compressed air, spring force, etc.).
- Switch off the control unit and secure against reactivation.

## Maintenance

### WARNING



Escaping operating fluid poses a risk of poisoning, injury and burns

- Drain the operating fluid from the machine and the lines before carrying out any installation tasks
- Prevent loose connections; to do this:
- Affix the piping so that it is permanently free of vibrations and mechanical strains.
- Only have all installation and soldering tasks carried out by qualified specialist personnel
- Only use materials that are suitable for the pressures, temperatures and operating fluids that may occur

Escaping operating fluid can cause severe bodily injuries due to poisoning and chemical burns.

### WARNING



Danger of falling!

- When carrying out any tasks on and in a machine that is suspended from the ceiling, close the defrosting flaps and secure to prevent inadvertent opening.
- While working at a great height, use a stable ladder or working platform with railings.
- Secure persons, tools, equipment, replacement parts, and loose objects at height against falling.
- Secure the area against access by unauthorised persons.
- In the work area, always attach and wear personal protective equipment against falling.

When working on objects at height, unsecured persons may fall or be injured by falling objects.

### WARNING



Hazard due to ejected rotating components if there is an imbalance

- Check the fan regularly to ensure that it is free of contamination, frost, icing and defects; rectify any problems immediately
- Check that the fans are running smoothly
- Check that vibration-reducing equipment is present and working

Vibrations and ejected parts caused by an imbalance can cause severe injuries and damage to property.

### NOTICE



Ensure total cleanliness when carrying out installation and maintenance tasks.

- Ensure total cleanliness when carrying out all maintenance and repair tasks, in particular those on components that conduct operating fluid.
- When installing for the first time: First bleed the system's transport pressure on the Schrader valve immediately before starting assembly.

Contamination can cause corrosion, as well as mechanical and electrical faults.

**Personnel**

- ▶ Instructed skilled personnel authorised by the operator

**Personal protective equipment**

- ▶ Protective clothing
- ▶ Stable protective gloves when working on components, chemical-resistant protective gloves when handling hazardous substances
- ▶ Slip-resistant protective boots
- ▶ Goggles with side protection when working on pressurised components or near pressurised systems.

**10.2 Maintenance schedule**

In the following sections, the maintenance work that is required for optimum and fault-free operation is described.

- ▶ If increased wear is noticed on the components during the regular inspections, shorten the maintenance intervals according to the actual signs of wear.
- ▶ Make an entry in the service log for each service job. The log helps with fault analyses, enables the required intervals to be adjusted to the actual duty conditions and possibly to assert warranty claims.
- ▶ The performance of some of the jobs mentioned is some cases time- or load-dependent. For intervals both the periods and the operating hours (oh) apply, depending on which occurs first.
- ▶ If you have questions about service work and intervals: Contact the manufacturer.

Interval	Maintenance task	Personnel
Each time before commissioning	Check the controls and safety installation are in perfect technical condition; if necessary have defective components replaced or arrange for a repair	Trained personnel
Daily	Inspect the air intake and outlet, the heat exchanger and the fans visually for icing: If icing is frequent, increase the frequency of the automatic defrosting process	Trained personnel
Monthly	Inspect the air intake and outlet, the heat exchanger and the fans visually for contamination: If there is contamination, switch the device off and secure to prevent reactivation; then remove the contamination.	Trained personnel
	Inspect the condensate pan and the condensate drain visually for contamination: If there is contamination, switch the device off and secure to prevent reactivation; then remove the contamination carefully.	Trained personnel
Quarterly	Check the door, flap edge and drainage heater for function and wear.	Trained
	Check that the door and flap mechanism is functioning properly.	Specialist personnel
	Check that the heat exchanger block is intact and clean.	Specialist personnel
	Check that the fan is intact and running smoothly; replace the bearing or the fan blade if necessary.	Specialist personnel

Tab. 16: GIK maintenance schedule







## Maintenance

### 10.4 Maintenance works

#### 10.4.1 Defrosting

##### 10.4.1.1 Defrosting: Overview of typical process

Operating phase	Time	Components	
		Flap	Fans
Cooling	→	OPEN	ON
Suction	approx. 10 min	OPEN	ON
Defrosting	max. 30 min	CLOSED	SLOW
Dripping	approx. 5 min	CLOSED	OFF
Freezing	approx. 10 min	CLOSED	SLOW
Cooling	→	OPEN	ON

Tab. 19: Defrosting overview

### 10.4.1.2 Optimising the defrosting cycle

#### Criteria for a good defrosting cycle

The defrosting phase must be monitored during the first operating phase of the cooling system:

- ▶ The defrosting processes must be controlled in such a way that only frost and no ice is on the fin surface before the defrosting procedure.
- ▶ The entire depth of the heat exchanger block must be inspected for residual ice. An additional light source with a directional light beam is generally required for this. An increasing build-up of residual ice can destroy the cooler and result in coolant leaks. The base below the heat exchanger block or the pan must also be free of residual ice. If there is residual ice, the defrosting time or the defrosting temperature must be increased.
- ▶ If the moisture content in the housing is too high after the defrosting process (wafts of mist or increased amounts of condensate on the inside of the housing walls), the final defrosting temperature in the heat exchanger block must be reduced. Too high a moisture content also reduces the service life of the bearing and electrical components.

#### General information to optimise the defrosting cycle

The on-site system builder or operator must define the defrosting cycle and optimise it during the first few days of operation.

Thanks to intelligent, adaptive defrosting controllers, the defrosting cycle can be optimised to cooling operation, in particular if the feed and removal intervals fluctuate.

A temperature probe must be used to regulate the defrosting process. Regulation only via time switches is insufficient because they do not consider the fluctuating operating conditions sufficiently.

For information on positioning temperature probes and thermostats: see appendix.

#### Significant parameters

The following parameters are significant for determining the defrosting cycle:

- ▶ Difference between air intake and coolant evaporation point
- ▶ Quantity and frequency of feed and removal of chilled goods
- ▶ Quality and surface of chilled goods
- ▶ Presence of a pre-cooling room (with or without dehumidification)
- ▶ Presence of an air curtain system on the access points

### 10.4.1.3 Defrosting: Hot gas defrosting

#### Required hot gas quantities

In order to achieve an effective defrosting time, the hot gas quantity must be at least 3 times the quantity used during cooling operation. The condensation temperature must be at least 25 °C.

Example with NH<sub>3</sub> coolant; the ratios indicated also apply to other coolants that are permitted for this cooling unit:

- ▶  $Q_0$  = 100 kW
- ▶  $t_0$  = -40 °C
- ▶ Coolant : NH<sub>3</sub>; pump operation; circulation index  $n = 3.5$
- ▶ Cooling operation :  $m_{KM} = 250$  kg/h (pump operation:  $m_{KM} = 875$  kg/h)
- ▶ Defrosting operation:  $m_{HG} = 500$  to  $750$  kg/h



## Maintenance

### 10.4.1.4 Defrosting: Typical values

Operating phase	Desired value				Desired component state								Remarks
	Approximate default value				Default state								
	If necessary, enter the following: User experience												
	Time	Temperature at drain (thermostat)	Room temperature (sensor)	Excess temp. compared to room air (sensor)	Fluid valve	Flap	Block heater	Drain heater	Fans	Stat. htg. install. Fan drive	Suction valve	Heaters Flap and door frame, actuator	
	[min]	[°C]	[°C]	[K]									
Cooling					OPEN	OPEN	OFF	OFF	ON	OFF <sup>*A</sup>	OPEN	ON	<sup>*A</sup> ON when motor off
Suction	10 <sup>*B</sup>				CLOSED	OPEN	OFF	OFF	ON	OFF	OPEN	ON	<sup>*B</sup> until coolant completely evaporated
Close flap	02				CLOSED	> CLOSED	OFF	OFF	OFF	ON	OPEN	ON	
Defrosting	45	10	10 <sup>*C</sup>	5..10	CLOSED	CLOSED	ON	ON	RED. <sup>*D</sup>	OFF	CLOSED <sup>*E</sup>	ON	<sup>*C</sup> Heaters cycle between min. & max. temp. <sup>*D</sup> Low speed acc. to setup diagram <sup>*E</sup> Suct. v. dwell time f. prot. main valve acc. to syst. builder
		Thermostats & sensors prov. by customer; pos. acc. to setup diagram (s. appendix)											
Dripping	05				CLOSED	CLOSED	OFF	ON	OFF	ON	CLOSED	ON	
Freezing	10 <sup>*F</sup>				OPEN	CLOSED	OFF	OFF	RED. <sup>*D</sup>	OFF	OPEN	ON	<sup>*F</sup> Until res. moisture in housing & HE frozen completely <sup>*D</sup> Low speed acc. to setup diagram
Open flap	02				OPEN	> OPEN	OFF	OFF	OFF	ON	OPEN	ON	

Tab. 20: Overview of defrosting values

#### 10.4.1.5 Defrosting: Switching component heaters on and off

- ▶ Switch on the electric heaters for the flap edge, door frame and flap motors permanently for defrosting.
- ▶ Switch on the electrical drain heater around 1 hour before starting the defrosting process. Switch off when cooling operation starts.

#### 10.4.1.6 Activating defrosting function

The external operation and control components are used to set the parameters and activate the defrosting function, including controlling the components.

### 10.4.2 Clean the machine

#### Personnel

- ▶ Trained personnel

#### Personal protective equipment

- ▶ Protective overalls
- ▶ Sturdy protective gloves when working with parts, chemical-resistant protective gloves when working with dangerous materials
- ▶ Safety boots
- ▶ Light respiratory protection
- ▶ Protective goggles with side protection for work on pressurised system components

#### Instructions

If superficial contamination occurs:

1. Switch off the machine and secure to prevent reactivation.
2. Remove any icing by carrying out the defrosting procedure.
3. Remove contamination using a vacuum cleaner that is impervious to moisture. Observe the following:
  - Proceed with extreme caution to prevent damage to heat exchanger fins for example
  - Do not use any aggressive cleaning agents.
  - Dispose of cleaning cloths and processing waste in an environmentally responsible manner while adhering to applicable local provisions.
  - After cleaning, ensure that all covers and safety equipment that were opened have been locked again properly and are functioning correctly.

## Maintenance

### 10.4.3 Replacing fans

#### Partial shutdown

 **DANGER**



Risk of fatal injuries due to power not being switched off completely.

- Even if the disconnection switch for the fans is switched off, only touch other electrical components if the external power supply has already been switched off completely, you have checked that the system is de-energised and it has been secured to prevent reactivation.

The disconnection switch for the fans in the terminal box only de-energises the fans and not any other electrical components.

#### Preparing to replace fans

Carry out the following preparatory steps:

- ▶ Switch off the insulated cooler's external power supply completely, check that it is de-energised and secure to prevent reactivation.
- ▶ Switch off the fan disconnection switch at the terminal box, check that it is de-energised and secure to prevent reactivation.
- ▶ Disconnect the connection cable for the fans in the fan connection box.
- ▶ Remove the surrounding safety guard from the fans.

#### Installing the slider

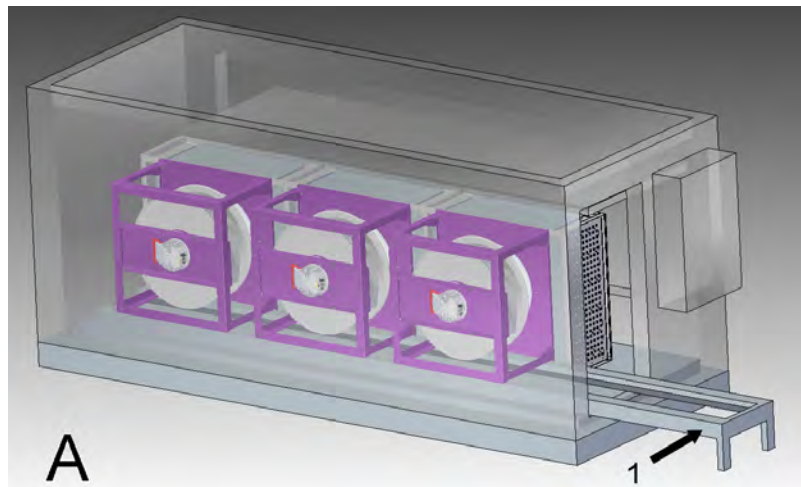
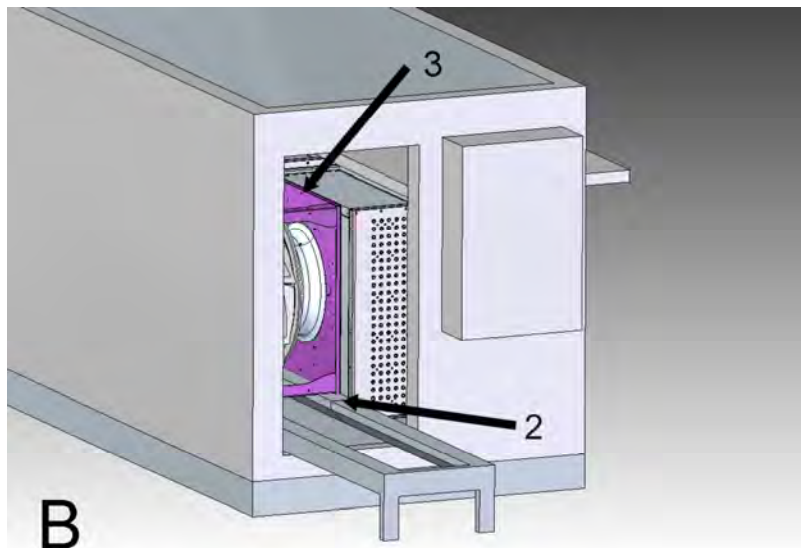

Fig. 12: Radial fans: Installing the slider

- ▶ Install the supplied slider (item 1).

**Detaching connection screws**



*Fig. 13: Radial fans: Detaching connection screws*

- ▶ Detach 4 x M10 screws (item 2) on the bottom of the bearing rails.
- ▶ Detach 12 x M10 locking nuts (item 3) from the block base plate.

**Replacing fans**

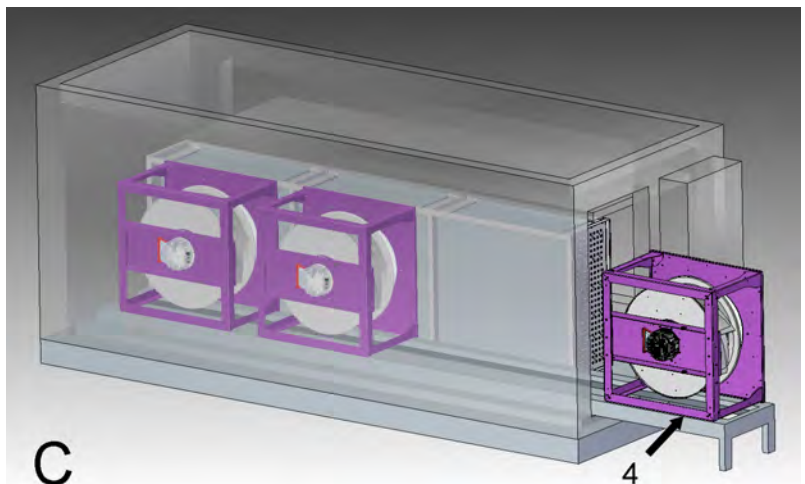

*Fig. 14: Radial fans: replacing*

- ▶ Move the fans along the slider to the replacement position (item 4).
- ▶ Lift out all fans.
- ▶ Insert new fans and move them into position.
- ▶ Attach the locking nuts to the block base plate and tighten the screws on the bearing rails (see step B).
- ▶ Remove the slider.
- ▶ Establish the electrical connection for the fans properly.



## Maintenance

### 10.4.4 Checking, retightening fastening elements

- Personnel** ▶ Skilled personnel
- Personal protective equipment**
- ▶ Protective clothing
  - ▶ Protective gloves
  - ▶ Protective boots
  - ▶ Protective helmet or impact cap

#### Information

Detail	Description or value
Interval	Monthly
Tools	Torque wrench

Tab. 21: Maintenance fastening elements

#### Procedure



### WARNING

#### Risk of injuries due to edges and corners!

- Proceed with care during work.
- Wear personal protective equipment.

1. Switch off the machine and secure it against restart.
2. All screw connections must be checked for a firm seat by using the torque wrench, retighten any loose screw connections.  
*Unless otherwise indicated, observe the current standard values for screw tightening torques.*  
*If required, replace screw connection elements which cannot be tightened with new screws and nuts.*
3. Check the technical condition of welded joints by visual and tactile inspection, immediately repair any detected defects.  
*If cracks or any other damage can be detected, determine the cause, repair the welded joint and reinforce the joints e.g. by integrating braces or additional reinforcement plates.*
4. Check the remaining fastening elements such as glued joints, pin connections, etc. by visual and tactile inspection, properly repair any loose connections.

Check that the fan assemblies are tight as follows:

- ▶ Check that the mounting screws are tight.
- ▶ Check that the jacking points (if present) are tight.
- ▶ Check the impeller fastening.
- ▶ Do not re-use elements of loosened connections (screws, retaining rings, lock washers); replace them with new elements in order to tighten the connection again.

### 10.4.5 Inspection of drive, repair

**Staff**

- ▶ Skilled workers

**Personal protective equipment**

- ▶ Basic equipment required for all work:
  - Protective work clothing
  - Protective gloves
  - Safety boots
- ▶ Extra equipment for handling lubricants:
  - Protective gloves resistant to chemical substances
  - Protective goggles with side protection for handling lubricating oils

**Information**

Data	Designation or value
Interval	Every six months
Tools	Torque wrench, mounting tools

*Tab. 22: Maintenance of drive*

**Instructions**

1. Subject driving motors, drive components and transmission elements to visual inspection to verify that they are in a technically perfect condition.
2. Replace parts with detected hair cracks, gaps, deformation or loose items by new original spare parts or have them repaired by the manufacturer or an authorized contractor.
3. Check moving components for easy operation. If necessary, replace discoloured or defective component by new original spare parts.
4. Lubricate the bearings, drive pinions, transmission und guide elements according to manufacturer's instructions.
5. Check all riveted and bolted connections and all fasteners for firm seating. Re-tighten the bolted connections where necessary or use new fasteners.

### 10.4.6 Flap adjustment

→ See appendix



## Maintenance

---

### 10.5 Measures to be implemented upon completion of the maintenance

Upon completion of the maintenance works and before switching on, implement the following steps:

1. Check all previously loosened screwed connections for firm seat.
2. Check whether all previously removed safeguards and covers have been re-installed properly.
3. Ensure that all used tools, materials, and other equipment have been removed from the working area.
4. Cleanse the working area and remove possibly escaped substances, such as fluids, processing material, or the like.
5. Ensure that all safety installations of the system work immaculately.

## 11 Disassembly and disposal

When the designed lifetime has been reached, the machine must be disassembled and disposed of in an environmentally friendly manner.

- ▶ During the planning and preparation phase for the disassembly work, consult the manufacturer of the machine for developing a safe and optimum disassembly method, taking into account the working conditions specific to the operator's site.
- ▶ Observe the local industrial safety and accident prevention regulations applicable at the site of operation during all disassembly work.
- ▶ Observe the locally applicable environmental protection and disposal regulations!

### 11.1 Safety instructions regarding disassembly and disposal

 **WARNING****Risk of injuries in the event of improper disassembly!**

- Disassembly works must only be implemented by instructed skilled personnel authorised by the operator.
- Before starting any works, provide for sufficient installation clearance.
- Always observe order and cleanliness in the working area! Scattered objects, components, work pieces, and tools, as well as cleaning devices are sources of accidents.
- Be careful with sharp-edged components, corners, and tips.
- During disassembly, always secure the components in a way that they do not fall down or tilt.
- Disassemble the components properly taking into consideration the local regulations on industrial safety and environmental protection.
- Should you have any doubts, please contact the manufacturer.

Improper execution of the works during the process of disassembly may result in severe injuries.

 **WARNING****Escaping operating fluid poses a risk of poisoning, injury and burns**

- Drain the operating fluid from the machine and the lines before carrying out any installation tasks
- Prevent loose connections; to do this:
- Affix the piping so that it is permanently free of vibrations and mechanical strains.
- Only have all installation and soldering tasks carried out by qualified specialist personnel
- Only use materials that are suitable for the pressures, temperatures and operating fluids that may occur

Escaping operating fluid can cause severe bodily injuries due to poisoning and chemical burns.

## Disassembly and disposal

### WARNING



#### Danger of falling!

- When carrying out any tasks on and in a machine that is suspended from the ceiling, close the defrosting flaps and secure to prevent inadvertent opening.
- While working at a great height, use a stable ladder or working platform with railings.
- Secure persons, tools, equipment, replacement parts, and loose objects at height against falling.
- Secure the area against access by unauthorised persons.
- In the work area, always attach and wear personal protective equipment against falling.

When working on objects at height, unsecured persons may fall or be injured by falling objects.

### DANGER



#### Danger to life due to electrical current!

- Switch off the electrical power supply and protect it against restart before starting any disassembly works.
- Have the electrical power supply disconnected from the operator network by specialised electricians.

Any contact with live parts will result in death. Damages to the insulation or individual components may be life-threatening.

### WARNING

#### Risk of injuries due to high pressure in components!

- Before starting any disassembly works, switch off and depressurise the pressurised systems.
- Check that all pressurised components are depressurised.

Pressurised components may start to move unexpectedly or suddenly.

Damages to pressurised components may result in the most severe injuries and death.

### WARNING

#### Danger to life due to falling load!

- Never stay under suspended loads.
- Do not enter the swivel range of lifting gear during operation.
- Always wear a protective helmet when working with a crane.

Falling load or parts thereof may cause the death of people.

### WARNING

#### Risk of injuries due to components swivelling out!

- Before lifting disassembled components, clear the swivel range of the lifting gear.
- Always wear a protective helmet when working with a crane.

Components where the centre of gravity is not in the middle may swivel strongly and may severely injure persons located nearby when lifted.

**WARNING**

**Danger of crushing at closely interacting parts!**

- Complete disassembly work at closely interacting parts with special care.
- Wear sturdy gloves during the work.

During disassembly of individual parts fingers and hands may be crushed due to the compact construction.

**WARNING**

**Risk of injuries due to hazardous substances!**

- Observe the safety datasheet of the manufacturer.
- Avoid spilling and the formation of mists.
- Do not eat, drink, or smoke while working.
- Avoid skin and eye contact.

Hazardous substances contain components harmful to the health and may result in poisonings, chemical burns, and skin irritations.

**CAUTION**

**Danger of injury on edges and corners!**

- When working close to sharp edges and corners, always proceed with care.
- Wear gloves.

Sharp corners and edges can cause scrapes, bruises, and cuts.

**NOTICE**

**Severe environmental damage is caused by NH<sub>3</sub> (ammonia) leaking!**

- Safely prevent coolants leaking.
- Prevent damage to all components that conduct coolant.
- Before opening the coolant lines, have a specialist company extract the coolant safely and completely by suction.

NH<sub>3</sub> (ammonia) that leaks causes severe damage to the environment.



## Disassembly and disposal

---

### Personnel

- ▶ Instructed skilled personnel authorised by the operator
- ▶ Supervisor

### Personal protective equipment

- ▶ Protective clothing
- ▶ Stable protective gloves when working on components, chemical-resistant protective gloves when handling hazardous substances
- ▶ Slip-resistant protective boots
- ▶ Goggles with side protection when working on pressurised components or near pressurised systems.
- ▶ Industrial protective helmet or impact cap

## 11.2 Disassembly

1. Switch off the machine and protect it against restart.
2. Physically disconnect the entire energy supply from the device, discharge residual energies. Check for de-energised and depressurised condition.
3. Remove operating supplies and residual processing materials and dispose of these in an environmentally friendly manner.
4. Cleanse components and assemblies properly and disassemble them observing the applicable local regulations for industrial safety and environmental protection.

## 11.3 Disposal

Unless any redemption or disposal agreements have been concluded, disassembled components must be recycled.

### **NOTICE**

#### **Environmental damages in the event of improper disposal!**

- **Have electronic scrap, electronic components, lubricants and operating supplies disposed of by specialised companies.**
- **Observe the handling and disposal regulations of the safety datasheets for hazardous substances.**
- **Should you have any doubts, please contact the manufacturer or the local municipal authorities or specialised waste management companies regarding the environmentally friendly disposal.**

**Substantial environmental pollutions may be caused by incorrect or negligent disposal.**

- ▶ Scrap metal residual parts.
- ▶ Recycle plastic components.
- ▶ Dispose of the remaining components sorted according to the material consistency.

## 12 List of figures

Fig. 1: Disconnection switch for fans, OFF ("0") position, secured with padlock .....	36
Fig. 2: Example for a warning sign when securing the machine against being switched on again .....	37
Fig. 3: Side signage: GIK with directly driven radial fans .....	39
Fig. 4: GIK front signage.....	39
Fig. 5: Rating plate .....	41
Fig. 6: Function diagram for GIK with radial fans (operation with air ducts) (I – cooling, II – defrosting).....	46
Fig. 7: Partially-transparent rear of GIK (version with radial fans - for operation with air ducts) .....	47
Fig. 8: GIK operating elements (example with door installed on the left) .....	48
Fig. 9: Transporting using lifting equipment .....	52
Fig. 10: Transporting using material handling equipment .....	53
Fig. 11: GIK operating elements (example with door installed on the left) .....	67
Fig. 12: Radial fans: Installing the slider .....	82
Fig. 13: Radial fans: Detaching connection screws .....	83
Fig. 14: Radial fans: replacing.....	83

## 13 List of tables

Tab. 1: List of revisions.....	7
Tab. 2: GIK product specifications.....	8
Tab. 3: Details on the manufacturer and people responsible for documentation.....	8
Tab. 4: Qualification requirements for personnel.....	21
Tab. 5: Sample for instruction protocol .....	21
Tab. 6: NH <sub>3</sub> (ammonia) coolant, hazards according to the safety data sheet.....	33
Tab. 7: Oils and greases, hazards acc. to safety data sheet.....	33
Tab. 8: Cleaning agents/solvents, hazards due to cleaners, solvents .....	33
Tab. 9: Type key for machine name (device name) GIK.....	41
Tab. 10: Permissible ambient conditions .....	43
Tab. 11: Operating conditions relevant for monitoring .....	43
Tab. 12: Time operating conditions .....	43
Tab. 13: GIK interfaces (fans with EC motors) .....	44
Tab. 14: Residual current protective device: Requirements.....	45
Tab. 15: Failure log, page .....	72
Tab. 16: GIK maintenance schedule .....	75
Tab. 17: Maintenance log, page .....	76
Tab. 18: Maintenance log, page .....	77
Tab. 19: Defrosting overview .....	78
Tab. 20: Overview of defrosting values.....	80
Tab. 21: Maintenance fastening elements .....	84
Tab. 22: Maintenance of drive.....	85



## Index

### 14 Index

<b>A</b>	
Abbreviations.....	9
Accident .....	38
<b>Additional components</b> .....	57
Air duct connection .....	59
<b>C</b>	
Carrying out the acceptance test .....	64
Checking operational readiness.....	65
Classification of the product.....	8
Cleaning .....	81
Cleaning agents.....	33
Components, moving .....	24
Conformity declaration .....	16
Contamination .....	26
Coolant.....	30, 33
Copyright protection.....	16
Crushing hazard .....	26
Customer service.....	16
<b>D</b>	
Danger	
Electrical lines .....	27
Dangers.....	24
Contamination and disorder.....	26
Edges and corners.....	26
Electrical current .....	27
Hot surfaces.....	28
Illegible labelling.....	32, 40
Moving components .....	24
unhealthy posture.....	32
Defrosting.....	78
Dimensions and weights.....	41
Disassembly .....	87, 90
Disconnection switch for fans .....	36
Disposal .....	87, 90
<b>E</b>	
Electric energy .....	45
Electrical connection .....	45, 60, 62
Electrical current .....	27
Electrical lines.....	27
Electricity supply .....	45
Emergency stop.....	66
Emissions.....	43
Environmental protection.....	34
Explosion protection.....	35
Exterior view .....	47
<b>F</b>	
Failure log.....	72
Failures .....	69
remedy .....	71
Fan .....	24
Fan final assembly.....	59
Fire protection.....	35
<b>Floor installation</b> .....	56
Floor installation.....	56
Function diagram .....	46
<b>G</b>	
Gear oil .....	33
Guarantee .....	15
<b>H</b>	
Hazardous substances.....	33
Hazards.....	38
Cold operating fluids.....	28
Cold surfaces.....	28
Coolant.....	30
due to operation environment	
fan.....	24
Hot operating fluids .....	28
partial shutdown.....	36, 66, 68, 73, 82
Smooth surfaces .....	26
Vibrations .....	29
Hydraulic oil.....	33
<b>I</b>	
Incorrect use.....	17
Installation .....	54
Installation conditions.....	42
<b>Installing piping</b> .....	58
Installing piping.....	58
Instruction.....	20, 21
Intended use	
incorrect.....	17
Interfaces .....	44
<b>L</b>	
Labelling.....	32, 40
Lifetime guarantee .....	15
Limitation of liability.....	15
Lubricants.....	33
<b>M</b>	
Machine operating conditions relevant for monitoring	
maintenance	
measures upon completion.....	86
Maintenance.....	73
Checking, retightening fastening elements .....	84
Clean the machine .....	81
Drive.....	85

Maintenance schedule.....	75	due to neglected ergonomic principles .....	32
Maintenance works .....	78	electric .....	27
Manufacturer specifications .....	8	mechanic .....	24
Motor oil.....	33	thermal.....	28
<b>O</b>		<b>S</b>	
Operating Conditions.....	43	Safety .....	17
Operating fluids.....	28	Disassembly and disposal.....	87
Operating instructions.....	8, 9	during maintenance.....	73
Operation.....	66	during operation .....	66
Operator .....	18	during transportation.....	49
<b>P</b>		during troubleshooting .....	69
Packaging.....	51	Safety data sheet	
Partial shutdown.....	36, 66, 68, 73, 82	Cleaning agents and solvents .....	33
Perm. ambient conditions .....	43	oils and greases .....	33
Person responsible for documentation .....	8	Safety installations .....	36
Personal protective equipment.....	22	Setup.....	56
Personnel		Short description .....	46
disassembly .....	90	Signage .....	39
Maintenance .....	75	Signal connections .....	62
Qualification .....	21	Skilled personnel.....	20
Responsibility.....	19	Solvents.....	33
Transportation.....	49	Spare parts .....	38
Personnel requirements.....	20	Specialised electricians .....	20
Personnel specialised in the field of hydraulics .....	20	Starting up again.....	71
PPE .....	22	Starting up for the first time.....	65
Preparing for the acceptance test.....	63	Start-up.....	63
Product details .....	8	Storage.....	51
Protective equipment		Storage conditions .....	51
during disassembly.....	90	Surfaces, cold.....	28
during maintenance .....	75	Surfaces, hot.....	28
during transportation.....	50	Surfaces, smooth .....	26
protective gloves .....	22	Switching off .....	67
protective gloves, sturdy .....	22	Switching on .....	67
protective goggles .....	23	Symbol definition.....	11
Protective work clothing.....	22	Symbol explanation	
safety harness.....	23	on transported goods.....	50
safety helmet.....	23	Symbols.....	9, 50
safety shoes.....	22	<b>T</b>	
safety vest.....	23	Technical data .....	41
Purpose.....	17	Terms .....	9
<b>Q</b>		Time operating conditions.....	43
Qualification .....	20	Transport .....	51
Qualification requirements .....	20	Transport inspection.....	50
<b>R</b>		Transport symbols.....	50
Rating plate.....	41	Transportation.....	49
Responsibilities .....	18	Troubleshooting .....	69
Responsibility of the personnel .....	19	<b>U</b>	
Restart, protection against.....	37	Unauthorised persons .....	22
Risks		Unhealthy posture .....	32
due to materials and substances.....	30	Use according to intended purpose.....	17



## Index

---

User requirements ..... 21

### V

Vibrations ..... 29

### W

Warranty..... 15

Wear parts..... 15

**Welding or soldering piping** ..... 58

Welding or soldering piping ..... 58

Welding work ..... 35