

Data sheet GRCspray.1 Controller GHM spray

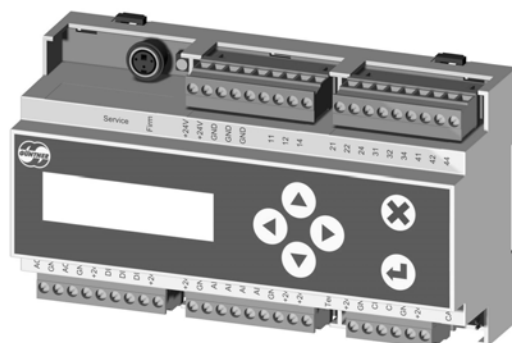

ERP no.: 5204179

www.guentner.de

Contents

1	GRCspray.1.....	3
1.1	Functional description.....	3
1.2	Configuration table.....	5
1.3	Connections.....	9
1.4	Electrical properties of.....	12
1.5	Installation / Operating conditions.....	14
1.6	Dimensions / Weight.....	15

1 GRCspray.1

1.1 Functional description

GRCspray.1 is used to manage spraying together with either a GMM speed controller with bus communication or an external speed controller without bus communication. As a minimal solution, the GRCspray.1 can control one step (variant GHM spray basic).

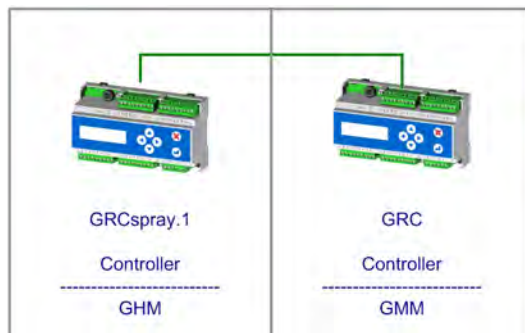

Variant GHM spray basic

If you need more steps you will need to combine the GRCspray.1 with the GIOD.1 expansion module, ERP no. 5204183 (variant GHM spray professional).

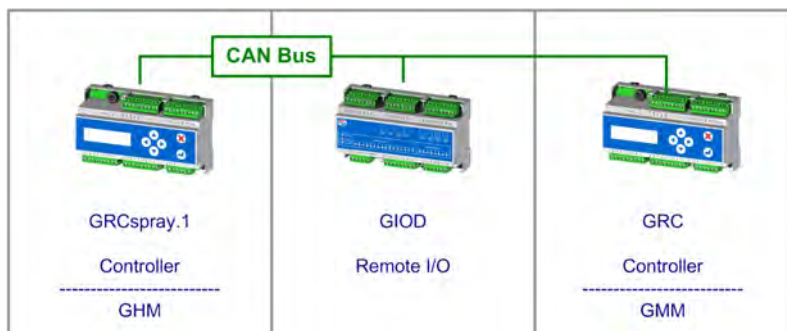

Variant GHM spray professional

In order to operate the controller it must have a power supply and must be enabled via digital input DI1. If this is not enabled the process will not be regulated.

The unit has an internal PID controller, whose parameters (amplification factor, integral time) can be configured either per menu or via an external bus module.

The spraying setpoint can be specified from the internal menu.

The current value is determined via a pressure sensor (4-20mA), a temperature sensor (KTY, GTF210) or via BUS from the GMM speed controller.

The relay outputs controlling the output stages are switched as appropriate for the setpoint and the number of steps. A switch-on threshold can be configured for each step.

The digital inputs are designed as potential-free contacts that must be connected to +24V. Spraying will be enabled only if the external enable (DI1) is connected and the fans are in operation. Fan operation is either conveyed from GMM to GHM via bus communication or by means of an additional enable (DI2). This enable (DI2) is valid only if there is no bus communication between GMM and GHM spray.

ADVICE

Please note that connecting the wrong voltage (e.g. 230V) may seriously damage the controller.

Relay outputs are used to control solenoid valves and activate warning messages. The CAN interface of the GRCspray.1 is an internal interface for communicating with other Güntner units (such as the GIOD.1 expansion module). Communications modules are available for the following external bus connections: Modbus (GCM MOD GHMspray Rail.1, ERP no. 5206138) and Profibus (GCM PROF GHMspray Rail.1, ERP no. 5206140).

1.2 Configuration table

GRCspray.1 with GMM:

	I/O	Signal	Condenser		Drycooler	
			GRCspray.1 basic	GRCspray.1 professional	GRCspray.1 basic	GRCspray.1 professional
GRCspray.1	DI1	24V	External enabling			
	DI2	24V	Starting drain from externally			
	DI3	24V	Switching to 2nd setpoint			
	AI1	4..20mA	Control value (Slave) / Setpoint (Auto external) / Free			
	AI2	4..20mA/KTY	Free	Conductivity sensor	Free	Conductivity sensor
	AI3	KTY	Free			
	AI4	0..10V	Ambient temperature / Control value (Slave)			
	AO1	0..10V	Control value / Control value from master unit			
	AO2	0..10V	Fault report: <5V = Fault, >5V = No fault			
	DO1	Relay	Solenoid valve inlet installed on site (NC) / Solenoid valve drain installed on site (NO)			
			Solenoid drain valve in the system (NO)	-	Solenoid drain valve in the system (NO)	-
	DO2	Relay	Drain signal for slave units	Drain valves in the system	Drain signal for slave units	Drain valves in the system
	DO3	Relay	Spraying solenoid valve	Solenoid valve water supply (NO) / (drain signal for slave units)	Spraying solenoid valve	Solenoid valve water supply (NO) / (drain signal for slave units)
DO4	Relay	Fault report	Section 9 or fault report	Fault report	Section 9 or fault report	
CAN BUS			Data from GMM: Pressure or return temperature/release via control valve/setpoint/heat exchanger type/refrigerant/units system			
GIOD.1	DO1	Relay	-	Section 1	-	Section 1
	DO2	Relay	-	Section 2	-	Section 2
	DO3	Relay	-	Section 3	-	Section 3
	DO4	Relay	-	Section 4	-	Section 4
	DO5	Relay	-	Section 5	-	Section 5
	DO6	Relay	-	Section 6	-	Section 6
	DO7	Relay	-	Section 7	-	Section 7
	DO8	Relay	-	Section 8	-	Section 8



The GRCspray.1 professional variant requires additional hardware (GIOD.1, ERP no. 5204183).

GRCspray.1 None GMM:





	I/O	Signal	Condenser		Drycooler	
			GRCspray.1 basic	GRCspray.1 professional	GRCspray.1 basic	GRCspray.1 professional
GRCspray.1	DI1	24V	External enabling			
	DI2	24V	Enabled: Fans ON (e.g. operating message from fan speed controller) / Starting drain from externally			
	DI3	24V	Switching to 2nd setpoint			
	AI1	4..20mA	Pressure sensor / Control value (Slave) / Setpoint (Auto external) / Free		Control value (Slave) / Setpoint (Auto external) / free	
	AI2	4..20mA/KTY	Free	Conductivity sensor	Free	Conductivity sensor
	AI3	KTY	Free		Return temperature	
	AI4	0..10V	Ambient temperature / Control value (Slave)			
	AO1	0..10V	Control value / Control value from master unit			
	AO2	0..10V	Fault report: <5V = Fault, >5V = No fault			
	DO1	Relay	Solenoid valve inlet installed on site (NC) / Solenoid valve drain installed on site (NO)			
			Solenoid drain valve in the system (NO)	-	Solenoid drain valve in the system (NO)	-
	DO2	Relay	Drain signal for slave units	Drain valves in the system	Drain signal for slave units	Drain valves in the system
	DO3	Relay	Spraying solenoid valve	Solenoid valve water supply (NO) / (drain for slave units)	Spraying solenoid valve	Solenoid valve water supply (NO) / (drain for slave units)
	DO4	Relay	Fault report	Section 9 or fault report	Fault report	Section 9 or fault report
CAN BUS			-			
GIOD.1	DO1	Relay	-	Section 1	-	Section 1
	DO2	Relay	-	Section 2	-	Section 2
	DO3	Relay	-	Section 3	-	Section 3
	DO4	Relay	-	Section 4	-	Section 4
	DO5	Relay	-	Section 5	-	Section 5

			Condenser		Drycooler	
	I/O	Signal	GRCspray.1 basic	GRCspray.1 professional	GRCspray.1 basic	GRCspray.1 professional
	D06	Relay	-	Section 6	-	Section 6
	D07	Relay	-	Section 7	-	Section 7
	D08	Relay	-	Section 8	-	Section 8

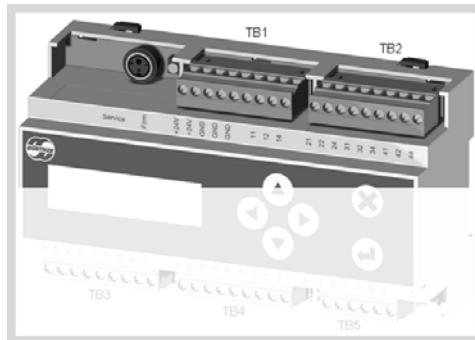
The GRCspray.1 professional variant requires additional hardware (GIOD.1, ERP no. 5204183).

1.3 Connections



Upper row of connections			
	Name	Description	
	Service	Service plug only for use by service personnel	
	Firm	Pushbutton only for use by service personnel	
TB1	+24V	External feed for power supply	
	+24V		
	GND	Contact ground for external power feed	
	GND		
	GND		
		Terminal not connected	
	11		relay DO1
	12		
	14		
TB2	21		relay DO2
	22		
	24		
	31		relay DO3
	32		
	34		
	41		relay DO4
	42		
44			

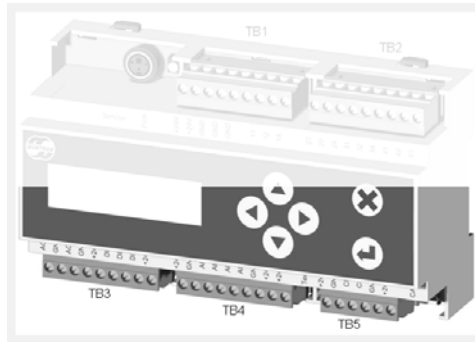

Lower row of connections		
	Name	Description
TB3	A01	Analogue output 1, 0-10V
	GND	Ground
	A02	Analogue output 2, 0-10V
	GND	Ground
	+24V	Voltage +24V
	DI1	Digital input +24V
	DI2	Digital input +24V
	DI3	Digital input +24V
	+24V	Voltage +24V
TB4	+24V	Voltage +24V
	GND	Ground
	AI1	Analogue output 4-20mA
	AI2	Analogue input 4-20mA or for temperature sensor GTF must be configured in the software
	AI3	Analogue input for temperature sensor GTF
	AI4	Analogue input 0-10V
	GND	Ground
	+24V	Voltage +24V
	+24V	
	Term	DIP switch for CAN bus termination (120Ω) / ON = termination activated
TB5	+24V	Voltage +24V
	GND	Ground
	CH	CAN high signal
	CL	CAN low signal

Lower row of connections		
	GND	Ground
	+24V	Voltage +24V
	CAN	CAN bus plug including power supply

*TB: Terminal block

1.4 Electrical properties of

	Min	Type	Max	Unit
Voltage supply	21	24	30	V
Current consumption		80	250 ¹	mA
Digital inputs				
High level	15	24	30	V
Low level	-3	0	5	V
Relay outputs				
Voltage DC		24	30	V
Voltage AC			250	V
Current resistive load 24V DC/250V AC			1	A
Current inductive load 24V DC/250V AC			1	A
Switch cycles, mechanical	1*10 ⁶			Switching cycles
Switch cycles, electrical	1*10 ⁵			Switching cycles
Voltage input				
Dielectric strength	-24		30	V
Measuring range	0		12	V
Resolution			10	bit
Fault			1	% ²
Input resistor:		230		kΩ
Current input				
Dielectric strength	-24		30	V
Measuring range	0		21	mA
Resolution			10	bit
Fault			1	% ²
Input resistance (without protective circuit)		130		Ω
Voltage output				

	Min	Type	Max	Unit
Voltage range	0		10	V
Load resistance		>=100		kΩ
Resolution			10	bit
Fault			2.5	% ²
Short protection	Yes			
Potential separation	No			
Temperature input				
Dielectric strength	-24		30	V
Measuring range	-30		100	°C
Resolution			10	bit
Precision			3	% ²
CAN bus				
Dielectric strength	-24		24	V
Transmission rate		125		kbit/s
Galvanic separation	No			

1. The maximum current consumption includes supplying two attached pressure transponders and one attached temperature sensor.
2. Of the appropriate range

1.5 Installation / Operating conditions

- The module is designed for mounting on a top-hat rail.
- All measurement and signalling lines must be connected via shielded cables.
- The shielding of measuring, signal and bus lines must be earthed at one end only.
- Suitable shielding and routing measures must be taken to ensure that mains cables and motor cables do not give rise to any interference in signal and control lines.
- Temperature:
Storage Transport: -20°C ... +70°C
Operation: -20°C ... +65°C
- Protection rating: IP 20
- Recommended cables: Belden 9841, Lapp 2170203, Lapp 2170803, Helukabel 81910

1.6 Dimensions / Weight

You will find the casing dimensions below. All dimensions are given in millimetres.

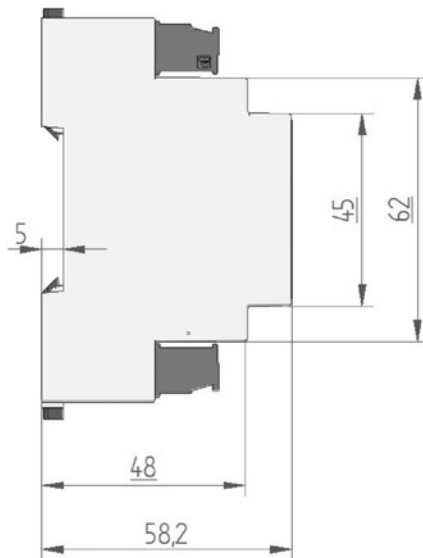
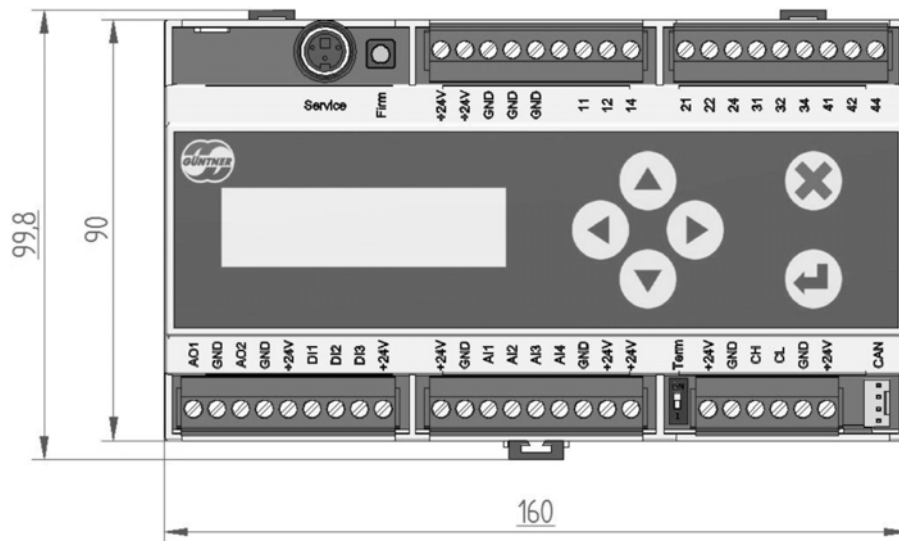

Casing dimensions of GRCspray.1

Weight:
ca. 340g