

# Data sheet GRCP.1

## Controller GMM phasecut

---

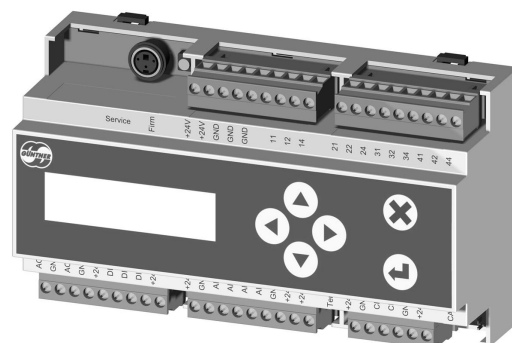

---

BAAN no.: 5204185

---

[www.guentner.de](http://www.guentner.de)

# Contents

---

<b>1</b>	<b>GRCP.1</b> .....	<b>3</b>
1.1	Functional description.....	3
1.2	Connections.....	4
1.3	Electrical properties.....	6
1.4	Installation / Operating conditions.....	8
1.5	Dimensions and weight.....	9

# 1 GRCP.1

## 1.1 Functional description

The GRCP.1 is used for controlling phase-cutting endstages. The speed of the connected fans is adjusted depending on the control deviation between the current value and the setpoint.

In order to operate the controller it must have a power supply and must be enabled via digital input DI1. If this is not enabled the process will not be regulated. The unit has an internal PID controller, whose parameters (amplification factor, integral and differential time) can be configured either from the menu or via an external bus module.

The setpoint can be given via the internal menu, an external analogue value or via an external bus module.

The current value is determined via a pressure sensor (4-20mA), a temperature sensor (KTY, GTF210) or a 0-10V signal.

The control value is sent via a bus system to the power unit (phase-cutting endstage). At the same time this value is also provided as a 0-10V signal.

The digital inputs are designed as potential-free contacts that must be connected to +24V. As well as enable, digital inputs are also used to control the night limiter (DI2) and setpoint switchover (DI3).

### ADVICE





**Please note that connecting the wrong voltage (e.g. 230V) may seriously damage the controller.**

The relay outputs are used for control messages. Relay 1 reports priority 1 alarms, relay 2 reports priority 2 alarms, relay 3 reports that the fans are in operation and relay 4 is used to signal the threshold function (GMM phasecut compact variant) or to activate hard bypass operation (GMM phasecut modular variant for switch cabinet installation).

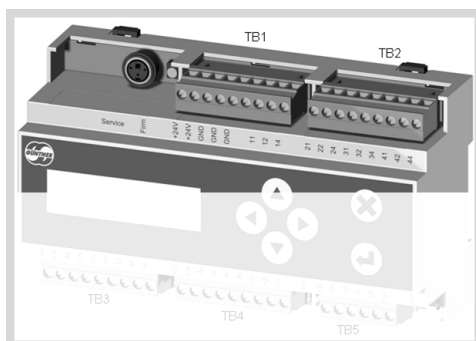
Analogue output AO1 shows the current control value from the controller (0#100%) as a voltage in the range 0#10V. Analogue output AO2 can be used to control an additional subcooler.

## 1.2 Connections



Upper row of connections			
	Name	Description	
	Service	Service plug only for use by service personnel	
	Firm	Pushbutton only for use by service personnel	
<b>TB1</b>	+24V	External feed for power supply	
	+24V		
	GND	Contact ground for external power feed	
	GND		
	GND		
		Terminal not connected	
	11		Two-way contact for priority 1 alarms
	12		
	14		
<b>TB2</b>	21		Two-way contact for priority 2 alarms
	22		
	24		
	31		Two-way contact for system messages
	32		
	34		
	41		Two-way contact: GMM phasecut compact: Threshold function GMM phasecut modular: Hardware bypass
	42		
44			

Lower row of connections		
	Name	Description
<b>TB3</b>	A01	Analogue output 1, 0#10V
	GND	Ground
	A02	Analogue output 2, 0#10V
	GND	Ground
	+24V	Voltage +24V
	DI1	Digital input +24V, Enable
	DI2	Digital input +24V Night limiter
	DI3	Digital input +24V, Setpoint switchover
	+24V	Voltage +24V
<b>TB4</b>	+24V	Voltage +24V
	GND	Ground
	AI1	Analogue output 4#20mA
	AI2	Analogue input 4-20mA or for temperature sensor GTF must be configured in the software
	AI3	Analogue input for temperature sensor GTF
	AI4	Analogue input 0#10V
	GND	Ground
	+24V	Voltage +24V
	+24V	
	Term	DIP switch for CAN bus termination (120Ω) / ON = termination activated
<b>TB5</b>	+24V	Voltage +24V
	GND	Ground
	CH	CAN high signal
	CL	CAN low signal
	GND	Ground
	+24V	Voltage +24V
	CAN	CAN bus plug including power supply

\*TB: Terminal block

## 1.3 Electrical properties

	Min	Type	Max	Unit
Voltage supply	21	24	30	V
Current consumption		80	250 <sup>1</sup>	mA
<b>Digital inputs</b>				
High level	15	24	30	V
Low level	-3	0	5	V
<b>Relay outputs</b>				
Voltage DC		24	30	V
Voltage AC			250	V
Current resistive load 24V DC/250V AC			1	A
Current inductive load 24V DC/250V AC			1	A
Switch cycles, mechanical	1*10 <sup>6</sup>			Hysteresis
Switch cycles, electrical	1*10 <sup>5</sup>			Hysteresis
<b>Voltage input</b>				
Dielectric strength	-24		30	V
Measuring range	0		12	V
Resolution			10	bit
Fault			1	% <sup>2</sup>
Input resistor:		230		kΩ
<b>Current input</b>				
Dielectric strength	-24		30	V
Measuring range	0		21	mA
Resolution			10	bit
Fault			1	% <sup>2</sup>
Input resistance (without protective circuit)		130		Ω

	Min	Type	Max	Unit
<b>Voltage output</b>				
Voltage range	0		10	V
Load voltage		>=100		kΩ
Resolution			10	bit
Fault			2.5	% <sup>2</sup>
Short protection	Yes			
Potential separation	No			
<b>Temperature input</b>				
Dielectric strength	-24		30	V
Measuring range	-30		100	°C
Resolution			10	bit
Precision			3	% <sup>2</sup>
<b>CAN bus</b>				
Dielectric strength	-24		24	V
Transmission rate		125		kbit/s
Galvanic separation	No			

1. The maximum current consumption includes supplying two attached pressure transponders and one attached temperature sensor.
2. Of the appropriate range

## 1.4 Installation / Operating conditions

---

- The module is designed for mounting on a top-hat rail.
- All measurement and signalling lines must be connected via shielded cables.
- The shielding of measuring, signal and bus lines must be earthed at one end only.
- Suitable shielding and routing measures must be taken to ensure that mains cables and motor cables do not give rise to any interference in signal and control lines.
- Temperature:  
Storage Transport: #20°C ... +70°C  
Operation: #20°C ... +65°C
- Protection rating: IP 20
- Recommended cables: Belden 9841, Lapp 2170203, Lapp 2170803, Helukabel 81910

## 1.5 Dimensions and weight

You will find the casing dimensions below. All dimensions are given in millimetres.

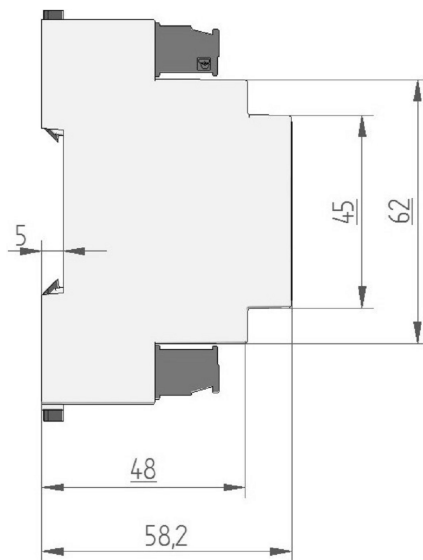
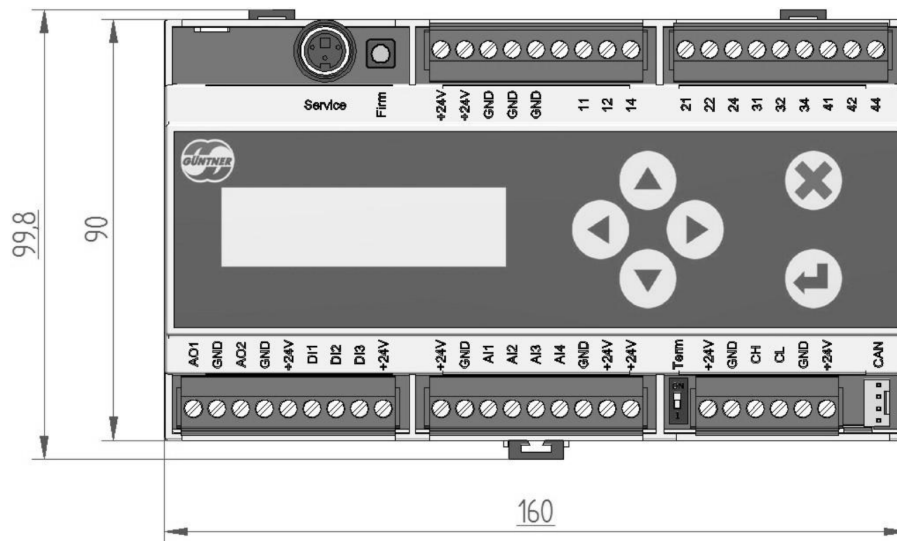

Dimensions of casing GRCP.1

**Weight:**  
ca. 340g