



Insulated Unit Cooler

GIK...

Manufacturer: **Güntner AG & Co. KG**
Hans-Güntner-Straße 2- 6
D-82256 Fürstenfeldbruck
GERMANY
Phone: +49-8141-242-0
Fax: +49-8141-242-155
E-mail: guentner@guentner.de
Internet: <http://www.guentner.de>

Subject to technical amendments without prior notice!

Version: 90046-04 GB			Page 1
31.03.10	F+E	Hollaus	
Date	Department	Name	

2. Table of contents

1. Cover sheet
2. Contents
3. Insulated unit cooler description
4. Maintenance
5. Radial fan drive
6. Flap drive
7. Repair switches
8. Proximity switches
9. Heaters
10. Defrosting procedure
11. Safety measures, general
12. Danger and installation instructions
13. Spare parts list
14. Duct connection insulated unit cooler
15. Setting for soft start (attachment 1)
16. Circuit diagram (attachment 2)
17. Installation plan (attachment 3)

3. Insulated unit cooler description

3.1 General:

This particular type of cooler has been specially designed for use in deep freezes in cases where the moisture concentration is high. The insulating housing has a flap on the front that rotates around a horizontal axis. During operation the flap is open, separating the air intake side from the air outlet. It is possible to blow straight into the refrigeration room or distribute the air in the room via a duct.

The flap is closed during the defrosting procedure. The refrigeration block and all the components inside the chamber are defrosted using air.

Efficient, economical defrosting is achieved with the insulating housing, even in the presence of large quantities of moisture and at low room temperatures.

In order to ensure that the entire cooling cell can be properly cleaned, a maintenance compartment has been provided in the interior of the insulated unit cooler cell to which the operators have access.

Another advantage of this type of cooler is the fact that it can be installed outside the actual refrigeration room, e.g. in a machine room. Maintenance work can therefore be carried out at any time without affecting the refrigeration room.

Attention! When the unit is used outdoors, a weather-proof roof is necessary!

The possibility of aeration is necessary under the insulation cooler!

The refrigeration blocks can be designed for any refrigerant or coolant, whereby NH₃ is a particularly good refrigerant. In the event of a fault, the flap and the relevant valves can be closed using an NH₃ sensor, which prevents refrigerant from entering the refrigeration room.

3.2 Device description / housing:

The devices consist of a fully insulated air cooler housing with a sandwich-type design consisting of PUR foam inside diffusion-proof top layers, providing insulation that can be as much as 200 mm thick.

The inner and outer skin consists of galvanized, plastic-coated panels. The insulation consists of CFC-free PUR foam. The entire base is designed as a drip tray.

The fan intake and discharge sides are sealed off from the refrigeration room by a distortion-proof, insulated rotating flap. The flap has a circumferential seal with a frame heater and is positioned using an actuator motor.

A door with an appropriate frame heater is provided for entering the insulating housing. The door fittings comply with the relevant safety regulations.

3.3 Heat exchanger block:

- GIKS:** The refrigeration block consists of galvanized steel:
Pipes: D = 22 x 1.2
Pipe spacing: 60 x 60mm
- GIKN:** Pipes: D = 15, for material see installation plan
Pipe spacing: 50 x 50mm
with pressed-on fins, for material see installation plan

Depending on the design, the heat exchanger block and the water collection tank/outlet can be defrosted using electricity, heating gas, glycol or a combination of these methods as required. (see installation plan)

3.4 Fans:

- Version with one, two or three rows of size 25-25 and 18-18 radial fans, or single-row version with up to 4 fans connected using torsionally elastic couplings. (see installation plan)

Caution!

The drive motors must be switched on with a adequate soft-starter or with a frequency converter.
No warranty in case of non-observance!

-
- Axial fans with different diameters and designs. (see installation plan)

The motors must be at least IP 54-compliant and have stationary heaters if required.

3.5 Wiring:

Depending on the design, all electrical components are routed to internal terminal boxes or an external terminal box or switch cabinet. (see installation plan)

4. Maintenance

The maintenance intervals for the individual components must be adhered to, and if unusual operating behaviour occurs (noise, imbalance or soiling) the operation of the insulating unit cooler must be checked by experts.

4.1 General maintenance instructions, six-monthly maintenance

Checking the door, flap edge and outlet electric heaters, and deploying or replacing the spare heater if a fault is discovered.

Function check of doors and flap mechanisms.

Checking tightness and surface protection of insulating cell and refrigerator block.

Checking air cooler block for cleanliness and foreign bodies, cleaning and removing foreign bodies if necessary.

Function test of refrigerator block and drainage tank/outlet defrosting mechanism.

Checking operation and wear of the fan drive and the radial fan bearing (lubrication, belts, elastic couplings, imbalance). Re-tightening belt drive if necessary (see 5.7), replacing wearing parts.

4.2 Radial fan description and maintenance

The fans are suitable for delivering fresh air and other non-aggressive gasses at temperatures of -30°C to 100°C .

The entire structure (housing, impeller, frame) is made from galvanized steel plate.

The impellers have blades that are bent forwards and are statically and dynamically balanced.

Bearing lubrication:

The deep-groove ball bearings are sealed at both sides and can be re-greased. The bearings must be re-greased with a **low-temperature grease** (LGL C2) or

(SKF-GMG) after 4000 hours of operation or a period of no more than **6 months**.

In order to ensure that the grease is evenly distributed the fans must be rotating by hand during the greasing procedure.

The bearing must be continuously monitored during the greasing procedure, even if the lubricating line has been moved away from the bearing in order to gain better access. Excess grease must be seen to exit from the bearing.

Caution!

- Moisture can destroy the bearing if too little grease is added!
- The seals of bearings with rubber seals may “pop out” if the bearing is filled with excessive grease, and will no longer provide an adequate seal.
Remedial measure: fitting the lip seal according to SKF-instruction.

Routine checking and servicing

The bearings of the motors until manufactured size 160L have permanent lubrication. From manufactured size 180M they can be lubricated. Lubrication is necessary for the operating time of the motors.

Bearing replacement is recommended after 20 - 25,000 operating hours at the drive motors.

4.3 Axial fan description and maintenance

Routine checking and servicing

The fan blades, the blade housing and the motor must be checked for soiling caused by dust or grease. Any soiling that could cause the motor to overheat or the fan blades to become damaged must be removed.

Bearing replacement is recommended after 20 - 25,000 operating hours at the drive motors.

5. Drive for radial fans (V-belt and toothed belt)

Drives with the correct design as far as geometry and performance are concerned will provide a high degree of operational reliability and the maximum service life. Experience has shown that an unsatisfactory service life is frequently attributable to incorrect assembly and maintenance. In order to prevent this we recommend that the following assembly and maintenance instructions be followed.

5.1 Safety

As soon as maintenance work starts it must be ensured that all machine components are in a safe position that cannot be altered whilst the maintenance work is in progress. The machine manufacturer's safety recommendations must also be followed.

5.2 Pulleys

The grooves must be manufactured in compliance with the standards and clean.

5.3 Alignment

The shafts and pulleys must be aligned before assembly.
The pulleys must not be misaligned by more than $\frac{1}{2}^\circ$.

5.4 Multi-groove drives

V-belts for multi-groove drives normally have to be measured in sets. The set tolerance must comply with the applicable standard.

5.5 Assembly

Before assembly the axle spacing must be reduced such that the belts can be placed in the grooves and onto the pulleys without force. Forcing the belts on using tyre levers, screwdrivers etc. is not permitted, since this often causes invisible damage to the high-quality, low-expansion tension cable or the sheathing fabric.

5.6 Maintenance

The drive belts must be checked for damage, wear and tension at regular intervals and must be replaced after no more than two years.
First check after circa 100 operating-hours.

5.7 Belt tension

The drive belts are correctly tensioned in the factory. Whereas toothed belts do not have to be re-tensioned, V-belts must be re-tensioned after an operating time of approximately 0.5 to 4 hours. This takes initial stretching into account.
Then the belt tension must be checked at regular intervals (six months) and corrected if necessary.

5.7.1 Pre-tension measuring via impression depth

After the measured axle force has been applied, the pre-tension f of the belt must be checked. This can be done using pre-tension measuring devices that check the impression depth (see figure 2). Adjusting the pre-tension force at the motor rail (see figure 3).

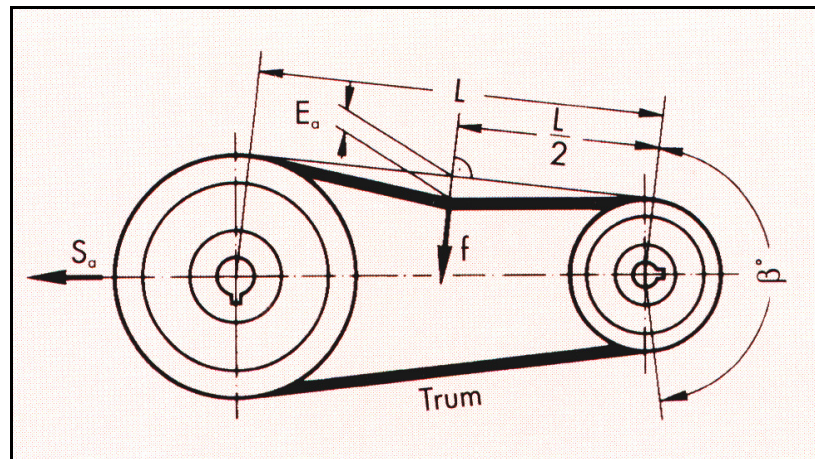

Fig 1

Setting during initial installation:
Setting during operation:
Adjusting force:

see installation plan
see installation plan
see installation plan

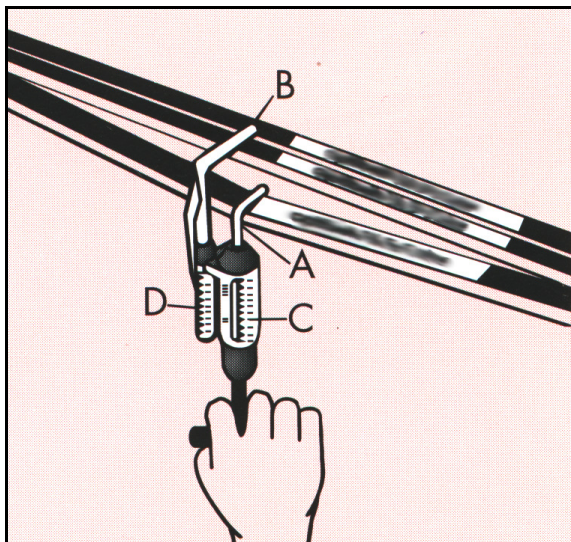

Fig. 2

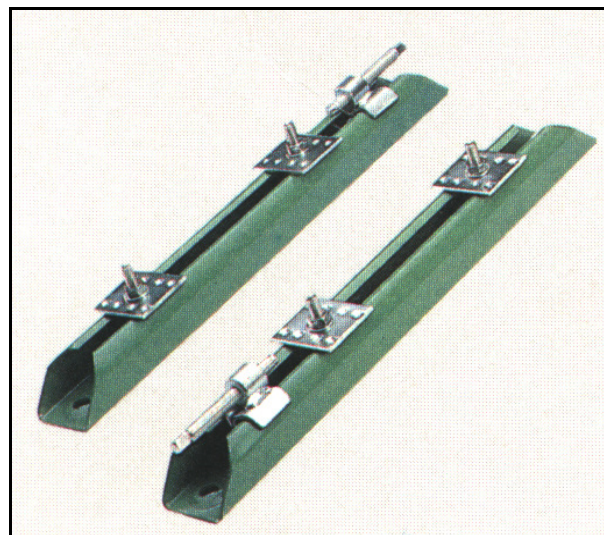
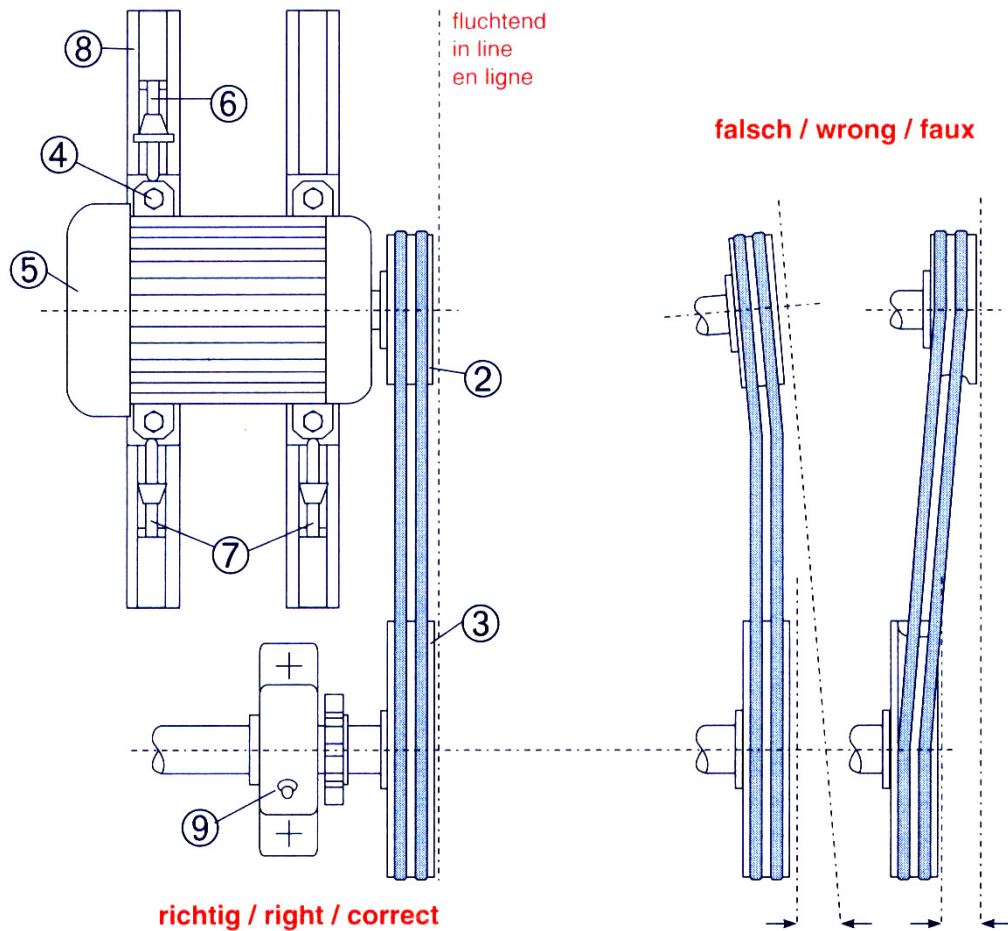

Fig. 3



The fastening bolts (4) of the motor (5) must be slackened and the support bolt (6) turned back by several turns to tension the belts. Screw in the clamping bolts (7) with the same number of turns so that the motor (5) is moved parallel to the drive shaft on the clamping rails (8). When the correct belt tension has been reached, re-tighten the fastening bolts (4) and the support bolt (6). Ensure that the belt pulleys (2), (3) are correctly aligned after re-tightening.

5.7.2 Pre-tension measurement via Trumkraft and frequency

The belt tension is set in the same way as the pre-tension measurement using these measuring methods, i.e. via the impression depth. The settings can be found in the associated installation plans.

Optibelt Optikritik Pre-Tension Measuring Devices

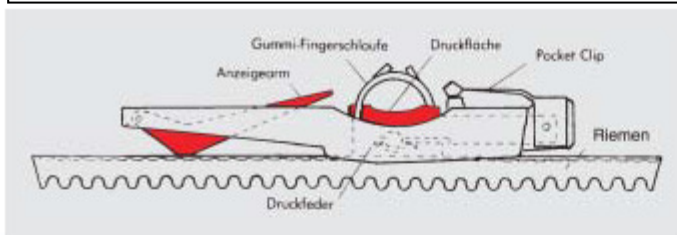

The device is used as a simplified way of pre-tensioning belts. For example, it makes it easier for the fitter to service belt drives if the technical data is unknown and it is therefore impossible to calculate the optimum pre-tension. Only the diameter of the smallest drive pulley and the profile need to be determined.

The pre-tension of the belt is read using the Optibelt pre-tension measuring device. The desired value is achieved by reducing or increasing the belt tension. Optikritik O, I, II and III devices with appropriate measuring ranges are available for the different pre-tension values.

Operating instructions

1. The measuring device is placed in the middle on the back of the belt between the two pulleys. If sets of belts are being used, it should be placed on the middle belt if possible. (Push indicator arm fully into the surface of the scale beforehand.)

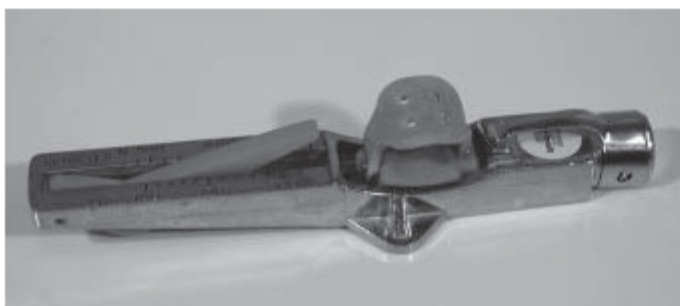

Fig. 4

2. Place the device loosely onto the belt to be measured and slowly apply pressure onto the pressure surface with a finger.

3. Avoid touching the device with more than one finger during the measuring procedure.

4. If you feel or hear a clear click, please stop pressing immediately, and the indicator arm remains in the measured position.

5. Carefully raise the device without moving the indicator arm. Read off the belt tension (see figure). Read off at intersection between top edge of indicator arm and scale surface.

6. Reduce or increase the belt tension in accordance with the measuring result until it is within the required range.

optibelt TT2

Frequency Tension Tester



The Optibelt TT2 measuring device is used for checking the pre-tension of drive belts using a frequency measurement. The display is in Hertz (Hz). When belt parameters are being entered, the pre-tension is displayed in Newtons (N).

Advantages of the device:

- contactless, repeatable measuring
- large measuring range of 10-600 Hz
- extremely accurate
- quality of measuring result is evaluated
- storage in database
- easy to use
- universal measuring head for convenient measurement
- data communication via PC

6. Flap drive, actuator motor **(executed till 01.04.2009)**

Electrical linear actuator, 230 VAC,
force 3000 N, stroke 145 mm

Type NOP-30230-145 /K4/BLM List 8.0
NORM-PLUS

APPLICATION

NOP-30230-145 /K4/BLM Linear actuator for linear motion applications or damper applications. For damper applications this actuator can be attached to a crank arm. The actuators are 100 % overload protected and can be stopped in any position. The controller must be stable and should not pulse.
Application: For industrial plants.

TECHNICAL DATA

Type	NOP-30230-145 /K4/BLM
Supply voltage	196... 264 VAC
Power consumption	~30 VA at 230 V for the actuator ~53 VA at 230 V for the heater
Stroke max.	145 mm
Force	3000 N
Running time	~90 sec.
Control mode	on/off, with permanent supply voltage
Feedback	-
Weight	~9 Kg
Endswitches	No endswitches, actuators are overload protected. Disconnection after 30 s. Restart by change of direction or short removal of the operating voltage.
Ambient temperature	-40 °C... 50 °C
Housing material	Aluminium, baked varnish
Rod material	high-grade steel
Protection acc. EN 60529	IP 56
Heater	The inserted heating is regulated on 20°C / 30°C.
Operating mode	DIN 0530 S3 80%ED minimum run time of the actuator >1 sec.
Included	Actuator with 1 m cable, 2 linkages
Installation area	Safe area

This actuator is not
explosionsproof!

CE



ACCESSORIES

/K4 Extended heating to -40°C.

DIMENSIONS

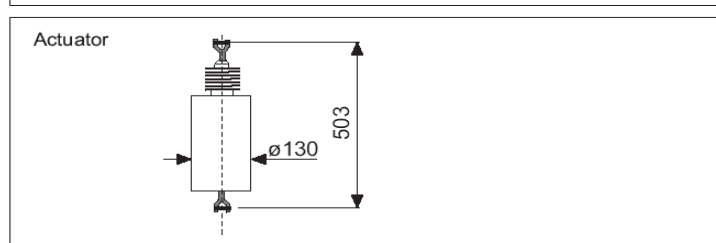

ATTENTION!

- For installation, use and maintenance the official rules and standards must be applied.
- The cable of the actuator must be installed in a fixed position and protected against mechanical damage.
- With using in environments with strong temperature modifications a heater is necessary. For outdoor installation a heater and a weather protective housing against rain, snow and sun is required.
- In normal use, the supply voltage must be permanently applied to the actuator.
- In order to preserve the connected load, the drive switches off with a continuous blockade after 30 s. For a restart a direction change or a short removal of the operating voltage is necessary.

ELECTRICAL CONNECTION

Attention: • Voltage at terminal 3: rod is extending.

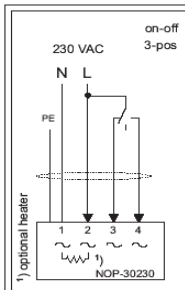

With colours instead of
numbers on the cable:
1: blue
2: brown
3: black
4: black

The flap can be moved manual with a switch which is placed in the outside clamping box or control cabinet.

Attention! Don't dismount the actuator motor from the flap! Danger of actuator motor damage!

For condensate avoidance the power supply of the actuator motor will only be broken for repair work. No warranty in case of non-observance!

6.1 Flap drive, actuator motor

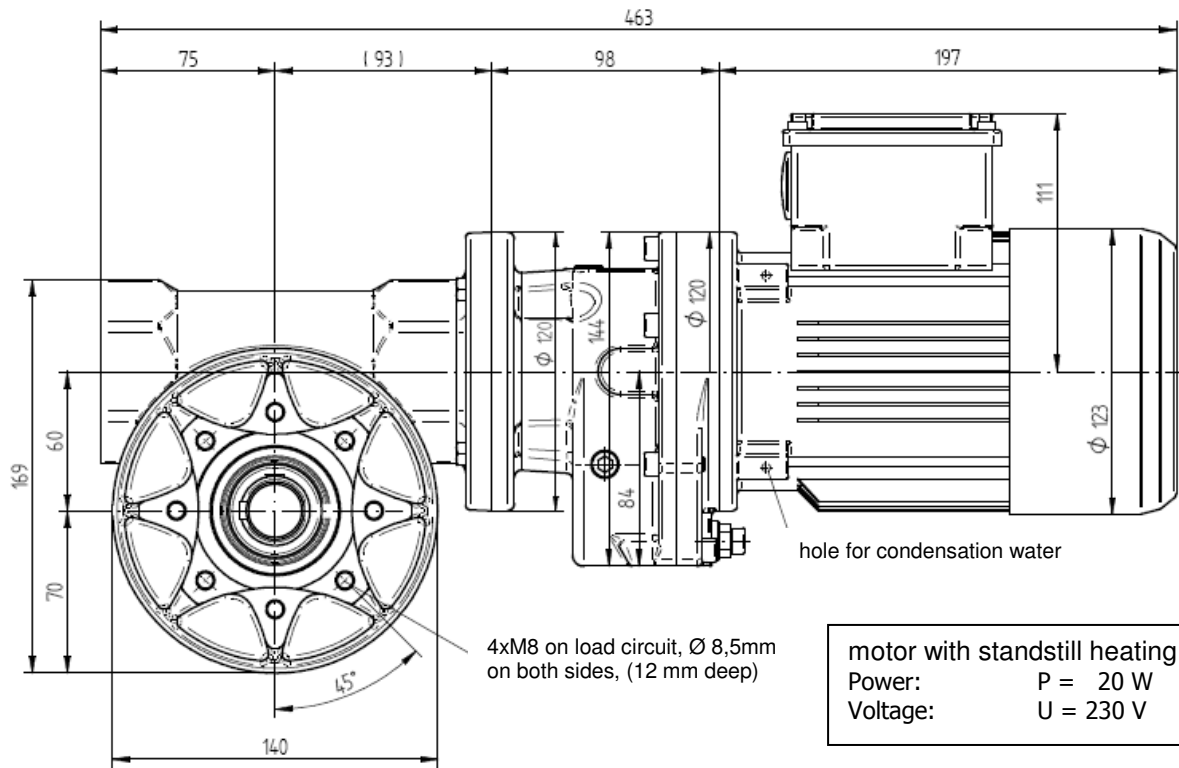

bore hole for cable gland screw

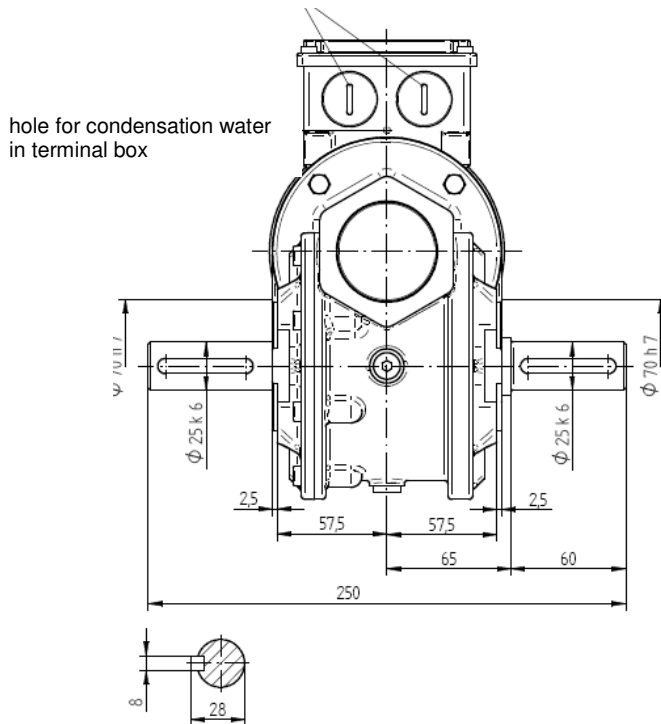

installation position OV

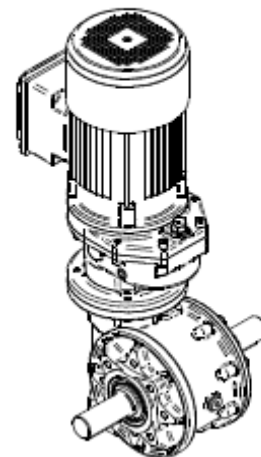

Parallel key according to DIN 6885/1 Center holes to DIN 332/2

Flap drive, actuator motor

Technical data:	
Power	[kW] : 0,18
Voltage	[V] : 230/400
Frequency	[Hz] : 50
Nominal current	[A] : 1,2 / 0,7
Output speed	[min ⁻¹] : 1,2
Gear ratio	: 1 : 1102
Protection class	: IP 55
Insulation class	: F
cos φ	: 0,66

Worm Gear
CB 2S 060/00 – 63N/4D - Fb Wb
Output shaft Ø 25 x 60 + Output flange C 105 on both sides
Motor with standstill heating

Electrical connection

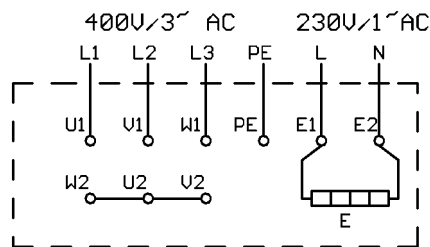

WARNING!

- For installation, commissioning, operation and maintenance the regulations for electrical equipment have to be observed.
- The flap can be tested manually with a manual switch in the terminal box or switch cabinet, however only test with sight contact to flap and stop immediately when the final position is reached.
- Do not separate flap from actuator motor, this also applies to manual testing (Open-Close). Danger of damage to actuator motor!
- Oil change after 24 months at the Bockwoldt actuating drives
Oil: Aeroshell Fluid 4 (-60°)

For prevention of condensate, the supply voltage for the standstill heating (E) of the actuator motor may only be disconnected for maintenance/repair
In case of non-compliance, no warranty can be given!

6.2 Flap adjustment

View inside insulation cooler

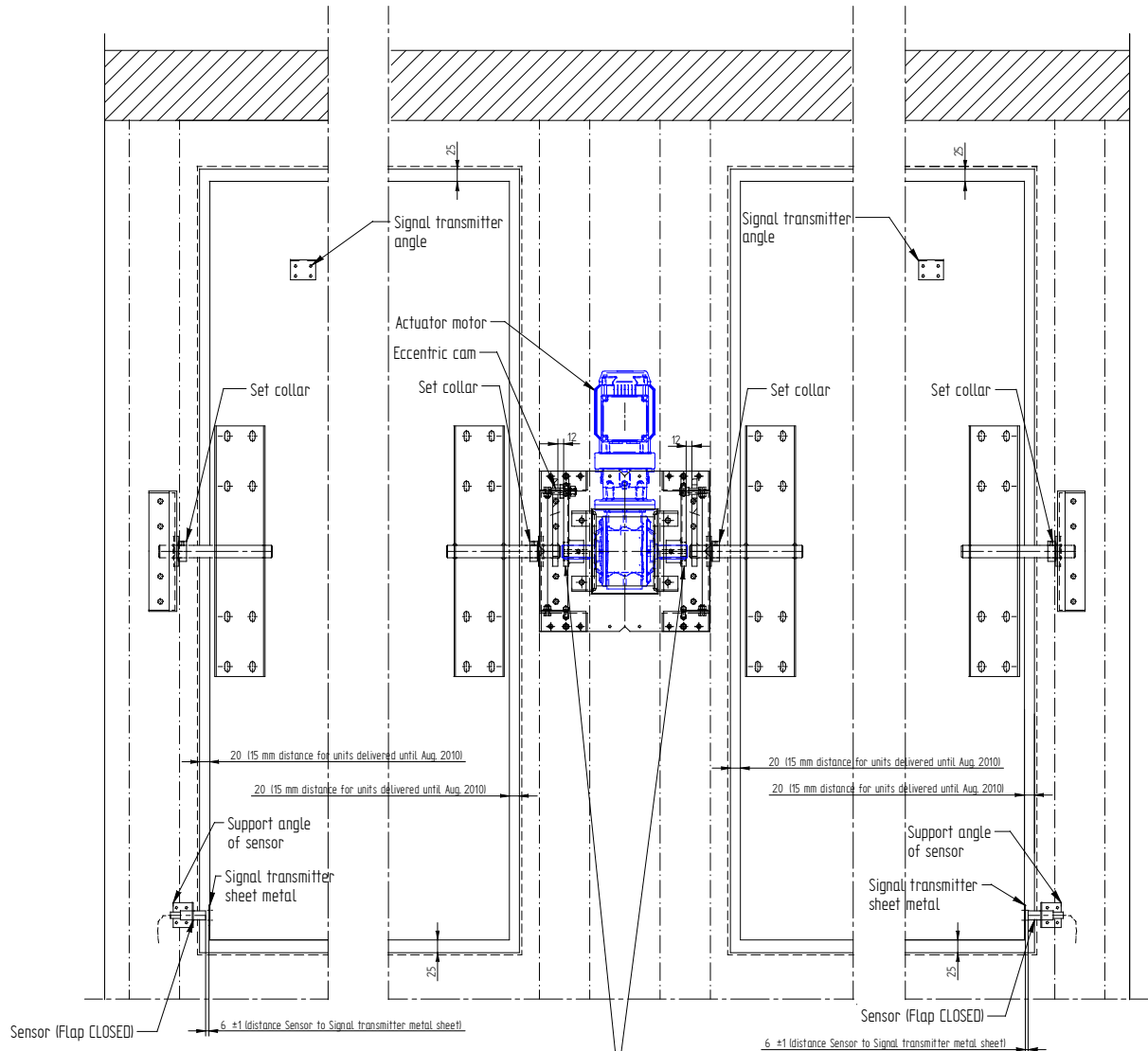

The sensors Flap „open“ – „closed“ are set so that the opened flaps have a distance of 10mm to the flap stop and/or the coil's top edge and that the closed flaps are closed flush.

Warning: The flap may not touch the coil's top edge and/or the flap stop.

Vernier adjustment of both flaps together is effected with the eccentric cam.

The flaps are depicted axially with the dimension shown in the drawing. The adjustment is effected via regulating rings. Hexagon socket screws are secured with Loctite medium strength.

Warning: With 2 flaps both sensors have to give a signal for turning off the actuator motor.

Flaps can be unhinged in case of air duct installation (by customer) by moving axially both motor levers. For putting the flaps back into position secure hexagon socket screw with Loctite medium strength.

Side view flap adjustment

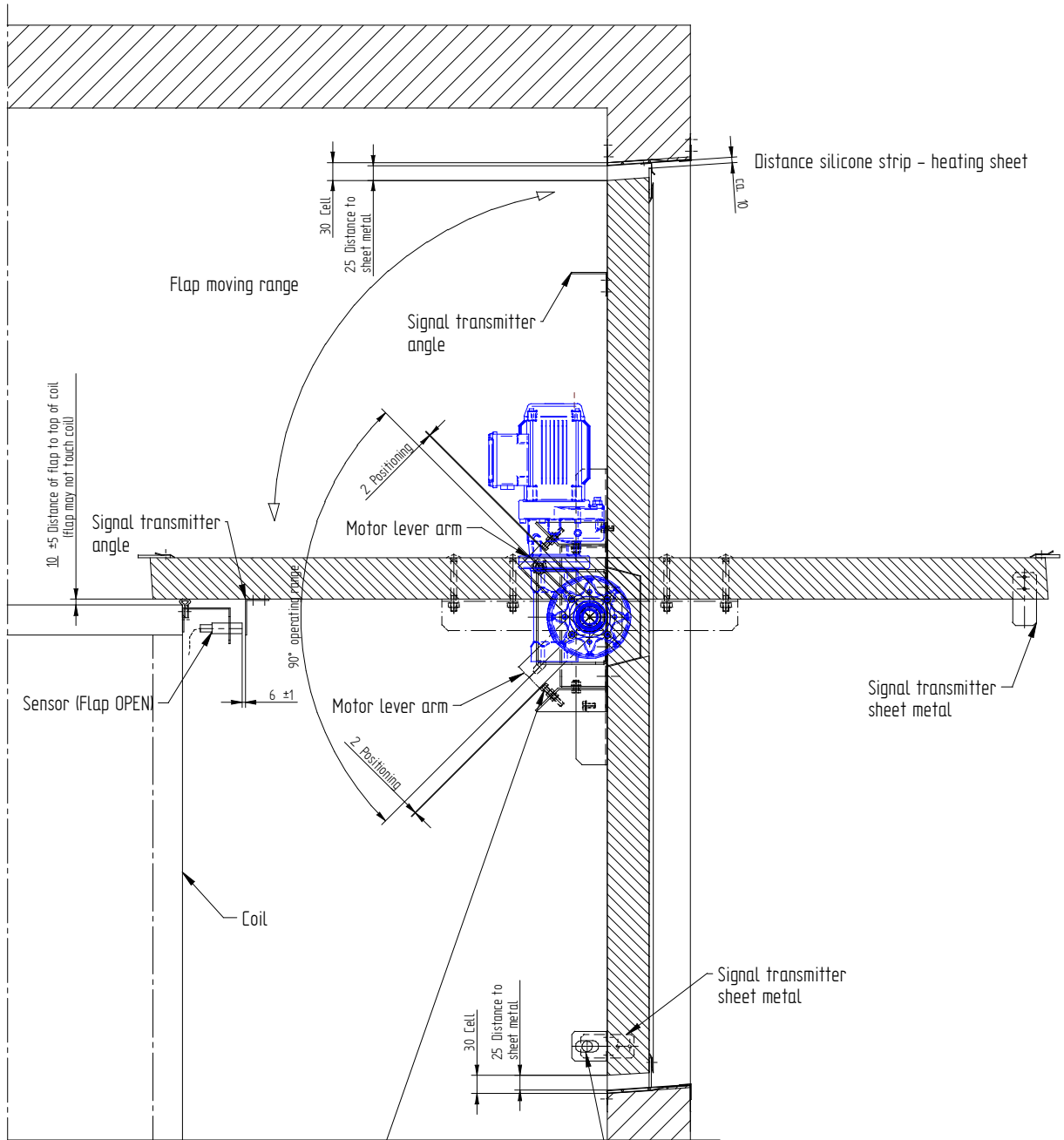

The distance of the final position of the motor lever to regulating screw is 2 mm.
 Warning: The motor lever may not drive against the regulating screw.

Sensor (Flap CLOSED)



7. Technical data for repair switch model:

Typ: H233-41611-281M1

(at work)

Typ: H216-41340-281M1

(at work)

8.0 Inductive proximity switch

Article code 60879

IGM209

IGKC3008BBSKG/M/US
Metal thread M18 x 1
Plug-in connection

Increased switching distance
Gold-plated contacts
type approval

switching distance 8mm [b]
flush mountable

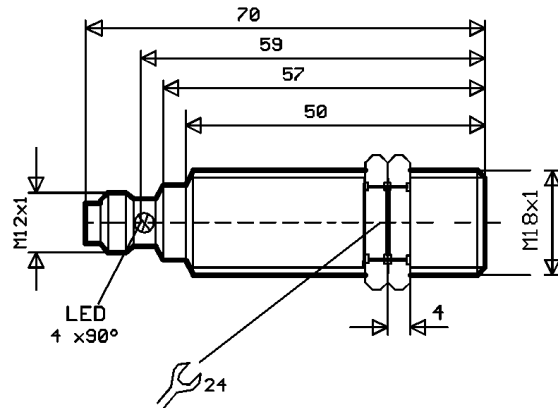

Electrical design

DC PNP

Output function

normally open contact (NOC)

Operating voltage [V]

10...36 DC

Current-carrying capacity [mA]

100

Short circuit protection, clocked
reverse-polarity protected / overload-
proof

ja

Voltage drop [V]

ja / ja

Current consumption [mA]

< 2.5

Protected sensing distance
[mm]

< 10**

6.48

Environmental audit

Vibration resistance (EN 60068-2-6 Fc):

20g; 10...3000Hz; at -20 °C and +50 °C; 50 frequency cycles; 1 octave/minute;
on 3 axis

Shock resistance (EN 60068-2-27 Ea):

100g; 11ms half sine; 3 shocks each in each direction of the
3 coordinate axis at -40 °C and 85 °C

Resistance to continuous shocks (EN 60068-2-30 Eb):

40g; 6ms; 4000 shocks each in each direction of the 3 coordinate axis at -20 °C
and 50 °C

Thermal shock (EN 60068-2-14 Na):

TA=-40 °C; TB=85 °C; t1=30min; t2=<10s; 50 cycles

Salt spray fog testing (EN 60068-2-52 Kb):
Severity level 5 (4 test cycles)

Hysteresis [% / Sr]

1...20

Switching frequency [Hz]

200

Correction factors

steel (St37) = 1 / V2A approx. 0.7 / Ms approx. 0.5 / Al approx. 0.45 / Cu
approx. 0.35

IGM209

Ambient temperature [°C] | -40....85 |

Protection type, protection class | IP 67 / IP 69K |

EMC

Automobile sector
 Emitted interference and resistance to interference immunity acc. to automobile directive 95/54/EG (e1 type approval)
 Resistance to interference immunity acc. to DIN ISO 11452-2: 100 V/m
 Conducted disturbance acc. to ISO 7637-2:

Pulse	1	2	3a	3b	4	5
Severity level	IV	IV	IV	IV	IV	IV
Failure criteria	C	C	A	A	A	C

EN 61000-4-2: CD: 4kV / AD: 8kV
 10V/m
 EN 61000-4-3: (80...1000MHz)
 2kV
 EN 61000-4-4: mains line to line:
 EN 61000-4-5: 0,5kV
 10V
 EN 61000-4-6: (0,15...80MHz)

EN 55011: Class B

Casing materials | Casing: stainless steel
 Active surface: PBTP |

Function display
 Switching status LED | yellow (4x90°) |

Connections | M12 plug-in connection, gold-plated contacts |

Connection diagram

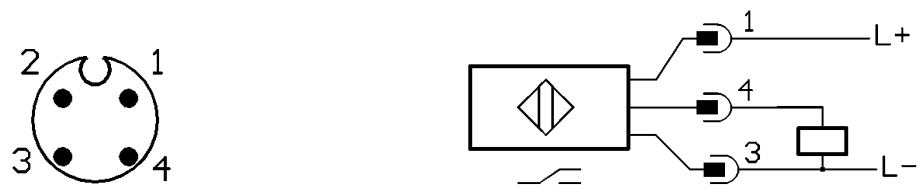

Accessories (included) | 2 mounting nuts |

Subject to technical amendments without prior notice!

8.1 Cable Socket

Article code 4187 for Inductive proximity switch Article code 60879

EVC004

Cable socket
for sensors with
M12 plug-in connection

free of silicone
free of halogen
gold-plated contacts

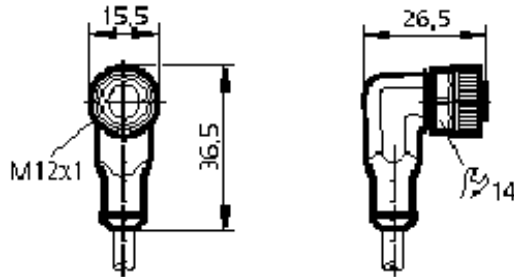

Electrical design	AC/DC
Operating voltage [V]	250 AC / 300 DC
Current-carrying capacity [A]	4 *)
Design	angled
Operating temperature [°C]	-40...90
Protection type	IP 67 / IP 68 / IP 69K •
Material of handle	casing: TPU orange; gasket: viton
Material of union nut	brass; nickel-plated
Starting torque union nut [Nm]	0,6...1,5
Connection	PUR cable / 2 m 4 x 0.34 mm ² (42 x Ø 0.1 mm); Ø 4.9 mm; free of halogen
Colour of coating	black

Connection diagram

Colours of insulated wires

BK black
BN brown
BU blue
WH white

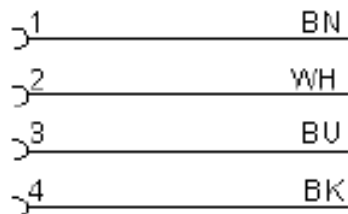

Remarks

*) cRUus: 3 A

— Subject to technical amendments without prior notice. — GB - EVC004 - 27.07.2006

9. Door and flap edge heating

Nominal cable resistance: from 250 Ω /km
to 30 000 k Ω /km
Nominal temperature: 250 $^{\circ}$ C
Loading capacity: 30 W/m
Test voltage: 3000 V
Nominal voltage: 300/500 V
Door edge: see inst. plan
Flap edge: see inst. plan
Heating cables with silicone insulation and silicone jacket.



9.1 Tray and drainage channel heating: See installation plan for number of heaters

L	V	kW
see installation plan	230	see installation plan

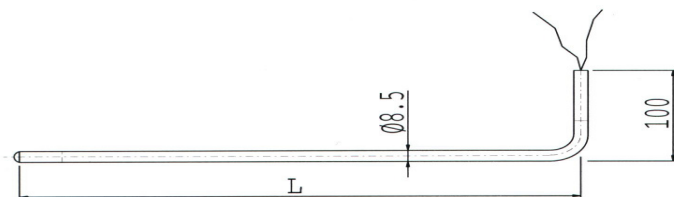

9.2 Coil heating: See installation plan for number of heaters

L	V	kW
see installation plan	400	see installation plan

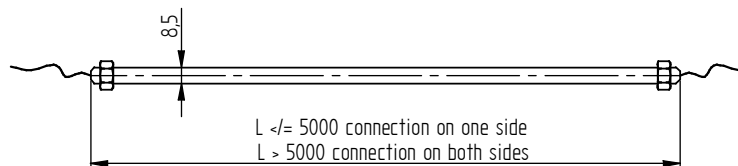

9.3 Outlet heater

Heating element	Resistance wire made from CuNi or NiCr alloy
Insulation	Silicone
Cross-section	Oval, approx. 5 x 7 mm
Termination	Water-tight silicone sleeve
Cold end	1 m
output	40 or 50 W/m
tolerance	+/- 10 %
Max. permitted surface temperature	200 °C
Min. permitted surface temperature	-70 °C
voltage	230 V

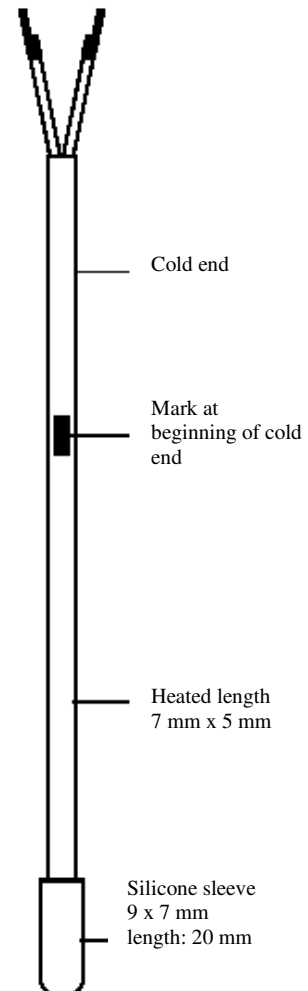

Notes: The length of the cold end is always 1 m. Shortening the cold end is not permitted!

The heated length is 1.5 m.

Do not subject heating cable to continuous operation!

Permitted operating temperature must not be exceeded.

10. Description of defrosting procedure with electric heating or hot gas for insulated unit cooler

10.1. Defrosting cycle

The defrosting cycle

- 2 x daily
- 1 x daily
- at 2-day intervals
- at 3-day intervals

must be defined by the system operator.

The defrosting cycle essentially depends on:

- System parameters (the greater the difference between the air inlet temperature and the evaporation temperature, the more frequently defrosting is required)
- Refrigeration material (packed or unpacked)
- Charging and removing intervals (including daily operating time or weekend operation)
- Pre-cooling room arrangement (with or without refrigerating material dehumidification)
- Air curtain system arrangement

The defrosting cycle must be optimised by the system builder or operator on site. However, it can be effectively adapted to refrigeration operation by using intelligent, adaptive defrosting controllers, particularly with varying charging and removal intervals.

10.2. Defrosting procedure and parameters

The following table containing the defrosting procedure and the defrosting parameters is only for use as a basis. The values must be individually adapted to the respective conditions for each insulating unit cooler.

This is particularly important during the initial days and weeks after start-up, whilst the refrigerating building is being cooled down for the first time. Appropriate control parameter and component adaptations (temperatures, temperature sensor positions, valves and times) are needed.

During normal operation, the entire defrosting procedure must be checked at least every quarter and whenever the operating conditions change.

Failure to comply with this will invalidate the warranty.



	Refrige- ration	Suction	Close flap	Defrosting	Dripping phase	Freezing phase	Open flap	Refrige- ration
Duration in min	-	approx. 10 *1)	approx. 2	approx. 45	approx. 5	approx. 10 *5)	approx. 2	-
Defrozing thermostat in defrosting operation (on site). Pos. inst. Plan	-	-	-	max. 10°C	-	-	-	-
Room temp. sensor in cooling operation (on site). Pos. inst. plan	-	-	-	max. 10°C *3)	-	-	-	-
Excess temp. Protection sensor in insulating unit cooler (customer provided)	-	-	-	max. 5K to 10K via room temperature sensor	-	-	-	-
Liquid valve	Open	Closed	Closed	Closed	Closed	Open	Open	Open
flap	Open	Open	Close	Closed	Closed	Closed	Open	Open
Heater, block and tray	Off	Off	Off	On	Off	Off	Off	Off
Drainage channel heater	Off	Off	Off	On	On	Off	Off	Off
Fan	On	On	Off	Low speed	Off	Low speed	Off	Off
Fan drive stationary heater	Off *6)	Off	On	Off	On	Off	On	Off *6)
Suction valve	Open	Open	Open	Closed *4)	Closed	Open	Open	Open
flap edge, door edge, actuator motor heater	On	On	On	On	On	On	On	On
Outlet heater	Off	On *2)	On	On	On	On	On	Off
Remark		*1) until refrigerant has fully evaporated. *2) approx. 1 hour before start of defrosting procedure		*3) heaters cycle between min and max temperature. *4) suction valve dwell time for protecting the main valve as defined by system builder.		*5) until all remaining moisture in WT block and housing has frozen		*6) on, if motor is off

Chronological defrosting procedure

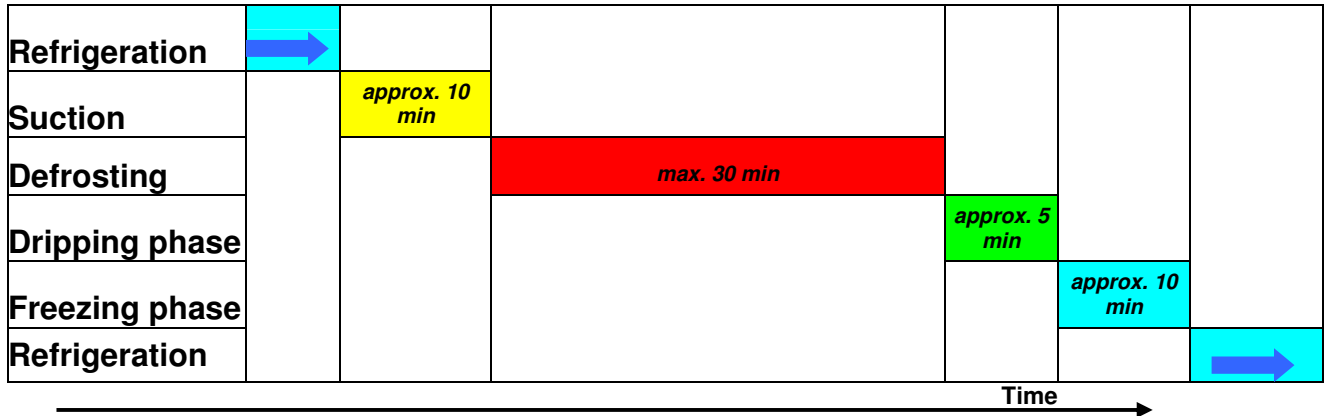

Flap	Open	Open	Closed	Closed	Open
Fans	Operation	Operation	Reduced	Off reduced	operation

The defrosting phase must be monitored during initial operation of the refrigeration system. The results of the defrosting must be visually inspected:

1. The defrosting procedure must be controlled such that the fin surfaces are only covered with hoar frost before defrosting starts, and not ice.
2. The entire depth of the heat exchanger block has to be examined for residual ice. An additional light source with a directed light beam is usually required for this. Additional residual ice build-up can destroy the refrigerator and cause refrigerant leaks! The ground beneath the heat exchanger block and the tray must also be free from residual ice. If residual ice is present, the final defrosting temperature in the heat exchanger block must be increased, or the hot gas quantity or the temperature must be increased.
3. If there is too much moisture in the housing after the defrosting procedure (vapour or additional condensation on the inner walls of the housing) the final defrosting temperature in the heat exchanger block must be lowered. Too much moisture also reduces the service life of the bearings and electronic components.

The defrosting procedure must be controlled using temperature sensors. Timer control is inadequate, since timers do not take varying operating conditions into account to an adequate extent. If the final defrosting temperature is not reached, shut-off takes place at the defined time (cause must be determined and remedied).

The defrost thermostat for defrosting the cooler is mounted in the entry space on top opposite the insulating flaps (see mounting plan). (Mounting by customer on-site)

The room temperature sensor for cooling operation is placed in the range of the air flow on top opposite the insulating flaps (see mounting plan). (Mounting by customer on-site)

The electric flap edge, door edge and flap drive motor heaters of the insulating unit cooler must be switched to continuous operation.

The electric drain heater must be switched on approx. 1 hour before defrosting starts and switched off when refrigeration starts.

Before starting the defrosting, the final position sensor (for closing the flap) "Close" has to operate, then the defrost process can start. Defrost is effected with ambient air and at a reduced speed of the radial fans or at revised sense of rotation of axial fans. Before switching to refrigeration mode the final position sensor for opening the flap has to operate, only then die fans can be turned on again.

The activation of the actuator motor for opening/closing the flap(s) has to be turned off immediately when the final position of the sensors (flaps) and of the drive is attained. If the flaps do not reach the final position "Open" or "Closed", the drive for the actuator motor has to be turned off (danger of damage!), after a time interval of 3 to 5 seconds. An alarm with the message "Flap of cooling cell x did not close after defrosting/open before defrosting" has to appear and all power input for this cooling cell has to be turned off.

For manual testing of flaps with manual switch (open/close) no automatic turning off is necessary. Danger of actuator motor damage!

10.3 Special features of hot gas defrosting

10.3.1 Hot gas line integration

The hot gas can enter the evaporator

- at the bottom in the refrigerant inlet line
- at the top in the refrigerant outlet line

The routing of the hot gas is defined by the planners.

Both integration methods have proven themselves in the field. Integrating the hot gas line at the bottom in the refrigerant inlet line has the advantage that the frosty evaporator surfaces are heated evenly with a small temperature increase.

If a drip tray is used, the hot gas must always enter the hot gas pipes of the drip tray first, then enter the block. A non-return valve must be integrated depending on the hot gas routing.

10.3.2. Required hot gas quantities

In order to achieve an effective defrosting time, the quantity of hot gas must be at least 3 times the quantity of the medium that is used during refrigeration. The condensation temperature must be at least 25 °C.

Example:

- Q_0 = 100 kW
- t_0 = -40 °C
- Refrigerant: NH_3 ; pump operation; circulation number $n = 3,5$
- Refrigeration: $m_{\text{KM}} = 250 \text{ kg/h}$ (pump operation: $m_{\text{KM}} = 875 \text{ kg/h}$)
- Defrosting: $m_{\text{HG}} = 500 \text{ to } 750 \text{ kg/h}$

10.3.3. System shut-off requirements

Since the pressure in the evaporator drops quickly during the defrosting procedure (because of the sudden decrease in specific volume when the hot gas condenses) and the liquid/vapour mixture would therefore flow out of the evaporator quickly without making full use of the heat generated by condensation, a pressure-loaded overflow valve, a float valve, a main valve/solenoid valve combination or the like must be installed in the condensation return line.

The overflow valve or the like has the job of causing the refrigerant that is liquefied during the defrosting procedure to build up in the evaporator, in order to make full use of the condensation heat during periodic operation and ensure that the temperature is evenly distributed in the evaporator block.

11. General safety measures

The following precautionary measures must be taken during the installation or use of fans:

1. No work should be carried out on the fan without the main switch being switched off and protected from being switched on again, or the motor has been completely isolated from the electrical feed.
2. If the fan has to be assembled before installing in the system, it must be checked that all fastening bolts are firmly seated. The strength of any lifting points that are present must also be checked.
3. The strength of the fastening bolts and secure fixing of the components must be checked continuously during routine servicing. It is imperative for the impeller attachment to be checked at regular intervals.
4. Devices for preventing bolts from unscrewing such as snap rings and serrated washers must never be re-used. If bolts are loose, the snap rings and serrated washers must be replaced with new ones.
5. If the fan is installed in a location where it is possible for someone to touch the fan blades, a safety grille must be fitted. It is the responsibility of the company that installed the devices and the operator to ensure that local safety regulations are complied with.
6. If a fan is installed in such a way that broken parts could cause personal injury, precautions must be taken to make sure that such injury is avoided.
7. A risk analysis for the insulating unit cooler has been performed.

12. Danger and installation instructions

12.1 Danger instructions for NH₃

Technical parameter:	Refrigerant	:	NH ₃
	Filling volume	:	see installation plan
	Permitted pressure above atmosph. :		28 bar

Danger notes: The NH₃ air cooler is filled with NH₃. NH₃ is:



**FLAMMABLE
EXPLOSIVE
CAUSTIC
TOXIC
FROSTBITE** and can cause



Topping up with other refrigerants is not allowed!

Smoking and open flames are prohibited in all working areas!

Personal protection equipment:

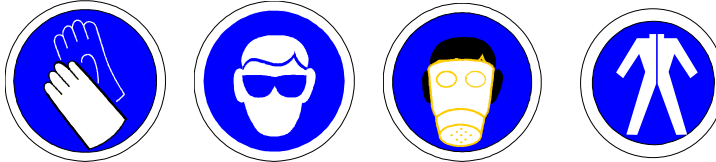

**Safety gloves
Eye protection
Breathing protection
Personal protection
equipment**

First Aid



1. Instructions on health risks and what to do in the event of accidents.
2. See a **doctor** after **inhalation** and **causticization**, particularly to the eyes.
3. **Take injured persons out of contaminated atmosphere**
4. **Remove contaminated clothing**
5. Make injured person **breathe fresh, damp** acidified air (passed through 7% concentration of acetic acid)
6. **Do not allow injured person to breathe in deeply – restrict movements to minimum**
7. If injured person **stops breathing – give artificial respiration immediately**
8. **Rinse causticized parts of the body with plenty of water** (acidified if possible)

12.2 Danger instructions for Ethylene Glycol

Operating instruction in accordance with § 20 of the GefStoffV (Hazardous materials legislation) for the handling of ethylene glycol

Ethylene Glycol

Description: Colourless, slightly viscous, slightly volatile hygroscopic liquid that can be mixed with water, flammable, with sweetish taste and odour.

Synonyms: Ethane diol, glycol

CAS No.: 107-21-1

Formula: $C_2H_6O_2$



Hazardous to health

Protective measures and rules of behaviour

Keep away from ignition sources – do not smoke

Avoid contact with hair, eyes and clothing! Wear suitable protective gloves, safety glasses and protective clothing! Remove soiled, saturated clothing immediately.

Keep sealed cylinder in a well-ventilated location, away from ignition and heat sources.

Dangerous reactions

Violent reactions can be expected if the material comes into contact with oxidation agents such as chromic-sulphuric acid, potassium permanganate or fuming nitric acid.

Explosive in contact with air at high temperatures in vapour/gaseous form.

Other instructions:

After skin contact: Slight irritation. Risk of skin resorption.

After eye contact: Slight irritation. Mucous membrane irritation.

After swallowing: Excitation. ZNS problems.

Systemic effects: After a latency period: tiredness, ataxia (lack of coordination), unconsciousness, kidney damage.



What to do in dangerous situations

Escape route: Leave danger zone by the nearest escape route or escape window.

If the material is spilled or escapes, collect using universal binding material (Chemizorb[®]) and hand in as special waste specifying the substance that has been collected. Universal binding material is available free of charge from the environmental protection and work safety department.

In the event of fire: The fire extinguishers that are available in all main areas can be used in case of fire. (take part in the environmental protection and work safety department fire fighting exercises so that you are trained in the use of fire extinguishers).

Suitable extinguishing materials: CO₂, foam, powder, water spray.

Make fire service aware of the dangerous combustion gasses/vapours!

Special dangers: Vapour is heavier than air.

Emergency number: Tel.: 112

First aid

After inhalation: Provide fresh air immediately!

After eye contact: Locate nearest eye bath! Rinse eyes for several minutes with lids open! **Call a doctor!**

After skin contact: Rinse immediately with plentiful amounts of cold water! Remove contaminated clothing!

After swallowing: Drink large quantities of water. **Have affected person transported to casualty department in an ambulance immediately!**

Notes for doctor: Give these instructions to the doctor. The following pages contain important information regarding treatment!

First aiders: See notice! **First aiders must take care not to become affected themselves!**

12.3. Safety instructions for Refrigerants: **134a, 407A, 407C, 407D, 404A, 508 and 23**

What has to be considered?

The refrigerants are hydrofluorocarbons (HFC's) that have been liquefied under pressure. Because of their low boiling point they are extremely volatile and cool down rapidly when they evaporate. The vapour that they produce is heavier than air. High concentrations can therefore build up near the ground in poorly ventilated areas.

All refrigerants are slightly toxic (poisonous). The manufacturer's recommendation for the maximum workplace concentration (MAK) is 1000 ppm. However, extremely high concentrations can cause life-threatening heartbeat irregularities and asphyxiation because of the low oxygen content of the air.

The refrigerants are not flammable at normal pressure and temperature. However, HFC/air mixtures can be flammable at high pressure and must therefore be avoided. When thermal decomposition occurs (e.g. coming into contact with naked flames) poisonous and caustic vapours are created (e.g. hydrogen fluoride).

How do I protect myself?

Like all work involving operating materials, the handling of refrigerants is subject to work hygiene standards. Depending on the situation, this means wearing suitable protective clothing, protective gloves and safety glasses or a face mask in order to avoid contact with the skin and eyes,



since liquid splashes or spray can cause freeze burns to the skin and the eyes.



Working areas must be well ventilated in order to prevent the inhalation of high vapour concentrations. Do not smoke or drink alcohol when working with the materials.



Refrigerants must not be allowed to come into contact with naked flames, since this could create toxic combustion products. For this reason, welding and soldering work must only be carried out after all refrigerant has been removed from the component(s) concerned. It must also be ensured that



good ventilation is provided. Always wear breathing gear that is independent of the ambient air when carrying out emergency work in high refrigerant concentrations.

How can I ensure that plant and machinery rooms are safe?

Adherence to the limits can be ensured at all times by monitoring the refrigerant concentration in the air. Electronic warning devices are available from specialist retailers.



If good ventilation and extraction facilities are provided, the levels can easily be kept well below the permitted limits.

Escaping refrigerant damages the environment and leads to unnecessary expenditure. For this reason the systems must be regularly checked for leaks, which must be remedied immediately.

What has to be considered during storage and handling?

The containers must be kept in a well ventilated location and also protected from ignition sources, sunlight and heat – in which case they can be stored safely and without problems, even for long periods.

The storage location must be as cool as possible and dry. In order to prevent escaping refrigerant from entering other rooms, the materials must not be stored near intake openings for air conditioning systems or boiler systems, or stored near open ducts. Like all pressurised cylinders, the containers must be protected from accidents. The cylinders must not be thrown away.

Filling with liquid refrigerant can cause electrostatic charging. Adequate earthing must therefore be provided. The wearing of thermally insulating gloves is recommended when transferring liquid gas, since the gas will cool rapidly if it escapes.

What should be done in the event of a fire?

The firefighting facilities must always be adapted to the environment. The containers can explode if they are overheated. A jet of water can be used to cool down the containers.



The thermal decomposition products that occur during HFC combustion are caustic. For this reason, breathing gear that is independent of the environment and full body protection must be worn in the event of a fire.

12.4 Installation and operating instructions

- The power supply to the unit must be cut off during installation and maintenance work.
- The plant must be secured against unintentional reactivation during this work.
- The national and international safety regulations must be observed for all electrical installations (e.g. UVV 20, VGB4, VDE 0100).
- All electrical installations must be carried out by trained experts.
- Live parts must be covered.
- The motor connection wiring diagrams in the terminal box must be complied with.
- Correctness of wiring and earthing must be checked before starting up.
- The nominal current values printed on the motor name plate must be complied with and compared with the actual values.
- The fan rotating direction must be checked.
- All supply lines to terminal sockets must be sealed in accordance with the - protection class of the socket.
- With radial fans the test running of the motor for measuring current strength must only be carried out with the housing closed and the air supply attached.
- If the fan switching is progressive, the power consumption at each individual switching stage must be checked. It must also be ensured that the permitted switch-on frequency of the fan is not exceeded. The motor may otherwise become thermally and mechanically overloaded.
- The supply line must always be fused in accordance with the smallest wire cross-section within a bundle of wires.
- The information on the individual component name plates must be noted and the system designed accordingly.
- Always attach the duct with the flap fully open in order to ensure that the flap does not come into contact with the duct when it opens.

13. Spare part list, version with radial fans

Designation	Description / article code	Technical data	Quantity	Remark
Flap edge heater	Heating cable	see inst. plan	3 pcs. / flap	see 9.
Door edge heater	Heating cable	see inst. plan	2 pcs. / door	see 9.
Drainage heater	Heater cable / HS 28	L=1500, 230V, 75W	1 pc./ flap	see. 9.3
Tray heater or outlet channel heater	Heater element	see inst. plan	see inst. plan	see 9.1
Coil heater	Heater element	see inst. plan	see inst. plan	see 9.2
Actuator motor till 01.04.09	Linear actuator	Drive 30W, 230V heater 53W, 230V	see inst. plan	see 6.
Actuator motor	Worm gear actuator Oel: Aeroshell Fluid 4	Drive 180W, 230V heater 20W, 230V	see inst. plan	see 6.
Limit position sensor	Inductive proximity switch / 60879 and 4187	10-36V DC, 0.1A	2 pcs. / flap	see 8.
Fan bearings	Contact Güntner		2 pcs. / fan see inst. plan	
Drive belt	V-belt / toothed belt	see inst. plan	see inst. plan	see 5.
Drive motor	Three-phase current motor	see inst. plan	see inst. plan	
Grease for fan bearing	SKF-LGL C2 or SKF-GMG			
KTR coupling	Gear ring 95/98 Sh8 Size 42			

13. Spare part list, version with axial fans

Designation	Description / article code	Technical data	Quantity	Remark
Flap edge heater	Heating cable	see inst. plan	3 pcs. / flap	see 9.
Door edge heater	Heating cable	see inst. plan	2 pcs. / door	see 9.
Drainage heater	Heater cable / HS 28	L=1500, 230V, 75W	1 pc. / flap	see. 9.3
Tray heater or outlet channel heater	Heater element	see inst. plan	see inst. plan	see 9.1
Coil heater	Heater element	see inst. plan	see inst. plan	see 9.2
Actuator motor till 01.04.09	Linear actuator	Drive 30W, 230VAC heater 53W, 230V	see inst. plan	see 6.
Actuator motor	Worm gear actuator Oel: Aeroshell Fluid 4	Drive 180W, 400V/3~; heater 20W, 230V	see inst. plan	see 6.
Limit position sensor	Inductive proximity switch / 60879 and 4187	10-36V DC, 0.1A	2 pcs. / flap	see 8.
Axial fan	see inst. plan	see inst. plan	see inst. plan	
Grease for fan bearing	SKF-LGL C2 or SKF-GMG			

14. Duct connection insulated unit cooler

Schnitt B-B/
view/ image en coupe

Zur Vermeidung einer Kältebrücke kann die Isolierzellenverkleidung umlaufend im Bereich der Kanalisierung aufgeschnitten werden. Nach Kanalmontage muss die Stoßfuge umlaufend gegen Feuchtigkeit abgedichtet werden.
To avoid the formation of a thermal bridge, the casing of the insulated unit cooler can be cut open at the duct insulation. After the duct is connected, the butt joint has to be sealed completely against moisture.
Pour éviter la formation d'un pont thermique, le revêtement de la cellule isolé peut être coupé à l'isolation du gainé. Après avoir raccordé le gainé, le joint doit être rendu complètement étanche contre l'humidité.

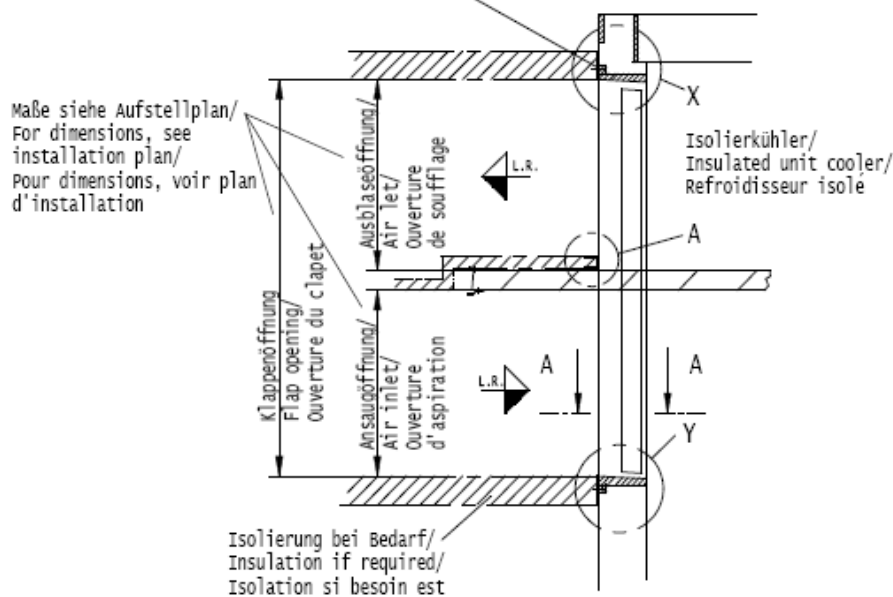

Schnitt A-A/
view/ image en coupe

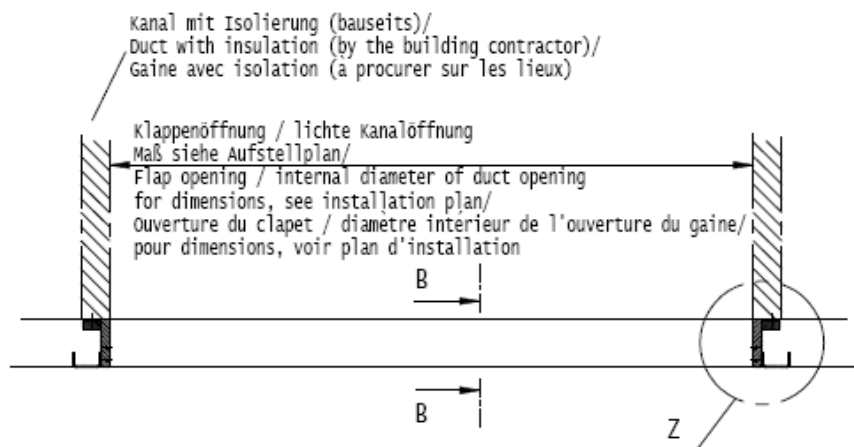

Detail X

M 1:5

Schichtholz für Kanalbefestigung/
plywood for tunnel mounting/
Raccordement du gaine
Refroidisseur isolé

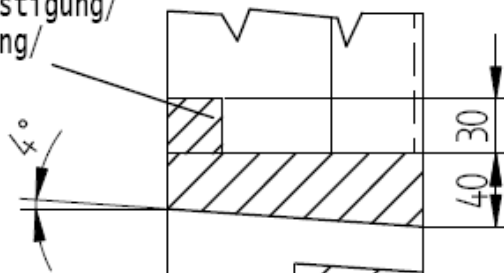

Klappe/
flap/
clapet

Detail Y

M 1:5

Schichtholz für Kanalbefestigung/
plywood for tunnel mounting/
Raccordement du gaine
Refroidisseur isolé

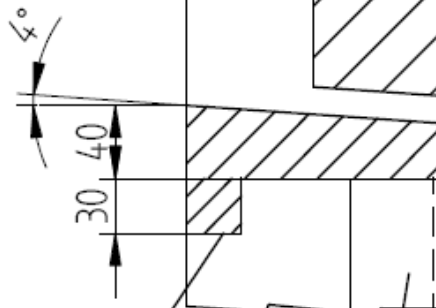

U-Stahl 100x50x5/
U steel/
profilé en U

Detail Z
 M 1:5

Schichtholz für Kanalbefestigung/
 plywood for tunnel mounting/
 Raccordement du gaine
 Refroidisseur isolé

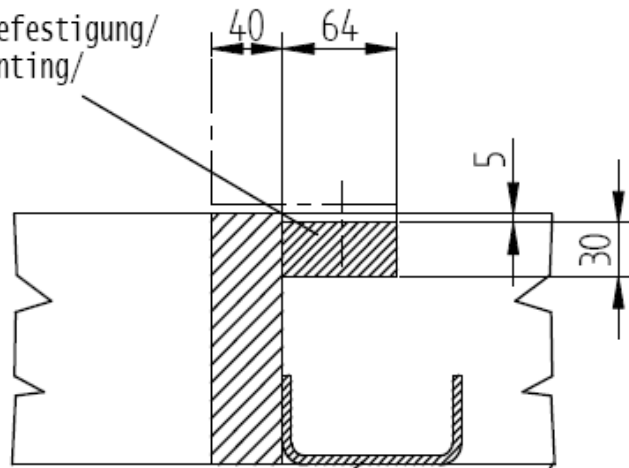

U-Stahl 100x50x5/
 U steel/
 profilé en U

Innenseite/
 inside/
 intérieur

Detail A
 M 1:5

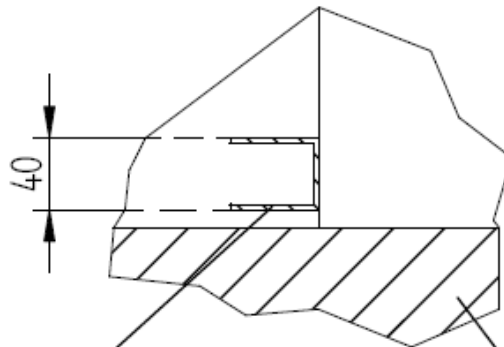

U-profil bauseits/
 U profile (provided by building contractor)/
 profilé en U (à procurer sur les lieux)

Klappe/
 flap/
 clapet

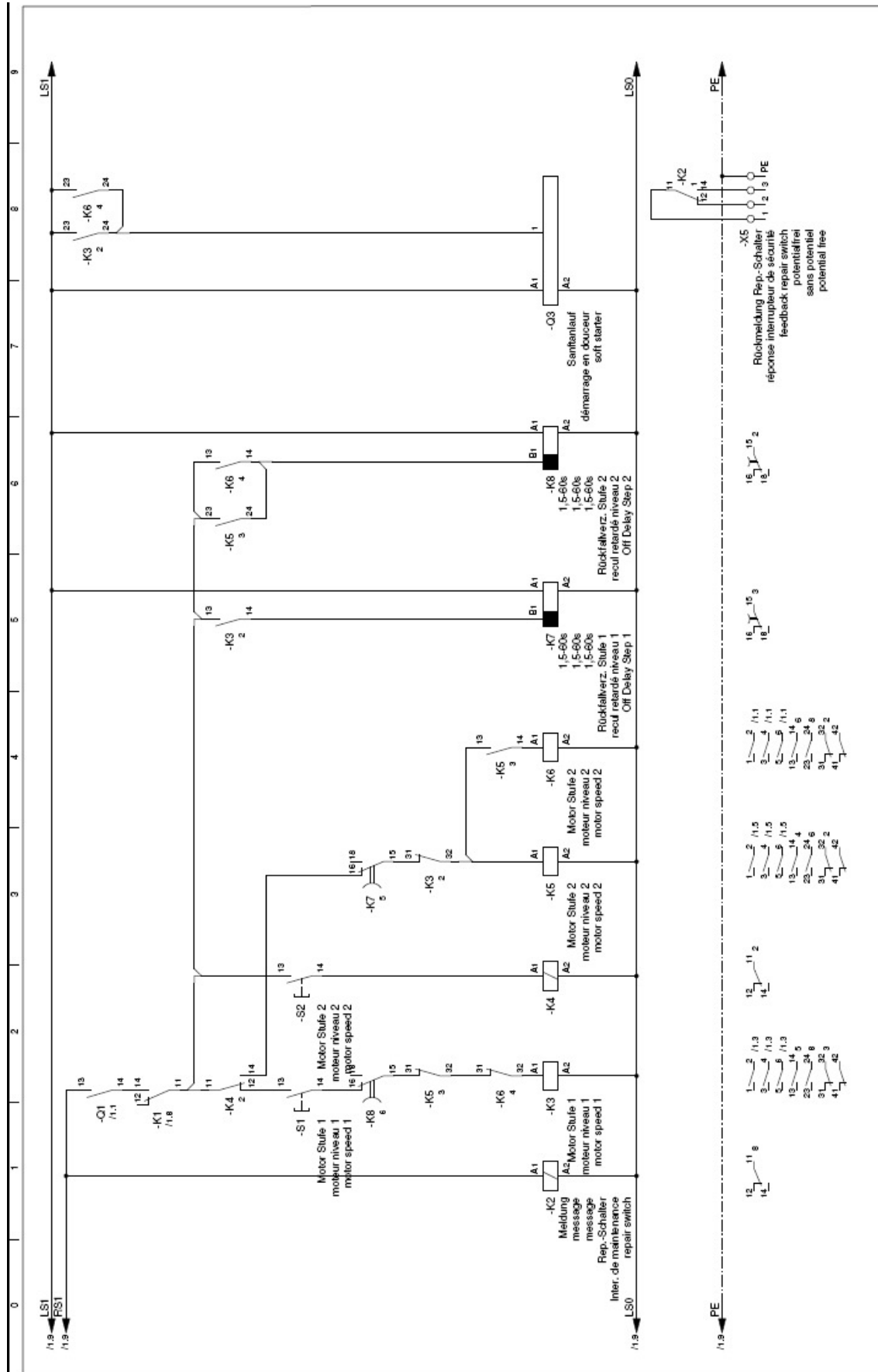



16. Circuit diagram (attachment 2)



17. Installation plan (attachment 3)