

Operating instructions Wetting Controller GHM pad

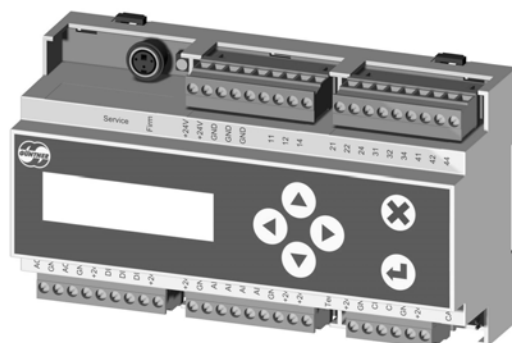

for the management and water volume control of condensers and drycoolers with hydropads

www.guentner.de

Contents

1	General notes.....	5
1.1	Safety instructions.....	5
1.2	Proper intended use.....	5
1.3	Transport and storage, copyright notice.....	6
1.4	Warranty and liability.....	6
1.5	Manufacturer and supplier address.....	7
1.6	EMC-compliant installation.....	7
2	Operating mode.....	8
3	Commissioning the wetting controller GHM pad.....	9
3.1	The initial commissioning procedure.....	10
4	Construction of the GHM pad.....	12
4.1	Remote controllers.....	13
4.1.1	Functional description.....	13
4.1.2	Installation / Operating conditions.....	16
4.1.3	Controller GRCpad.1.....	17
4.1.4	Connections.....	18
5	Display and operation.....	21
5.1	Info menu.....	21
5.2	Operation.....	22
5.3	Edit mode.....	23
5.4	Selection mode.....	24
5.5	Configuration.....	25
5.5.1	Configuration table.....	25
5.6	Potential-free signalling outputs.....	27
5.6.1	Digital output (11/12/14) (fault).....	27
5.6.2	Digital output (21/22/24) (warning).....	27
5.6.3	Digital output (31/32/34) (Wetting in operation).....	27
5.6.4	Digital output (41/42/44) (drain valve).....	27
5.7	Control inputs.....	28
5.7.1	Enabling of humidity controller.....	28
5.7.2	Differential pressure switch.....	29
5.7.3	water volume meter.....	29
5.8	Analogue inputs.....	30
5.8.1	Connecting a temperature sensor and humidity sensor to AI1/ AI2.....	30
5.9	Analogue outputs.....	31
5.10	Operating menu.....	32
5.10.1	Current values.....	33

5.10.1.1	External temperature.....	33
5.10.1.2	External air humidity.....	33
5.10.1.3	Fan speed.....	33
5.10.1.4	Water volume.....	34
5.10.1.5	Valve control value.....	34
5.10.1.6	Draining.....	34
5.10.1.7	Water flow.....	34
5.10.2	Status.....	35
5.10.2.1	Operating mode.....	35
5.10.2.2	Wetting ON/OFF/Frost protection.....	35
5.10.2.3	Status Release.....	36
5.10.2.4	Hardware and software versions.....	36
5.10.2.5	Wetting hours.....	36
5.10.2.6	Water meter.....	36
5.10.2.7	Efficiency mode.....	36
5.10.3	Parameters.....	37
5.10.3.1	Wetting.....	37
5.10.3.2	Draining.....	37
5.10.3.3	Efficiency mode.....	38
5.10.3.4	Geodata: height.....	38
5.10.4	Alarms.....	39
5.10.4.1	Alarm memory.....	39
5.10.5	Language.....	40
5.10.5.1	Language selection.....	40
5.10.6	Time.....	41
5.10.6.1	Time setting.....	41
5.10.7	Date.....	42
5.10.7.1	Set date.....	42
5.10.8	Manual mode.....	43
5.10.8.1	Manual mode ON / OFF /Valve setpoint / Draining.....	43
5.11	Service.....	44
5.11.1	Control parameters.....	45
5.11.1.1	Control parameters Kp, Ti.....	45
5.11.2	Air parameters.....	46
5.11.2.1	Airflow volume and air speed.....	46
5.11.3	Water parameters.....	46
5.11.3.1	Max. flow.....	46
5.11.3.2	Base value.....	46
5.11.3.3	Full load mode.....	47
5.11.3.3.1	Increment, delay, max. H2O supply.....	47
5.11.3.4	H2O offset.....	47
5.11.4	Drive parameters.....	47
5.11.4.1	Type of speed control: EC/FU/leading edge.....	48
5.11.4.2	Electric power.....	48

5.11.5	System parameters.....	49
5.11.5.1	Fault report.....	49
5.11.5.2	Matt ID.....	49
5.11.6	Operating mode.....	50
5.11.6.1	Operating mode setting.....	50
5.11.7	SI/IP selection.....	51
5.11.7.1	SI/IP units system.....	51
5.11.8	Factory setting.....	52
5.11.8.1	Control reset (factory setting).....	52
5.11.9	Delivery condition.....	53
5.11.9.1	Control reset (delivery condition).....	53
6	Faults and troubleshooting.....	54
6.1	General notes.....	54
7	Technical data.....	55
7.1	Dimensions and weight.....	55
8	Electrical properties of the components.....	56
9	Factory setting.....	58
10	Error messages and warnings on the GMM display.....	59
11	Troubleshooting tips.....	60
12	Index.....	61
13	Picture index.....	64
14	Table index.....	65

1 General notes

1.1 Safety instructions

In order to prevent serious physical injuries or major material damage, work on or with the equipment may be performed only by authorised persons with the appropriate training and qualifications who are familiar with the set-up, installation, commissioning and operation of electronic controllers. These persons must read the operating instructions carefully before installation and commissioning. In addition to the operating instructions and national regulations on accident prevention, recognised technical rules (safety and professional work under UVV, VBG, VDE etc.) must be followed.

Repairs to the device may only be made by the manufacturer or a repair centre authorised by the manufacturer.

UNAUTHORISED AND IMPROPER INTERVENTIONS WILL INVALIDATE THE WARRANTY!

The applicable national accident prevention regulations must be followed when working on controllers under voltage.

1.2 Proper intended use

The equipment is only intended for the purposes agreed in the order confirmation. Any other or additional use is not in accordance with its intended purpose. The manufacturer accepts no liability for any damage arising from unintended use. The intended use also includes compliance with the installation, operating and maintenance procedure described in these operating instructions. The technical data and the details of the terminal assignments can be found on the type plate and the instructions and must be followed.

Electronic equipment is not fundamentally failsafe! The user must therefore ensure that his system reverts to a safe condition in the event of failure of the equipment. The manufacturer accepts no responsibility for any damage to life and limb or to material goods and assets in the event of failure to comply with this provision and in the event of improper use.

The electrical installation must be performed in accordance with the relevant regulations (e.g. cable cross-section, fuses, earth conductor connection etc.). Additional information is included in the documentation. If the controller is used in a particular area of application, the requisite standards and regulations must be followed.

1.3 Transport and storage, copyright notice

The controllers are packaged appropriately for transport and may only be transported in their original packaging. Avoid any impacts and collisions. Unless otherwise noted on the packaging, the maximum stacking height is 4 packs. When you receive the equipment, check for any damage to the packaging or the controller.

Store the equipment in its original packaging and protected from the weather, and avoid extremes of heat and cold.

Subject to technical changes in the interests of further development. Therefore no claims may be derived from information, images and drawings; errors excepted!

All rights, including rights created by patent grant or other registration, are reserved.

These operating instructions are the copyright of

GÜNTNER AG & CO. KG

Fürstenfeldbruck

1.4 Warranty and liability

The current General Terms and Conditions of Güntner AG & Co. KG apply.

See homepage <http://www.guentner.de>

1.5 Manufacturer and supplier address

Should you have a problem with any of our equipment, or any questions, suggestions or special requests, simply contact

Güntner AG & Co. KG
Hans-Güntner-Strasse 2-6
D-82256 Fürstenfeldbruck, Germany

Service Telephone Germany:

0800 48368637

0800 GUENTNER

Service Telephone Worldwide:

+49 (0)8141 242-4810

Fax. +49 (0)8141 242-422

service@guentner.de

http://www.guentner.de

Copyright © 2011 Güntner AG & Co. KG

All rights, including rights of photomechanical reproduction and storage in electronic form, are reserved.

1.6 EMC-compliant installation

Controllers in the GHM pad series fulfil the requirements of EN 61000-6-2 as regards resistance to EMC interference and those of EN 61000-6-3 as regards emissions.

They also comply with standards IEC 61000 -4/-5/-6/-11 for grid-bound interference. In order to guarantee EM compatibility, the following points must be noted:

- All measurement and signalling lines must be connected via shielded cables.
- The shielding of measuring, signal and bus lines must be earthed *at one end* only.
- Suitable shielding and routing measures must be taken to ensure that mains cables and motor cables do not give rise to any interference in signal and control lines.

The GRCA controller module and any expansion modules are mounted on a top-hat rail and are attached to an earthed mounting panel in the switch cabinet. The electrical supply is connected with cable connectors.

ADVICE

If the equipment is installed in a switch cabinet, proper attention must be given to the temperature inside the cabinet. Güntner switch cabinets are provided with sufficient ventilation.

2 Operating mode

The controller calculates the water volume on the basis of the ambient conditions and the fans' speed. If the external temperature or the fans' speed are above the set start value for wetting (Parameters menu→ Wetting→ External temperature/Wetting ON), the wetting is released. If the speed or the external temperature fall below the set value, the wetting is deactivated (Parameters menu→ Wetting→ Wetting OFF, external temperature).

Partial load operation/Efficiency mode

If the speed is above the set value to start the wetting (Parameters menu→ Wetting→ Wetting ON) and below the threshold value of the full load mode, the controller works in partial load operation. In full load operation only as much water as the hydropads can evaporate is given off. If the efficiency mode is activated (Parameters menu→ Efficiency mode), Controller looks for the most cost-effective operating point between speed (power costs) and water volume (water costs). The costs can be set in the→ Efficiency mode→ Water costs, Power costs parameters menu. The Controller always searches here after a delay for the new most cost-effective operating point.

Full load operation

If the speed reaches the threshold value of the full load mode (Service menu→ Water parameters→ Full load mode), the increased water issue is started. If, after the set delay (Service menu→ Water parameters→ Delay) the speed is still above the set value of the full load mode, the water volume is increased incrementally. This happens up to a max. H₂O supply (Service menu → Water parameters→ Max. H₂O supply) with the prerequisite that the speed is still above the full load mode value.

If the speed falls below the threshold value again, the controller switches back to full load operation and the water volume is reduced incrementally.

Partial load operation without wetting

If the speed or the external temperature are above the set start value for the wetting, it remains inactive.

3 Commissioning the wetting controller GHM pad

The wetting controller communicates with the fan speed controller via 0#10V or CAN#BUS.

The wetting controller must be set up in accordance with the configuration of the heat exchanger and the fans.

When switched on the wetting controller automatically recognizes whether commissioning has already been carried out and, if it has, continues with normal operation.

If the GHM pad detects that this has not yet been done, it initiates the commissioning procedure. After the procedure is over all set parameters are saved. All values set up by the commissioning can also be viewed and changed individually later on in the menus.

3.1 The initial commissioning procedure

If it is recognized that commissioning has not yet taken place, the following values are interrogated and set up in accordance with the following flow chart.

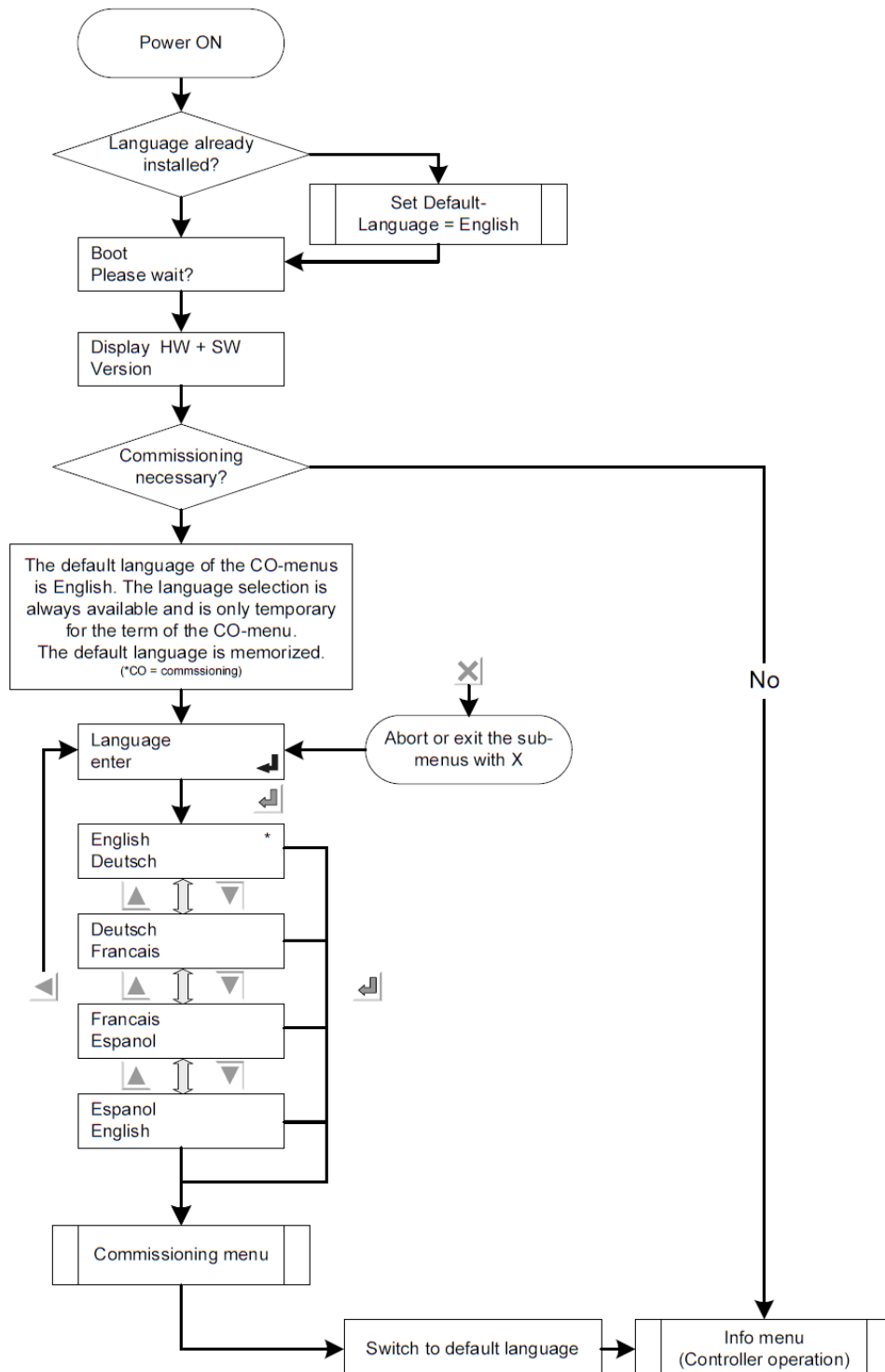

If it is recognized that commissioning is required, the commissioning menu is displayed.

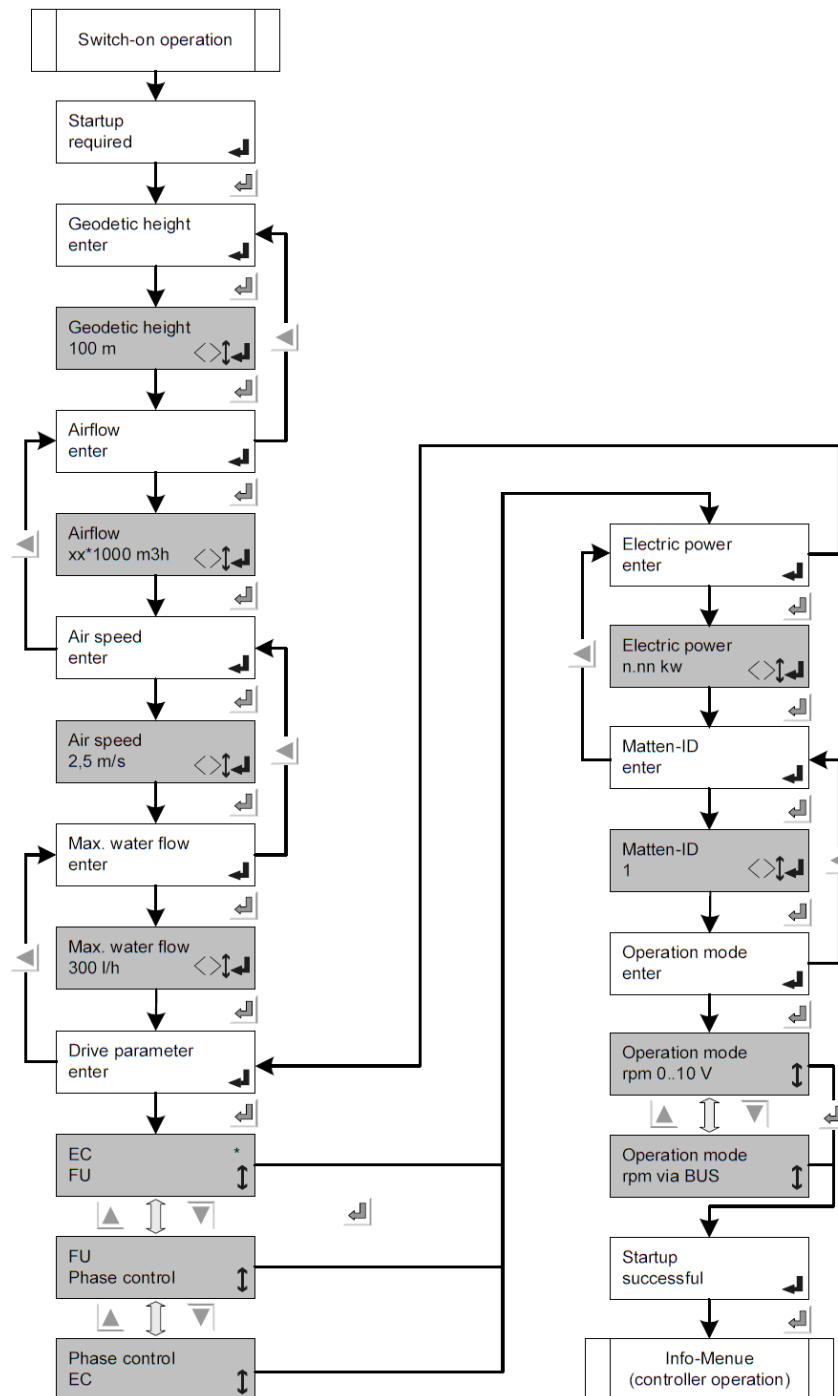

4 Construction of the GHM pad



Construction of the wetting controller GHM pad

The wetting controller consists of the following components:

1. Wetting controller (right)
2. Fan speed controller (left)

The wetting controller GHM pad can be combined with all current Guntner speed controllers (GMM EC, GMM sincon®, GDRD, GIRD).

The GHM pad can also be operated with other speed controllers, provided a 0-10V signal (the fans' control value) is available.

The control signal must be connected to the wetting controller on terminal AI4.

4.1 Remote controllers

4.1.1 Functional description

Functional description of GRCpad.1

The wetting system is used for increasing the capacity of heat exchangers at peak load times with high external temperatures and for more efficient heat dissipation with moderate ambient temperatures. The adiabatic evaporation of the water on the hydropads cools the air sucked in by the heat exchanger, which increases the heat exchanger's capacity.

The wetting controller GHM pad governs the regulation of the wetting process. The required water volume is calculated on the basis of the load state, the ambient temperature and the humidity. The GHM pad sets the appropriate water volume using the control valve. The system's frost protection is secured with automatic draining. The water supply to the unit must be protected separately against frost.

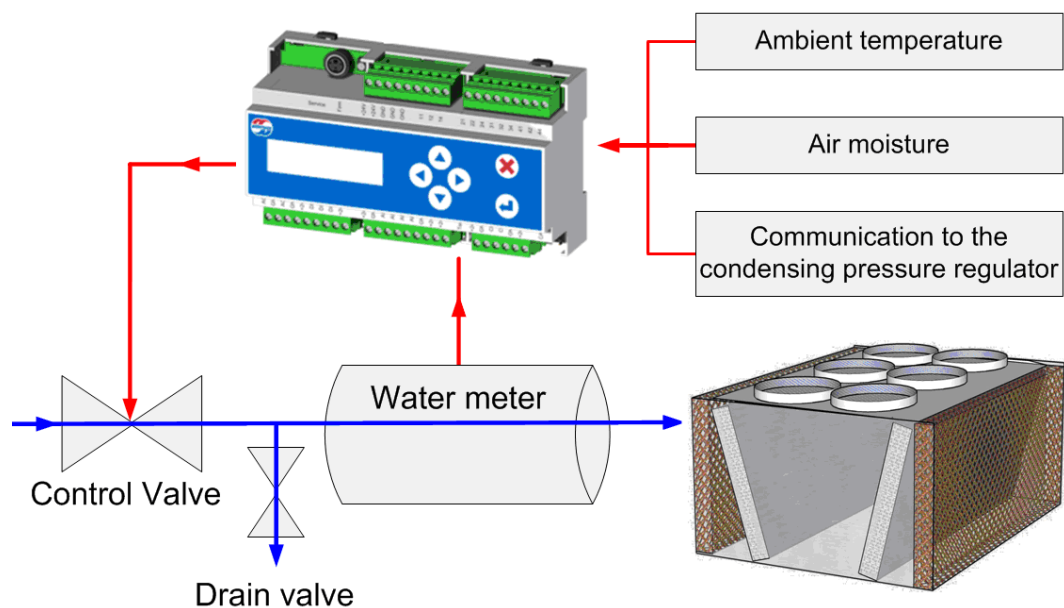

Short description of the wetting controller GHM pad

In order to operate the controller it must have a power supply and must be enabled via digital input DI1. If this is not enabled the process will not be regulated.

The digital inputs are designed as potential-free contacts that must be connected to +24V.

ADVICE

Please note that connecting the wrong voltage (e.g. 230V) may seriously damage the controller.

An analogue output is used to control a steady regulating valve that governs the amount of water on the wetting mats.

Relay outputs are used to control solenoid valves, system messages and alarms.

The CAN interface of the GRCpad.1 is an internal interface for communicating with other Guntner equipment.

The following communications modules are available for external bus connections: for Modbus (GCOMM.1, BAAN no. 5204182) or Profibus (GCMP.1, BAAN no. 5204543).

An accumulated annual temperature profile is shown below. As you see, the outlet temperature with drycoolers and the condensation temperature with condensers both depend on the ambient temperature.

The following explanations use only the term “condensation temperature”. Note that the same information applies to the “outlet temperature” of a drycooler.

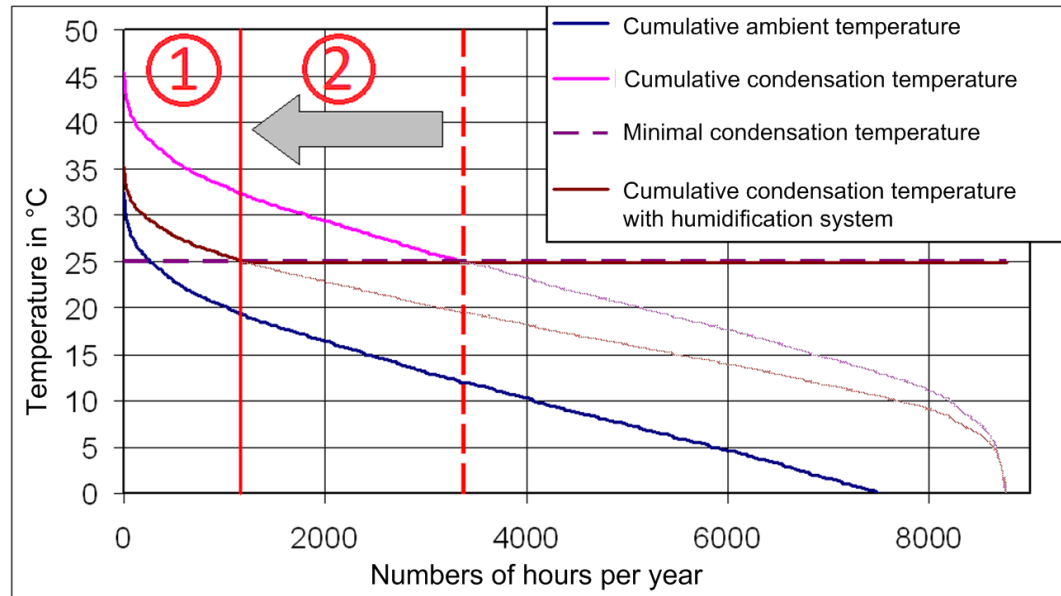

Accumulated annual temperature

A setpoint is set on the fans' speed controller for the minimum condensation temperature. If this setpoint is not reached because of high ambient temperatures, the fans run at full speed and the heat exchanger is in full load operation. The condensation temperature follows the ambient temperature in this operating state.

If the set minimum condensation temperature is reached, the fan speed is reduced to prevent any further reduction of the condensation temperature. The cooling of the air at the HydroPads increases the capacity of the heat exchanger. The additional wetting reduces the condensation temperature, which displaces the demarcation between full load operation (indicated by 1 in the diagram) and partial load operation (2). The dotted red line is the demarcation between full load operation and partial load operation in dry operating mode. The continuous line separates full load operation from partial load operation when wetting is also active. The controller distinguishes between three operating modes.

1) Full load operation:

- The fans run at full speed.
- The minimum condensation temperature is not reached.

The water volume can be increased in full load operation to achieve higher air cooling.

2) Partial load operation without efficiency mode:

- The fans are in controlled operation.
- The minimum condensation temperature is reached.

The wetting controller calculates the required water volume according to the ambient conditions so that, so far as possible, 100% of the supplied water will evaporate.

3) Partial load operation with efficiency mode:

- The fans are in controlled operation.
- The minimum condensation temperature is reached.

The wetting controller measures the water volume so as to minimise the total cost for fan drive and water. The controller calculates the most cost-effective operation on the basis of the entered water and power costs. The GHM pad calculates whether it is more cost-effective to dissipate the heat by evaporation cooling or by convection.

The controller is in full load mode or partial load mode, depending on whether the evaporation setpoint was reached or not. Efficiency mode for partial load operation can be activated in the parameters of the controller.

4.1.2 Installation / Operating conditions

Installation / Operating conditions GRCpad.1

- The module is designed for mounting on a top-hat rail.
- All measurement and signalling lines must be connected via shielded cables.
- The shielding of measuring, signal and bus lines must be earthed at one end only.
- Suitable shielding and routing measures must be taken to ensure that mains cables and motor cables do not give rise to any interference in signal and control lines.
- Temperature:
Storage Transport: #20°C ... +70°C
Operation: #20°C ... +65°C
- Protection rating: IP 20
- Recommended cables: Belden 9841, Lapp 2170203, Lapp 2170803, Helukabel 81910

4.1.3 Controller GRCpad.1

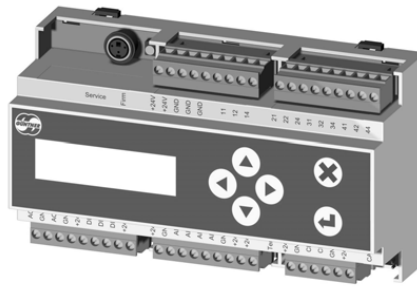

Controller GRCpad.1

Depending on the ambient conditions and speed of the fans the the water volume is controlled by the controller.

The unit is controlled by means of menus using a 2-line display and an input keyboard.

4.1.4 Connections

Connections GRCpad.1

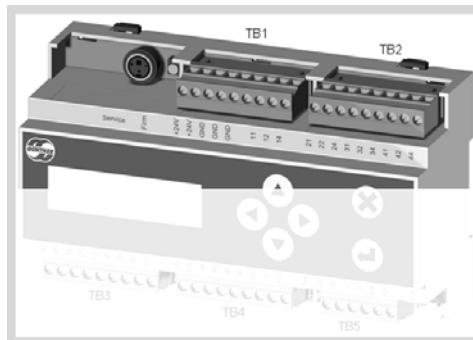

Upper row of connections			
	Name	Description	
	Service	Service plug only for use by service personnel	
	Firm	Pushbutton only for use by service personnel	
TB1	+24V	External feed for power supply	
	+24V		
	GND	Contact ground for external power feed	
	GND		
	GND		
		Terminal not connected	
	11		
	12		
	14		
TB2	21		
	22		
	24		
	31		
	32		
	34		
	41		
	42		
	44		

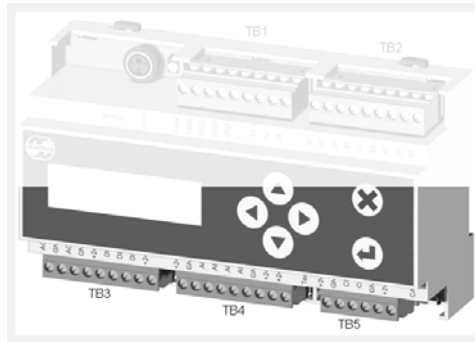

Lower row of connections		
	Name	Description
TB3	A01	Analogue output 1, 0#10V
	GND	Ground
	A02	Analogue output 2, 0#10V
	GND	Ground
	+24V	Voltage +24V
	DI1	Digital input +24V
	DI2	Digital input +24V,
	DI3	Digital input +24V
	+24V	Voltage +24V
TB4	+24V	Voltage +24V
	GND	Ground
	AI1	Analogue output 4#20mA
	AI2	Analogue input 4-20mA or for temperature sensor GTF must be configured in the software
	AI3	Analogue input for temperature sensor GTF
	AI4	Analogue input 0#10V
	GND	Ground
	+24V	Voltage +24V
	+24V	
	Term	DIP switch for CAN bus termination (120Ω) / ON = termination activated
TB5	+24V	Voltage +24V
	GND	Ground
	CH	CAN high signal
	CL	CAN low signal

Lower row of connections		
	GND	Ground
	+24V	Voltage +24V
	CAN	CAN bus plug including power supply

*TB: Terminal block

5 Display and operation

Information are shown on a two-line display. The controller is operated via a membrane keyboard.

5.1 Info menu

This menu is the controller's standard interface. The information on the various operating states is displayed here. The higher priority information appears on the display.

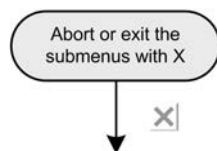

Pressing the down arrow key takes you to the basic menu. Press the X key to go back to the info menu.

Fan speed: 50%
System off

The wetting is OFF, as the current speed is below the set start value.

Outside: 21°C
System off

The wetting is OFF, as the current temperature is below the set start value.

Outside: -10,5°C
Frost protect

The frost protection is active, as the current temperature is below the set drain start value.

Contact DI1
error

There is no release, as this is not released via the DI1 input.
Note: With inactive release the wetting is not released. The input is bridged ex factory.

Temp.- sensor
AI1 error

Temperature sensor error on AI1. The sensor is defective or the signal is outside the measurement range.

Humidity sensor
AI2 error

Humidity sensor error on AI2. The sensor is defective or the signal is outside the measurement range.

U > 12V
AI4 error

Voltage on input AI4 is too high, but wetting can continue.

Hydraulics NOK
H2O: 50,8 l/h

The water valve is defective, tube is dirty or the water pressure is too low.

Air supply NOK

Dirt monitoring was triggered on the hydropads, differential pressure gauge has detected dirt.

BUS-Master NOK

Connection to BUS master lost.

Humidificat on H2O: 50,8l/h	Wetting is active. The current water consumption is shown in l/h.
Manual mode Active!	Manual mode is active and shown here.
Water threshold Not reached	Wetting is not active, as the calculated water volume does not exceed the base value.

5.2 Operation



Cancel and return to INFO menu



Enter key for function selection; change to EDIT mode and value acceptance



Right arrow for moving to the next menu level



Left arrow for moving to the previous menu level



Left arrow for scrolling through the menu level

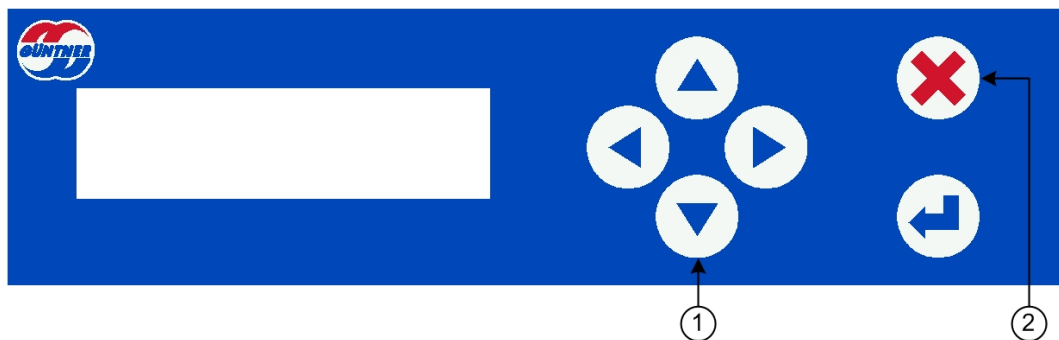

1. Use this key to move from the **"INFO"** menu to the **Operating menu**
2. Use this key to return to the **"INFO"** menu at any time

5.3 Edit mode

This mode is required to change values (control values, for example).



Select menu option you want
(top line)

```
Humidification ON
Humidification OFF
```



Change to menu option

```
Humidification ON <
rpm > 60%
```



Change to writing mode
(cursor flashes)

```
Humidification ON <
rpm > 60%
```

```
Humidification ON <
rpm > 60%
```



Decimal point selection
(cursor flashes)

```
Humidification ON <
rpm > _0,0%
```

```
Humidification ON <
rpm > 60%
```



Change value

```
Humidification ON <
rpm > 65%
```



New value acceptance

```
Humidification ON <
rpm > 65%
```

5.4 Selection mode

This mode is required to select functions (language, for example).



Select menu option you want
("Language", for example, top line)

Language
Time



Change to the menu option
→ The function/language currently set
is marked with an *asterisk*.

English
Deutsch *



Set target language by scrolling to the
top line
→ selected function/language in top line

⋮
English
Deutsch ⬆
⬆ ⬆
Deutsch *
Francais ⬆
⬆ ⬆
Francais
Espagnol ⬆
⬆ ⬆
Espagnol
English ⬆
⋮



Accept function/language.
→ selected language is marked with an
asterisk.

Deutsch
Francais *

5.5 Configuration

The GHM pad is configured with an appropriate number of potential-free contacts. Their assignments will differ depending on the configuration.

5.5.1 Configuration table

GRCpad.1 **input must be connected with GMM:**

	I/O	Signal	Position
GRCpad.1	DI1	24V	Enable
	DI2	24V	Differential pressure switch
	DI3	24V	Pulse input from water flow meter
	AI1	4..20mA	Temperature sensor 4..20 mA (#35...+75°C) **
	AI2	4..20mA/KTY	Humidity sensor 4..20 mA (0...100% rel.hum.)
	AI3	KTY	No function
	AI4	0..10V	No function
	AO1	0..10V	Control valve
	AO2	0..10V	No function
	DO1	Relay	Fault
	DO2	Relay	Warning
	DO3	Relay	System message Wetting is active
	DO4	Relay	Draining valve
CAN BUS			Fan setting 0..100%

Table: Configuration table GRCpad.1 **input must be connected with checks**

GRCpad.1 **None GMM:**

	I/O	Signal	Position
GRCpad.1	DI1	24V	Enable
	DI2	24V	Differential pressure switch
	DI3	24V	Pulse input from water flow meter
	AI1	4..20mA	Temperature sensor 4..20 mA (#35...+75°C) **
	AI2	4..20mA/KTY	Humidity sensor 4..20 mA (0...100% rel.hum.)
	AI3	KTY	No function
	AI4	0..10V	Fan setting 0..100%
	AO1	0..10V	Control valve
	AO2	0..10V	No function
	DO1	Relay	Fault
	DO2	Relay	Warning

Table: Configuration table GRCpad.1 **None checks**

	I/O	Signal	Position
	D03	Relay	System message Wetting is active
	D04	Relay	Draining valve
CAN BUS			No function

Table: Configuration table GRCpad.1 **None** checks

** The measuring range of the temperature sensor must be set up accordingly. You will find the necessary information in the corresponding data sheet.

If you use the combined temperature and humidity sensor AFTF#I (BAAN 5204798) you will need to set DIP switches DIP 1 and DIP 2 to ON.

5.6 Potential-free signalling outputs

For safety reasons, the potential-free signal outputs (two-way contacts) are designed in such a way that the corresponding signal relay is deactivated when the event is triggered, i.e. the opener of the corresponding two-way contact closes. This has the effect that a malfunction is also signalled if the wetting controller loses power due to a fault. The load on all signal outputs must not exceed 250V/1A.

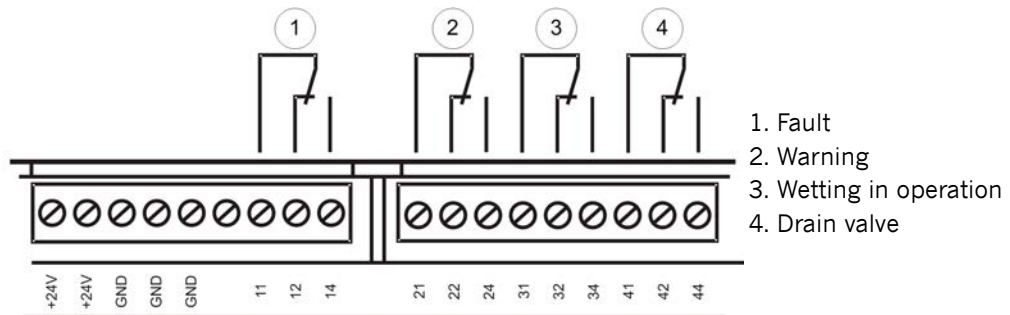

5.6.1 Digital output (11/12/14) (fault)

The message on the contact 11/12/14 is a fault, which endangers the wetting system.

A defective temperature sensor could not start the frost drain, which would result in the water system freezing.

Contact 11/12 is closed in alarm status.

Alarms, see [Error messages and warnings on the GMM display, Page 59](#)

5.6.2 Digital output (21/22/24) (warning)

Signals on contact 21/22/24 are warnings that do not result in the complete failure of the wetting system. These are warnings that the is impaired.

5.6.3 Digital output (31/32/34) (Wetting in operation)

The two-way contact (31/34) is closed as soon as a water flow is provided.

5.6.4 Digital output (41/42/44) (drain valve)

The two-way contact (41/44) is closed when draining is inactive.
The draining valve is opened without power.

5.7 Control inputs

The control inputs are designed as a **low-voltage connection** and are connected via a potential-free contact (relay, contactor contact, switch etc.). The potential-free contact must be switched between the terminals **+24V** and the **DI1** or **DI2** or **DI3** control input. The function is activated when the contact is closed.

5.7.1 Enabling of humidity controller

Terminal **DI1(enable)** is used to enable wetting. If this enable is not switched, wetting will be disabled.

*If it is not to be enabled externally, terminal **DI1** must be jumpered.*

This enabling jumper is always installed in the factory.

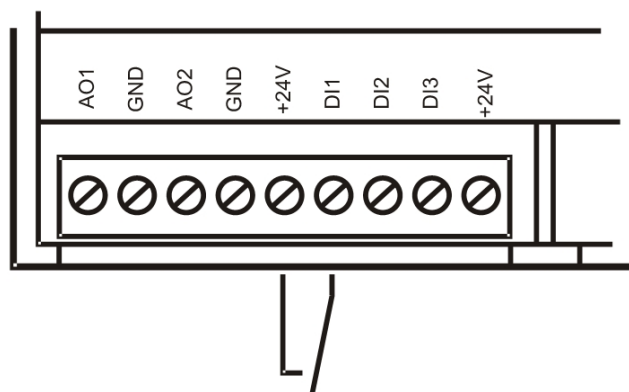

Connection of external enable contact +24V – DI1

ADVICE

Under no circumstances may the controller be disabled by interrupting the supply voltage! Continuously switching the supply voltage can damage the controller, and such damage is not covered by the warranty!

Enable is not required in “Manual mode”.

See [Manual mode, Page 43](#)

5.7.2 Differential pressure switch

The differential pressure switch is connected to the wetting controller via the "DI2" terminal. If the hydropads and the heat exchanger are dirty, the air flow pressure loss increases and the system goes to alert, provided the pressure does not fall below the value set on the differential pressure switch during the configured testing period (Service menu → System parameters → Fault report → Air → Testing period). The configured testing period prevents faults being caused by brief air turbulences. The differential pressure switch is set in the factory when the unit is commissioned. If the input for the pressure switch is activated, then the "Air supply NOK" alarm is issued.

If the input is not switched again, the alarm continues to be displayed and is listed in the alarm history.

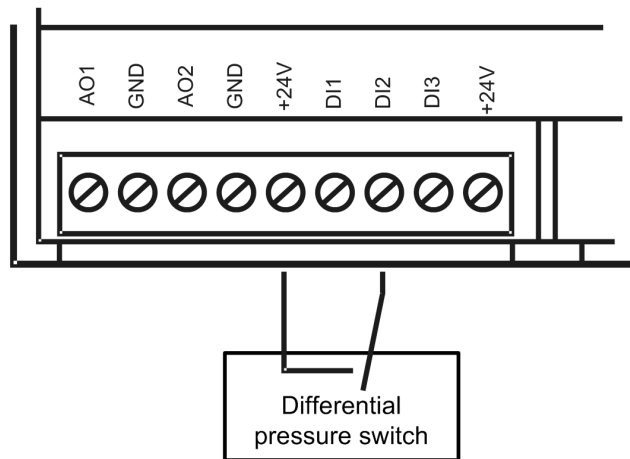

Differential pressure switch connection

5.7.3 water volume meter

A pulse is sent from the water flow meter via the "DI3" terminal to the .

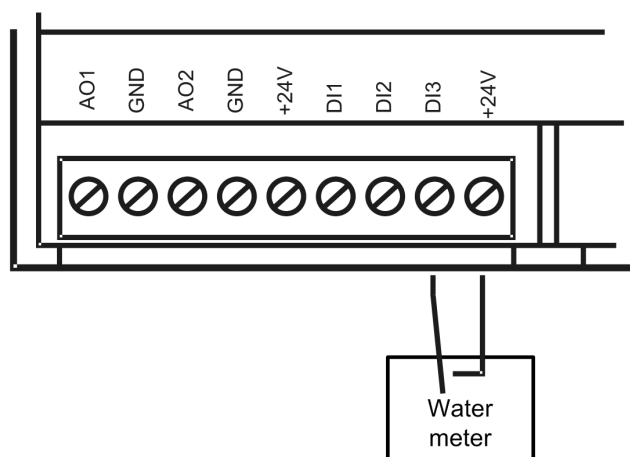

Water flow meter connection

5.8 Analogue inputs

The wetting controller has four sensor inputs

Input AI1	Current input	4-20mA
Input AI2		4-20mA
Input AI3	empty	
Input AI4	Voltage source	0-10V DC

The various ways of using inputs and how to connect them in each case are described below.

5.8.1 Connecting a temperature sensor and humidity sensor to AI1/AI2

Two sensors are connected.

- +24 V = Common supply voltage
- AI1 = 4-20 mA signal from temperature sensor
- AI2 = 4-20 mA signal from humidity sensor
- GND = Earth (negative)

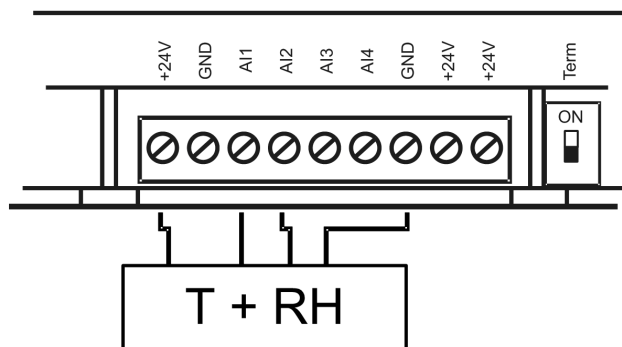

Temperature sensor + humidity sensor connection

5.9 Analogue outputs

The control unit has 2 analogue outputs with 0..10V output voltage.

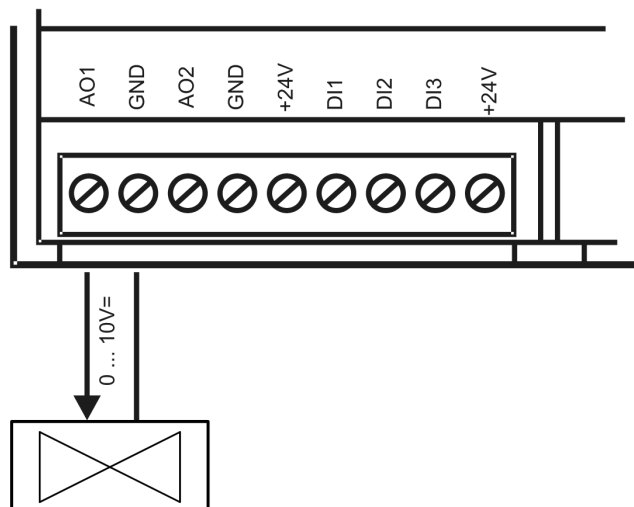

Analogue outputs

Output **AO1** issues the control signal (0..100%) scaled to 0..10V (for the control valve).

Output **AO2** is not seized.

5.10 Operating menu

Structure of basic menu

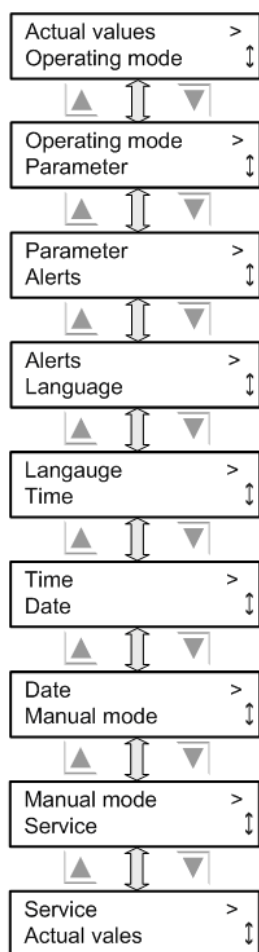

5.10.1 Current values

The actual input signals and control values are shown here.

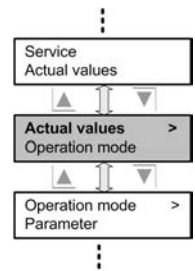

5.10.1.1 External temperature

The actual external temperature is shown.

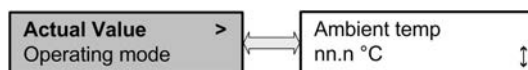

5.10.1.2 External air humidity

The actual external air humidity is shown.

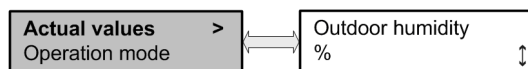

5.10.1.3 Fan speed

The current fan speed is shown. This is shown as a percentage of the maximum speed.

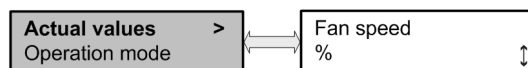

5.10.1.4 Water volume

The currently calculated water volume is shown in l/h.

The water volume is calculated from the ambient conditions.

Full load mode: The calculated water volume is multiplied with a factor resulting from the increment, delay and max. H2O supply. If the threshold value is reached, the water volume is increased incrementally with the set delay, up to the maximum value set in the Service menu.

Partial load operation with efficiency mode: The water volume is calculated to determine costs. The most cost-effective operating point between speed (power costs) and water volume (water costs) is determined here.

Partial load operation without efficiency mode: Only as much water as the hydropads can evaporate is applied.

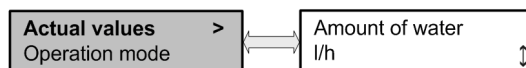

5.10.1.5 Valve control value

The water valve control value (0-10V) is displayed.

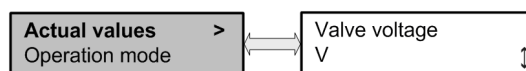

5.10.1.6 Draining

Whether draining is active or inactive is displayed.

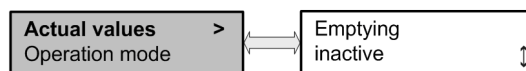

5.10.1.7 Water flow

The water meter shows the recorded water flow.

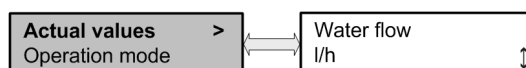

5.10.2 Status

The operating statuses, efficiency mode settings, operating hours, water volume and software/hardware versions are displayed here.

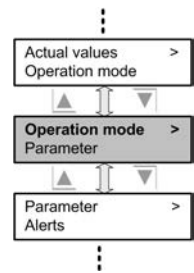

5.10.2.1 Operating mode

This shows the current operating mode in which the GMM and the wetting controller are communicating..

0-10V or BUS

If manual mode is active, its operating status is displayed.



5.10.2.2 Wetting ON/OFF/Frost protection

The operating status that the system is in is displayed here. The corresponding actual value is also shown.

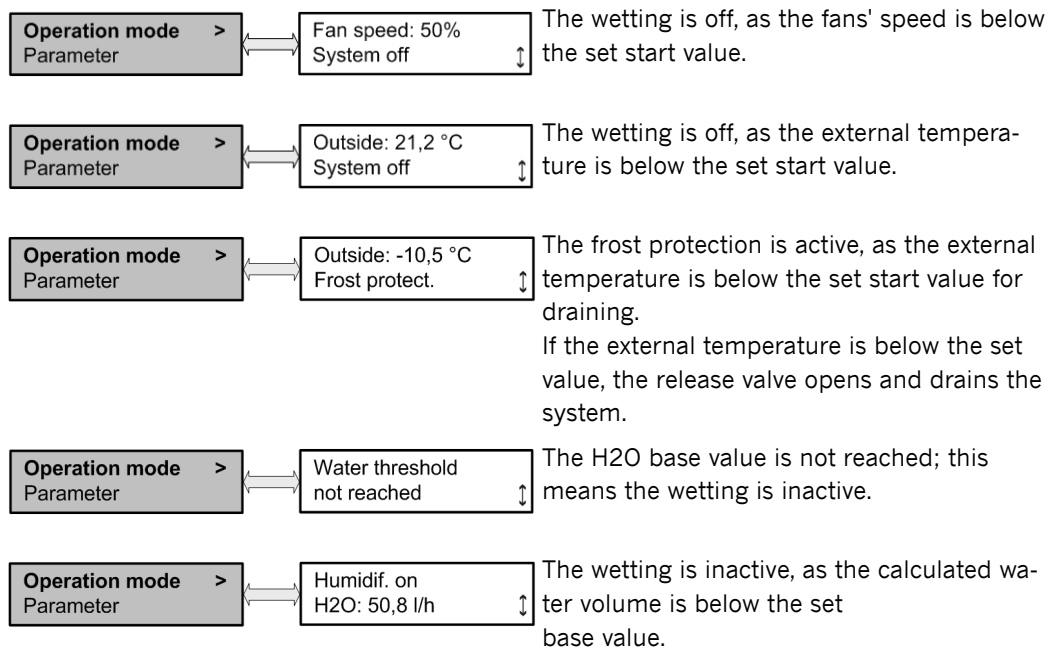

5.10.2.3 Status Release

Controller on connection **D1** enabled **OK** or not **None**"

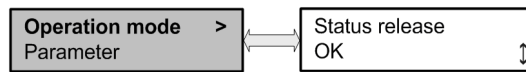

5.10.2.4 Hardware and software versions

This shows information about the current hardware and software versions of the wetting controller.

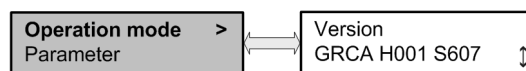

5.10.2.5 Wetting hours

The wetting operation hours are shown here.

(→Only displayed for new commissioning)

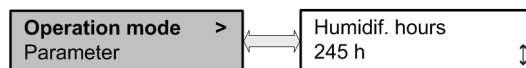

5.10.2.6 Water meter

The water meter's status is displayed here.

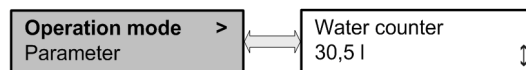

5.10.2.7 Efficiency mode

If efficiency mode is active it is displayed here, as are the power and water costs that were set in the Parameters menu (see [Parameters, Page 37](#)).

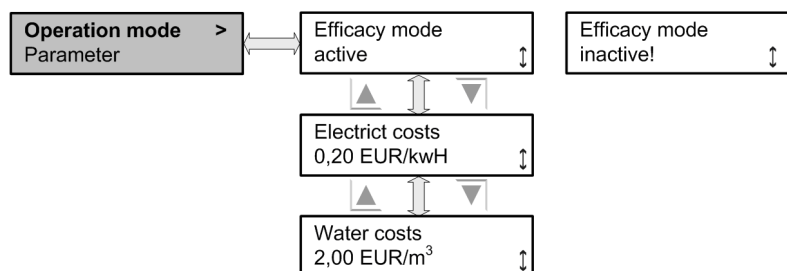

5.10.3 Parameters

The parameters are configured in this menu.

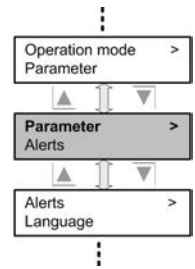

5.10.3.1 Wetting

Wetting ON/external temperature

The wetting starts if the speed and temperature are exceeded.

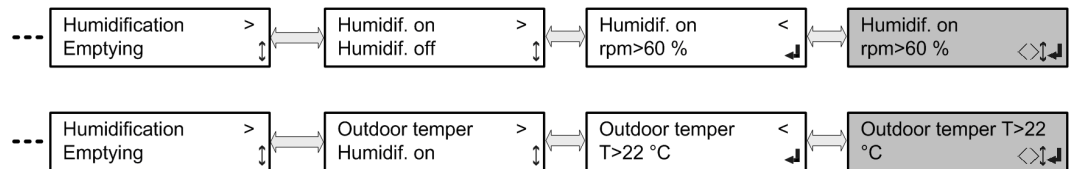

Wetting OFF

The wetting switches off when the speed falls below the set speed.

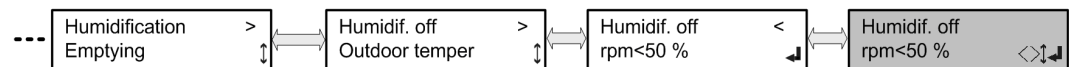

5.10.3.2 Draining

Standstill time

The draining valve is automatically opened and the system drained after the set standstill time.

Note: Legionella bacteria can form after lengthier periods of water standing still in the system.

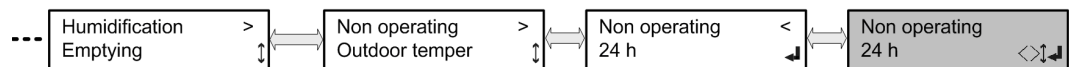

External temperature

If the temperature falls below the set temperature the system is drained to prevent freezing.

Note: The water supply to the system must be protected separately against frost.

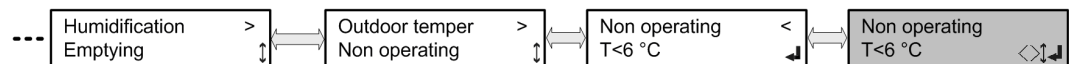

5.10.3.3 Efficiency mode

ON/OFF

If the efficiency mode is activated, the calculates the most cost-effective combination of water volume and fan speed in every operating situation, so that the average setpoint set in the speed controller is reached.

Note: The power and water costs must be entered in the Costs menu for the calculation.

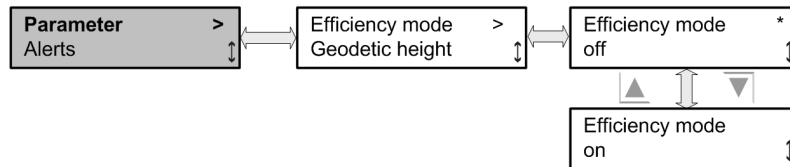

Water costs

If the efficiency mode is activated, the water costs are required for the cost efficiency calculation.

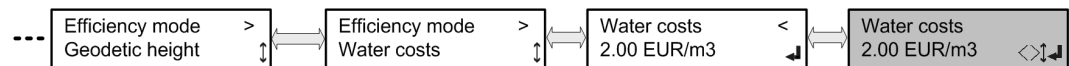

Power costs

If the efficiency mode is activated, the costs incurred per kilowatt hour consumed are required for the cost efficiency calculation.

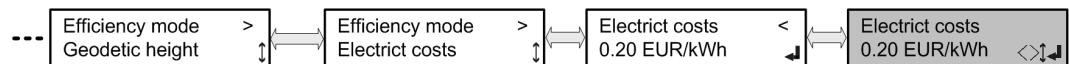

5.10.3.4 Geodata: height

The set-up height geodata must be entered for the water volume calculation, as the air density falls as height increases.

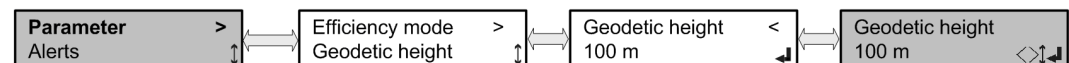

5.10.4 Alarms

The last 85 alarms can be called up here.

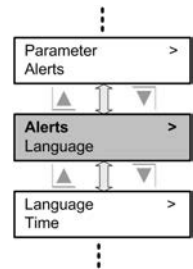

5.10.4.1 Alarm memory

The wetting controller has an alarm memory that can accommodate up to 85 priority 1 and 2 messages (errors and warnings) stored consecutively (cyclically). These error messages consist of the fault and the time stamp, i.e. the date and time, at which the fault occurred. For a list of error messages and warnings see [Error messages and warnings on the GMM display, Page 59](#).

When the alarm memory is selected, the display shows the last fault that occurred. Use the “down” arrow key to display older faults.

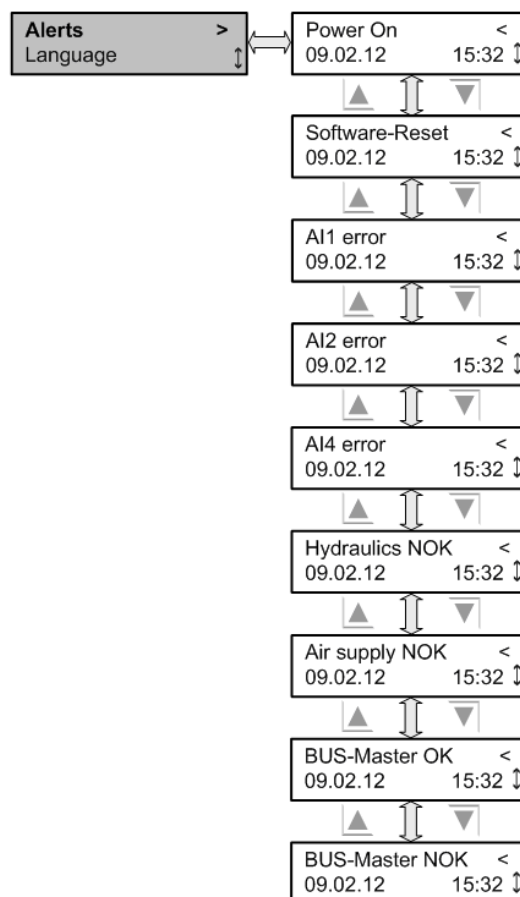

5.10.5 Language

The menu language can be selected here.

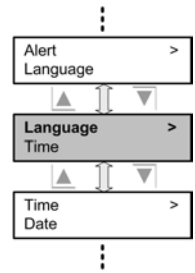

5.10.5.1 Language selection

In the Language selection menu you can select from four languages. The selected language is marked with an *asterisk*.

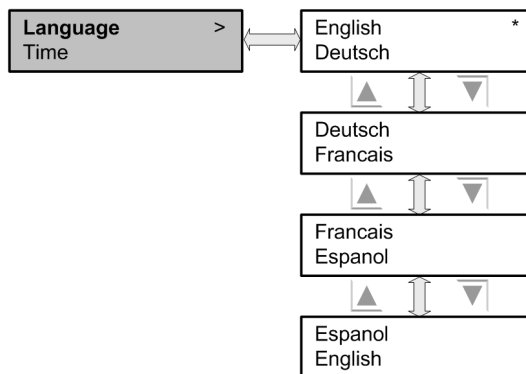

5.10.6 Time

The time can be selected here.

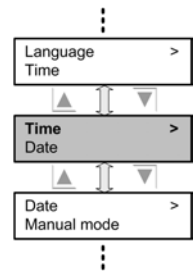

5.10.6.1 Time setting

The set time is displayed and changed where required in the 24-hour clock.

This time is used to enter the alarm times in the alarm memory and for all timer functions.

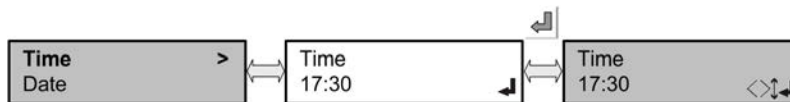

5.10.7 Date

The date can be set here.

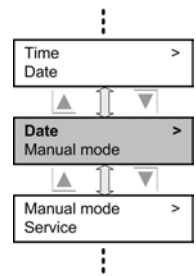

5.10.7.1 Set date

The date is used to enter the alarm times in the alarm memory and for all timer functions

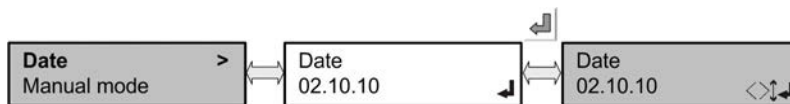

5.10.8 Manual mode

Manual mode is used to operate the system's water inlet valve and drainage valve by hand.

Manual mode does not depend on DI1 enabling.

Manual mode has the highest priority and switches all other control types off.

The prerequisite for switching on the manual mode is the set external temperature. This must be above the frost temperature, as otherwise the manual mode cannot be switched on. Wetting is not permitted in the manual mode without recording the external temperature.

The fact that manual mode is active is recorded permanently. In other words, it will still be active after you have switched the system off and back on.

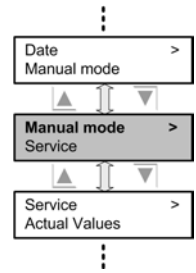

5.10.8.1 Manual mode ON / OFF /Valve setpoint / Draining

When manual mode is activated, the water valve opening (0..10V) can be changed manually in the valve control value menu. This can be activated in the draining menu.

The * indicates whether manual mode ON or OFF is active.

Manual mode ON / OFF

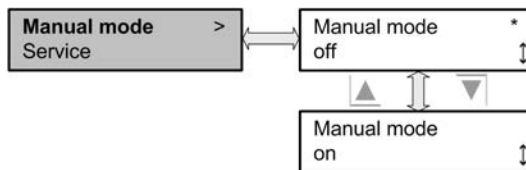

Manual mode – valve control value/draining

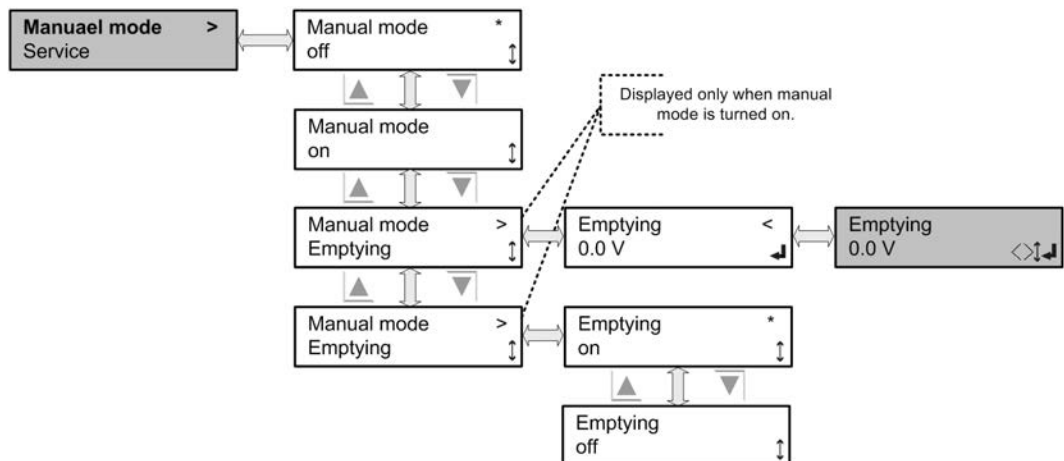

5.11 Service

The Service menu is accessible only with the correct password, which is the first thing you are asked for. The password is **3795**.

Once the password has been accepted, the Service menu appears.

The password is valid for 15 minutes and will not be requested again during this time.

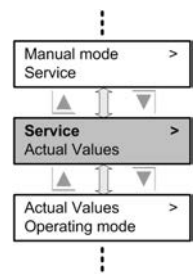
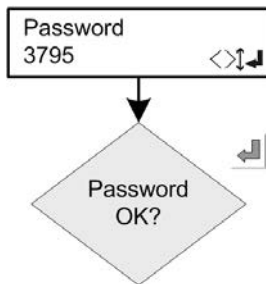

Service menu set-up

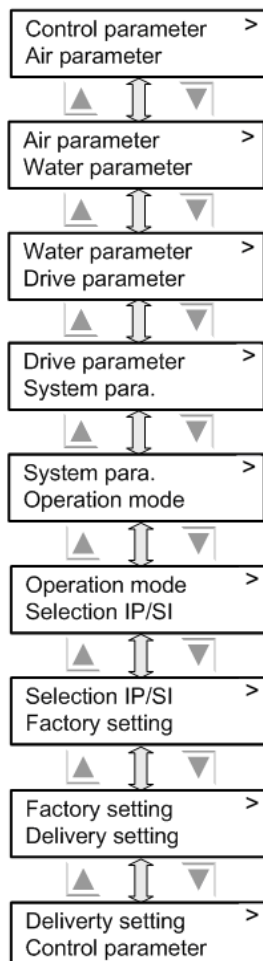

5.11.1 Control parameters

In this menu you configure the control parameters of the digital PID controller (proportional, integral, derivative controller).

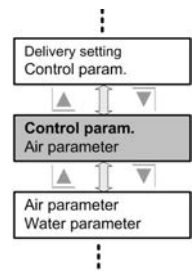

5.11.1.1 Control parameters Kp, Ti

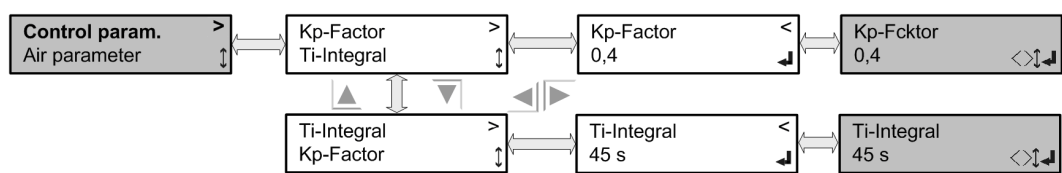

The Kp factor can be entered in a range from 0.1 to 10.0 to one decimal place. The Kp factor specifies the control amplification. It is the proportion of the control path following the input signal.

The Ti reset time changes the control value in the set time by the value specified by the proportional factor.

The max. flow in the water parameters sub-menu is required as a control parameter.

Example: With a max. flow of 1000 l/h a deviation of 100 l/h is equal to a control deviation of 10%. With an unchanged control deviation of 10% and $K_p = 0.4$ the Ti control signal = 45s is increased by 4%.

5.11.2 Air parameters

The air parameters are configured in this menu.

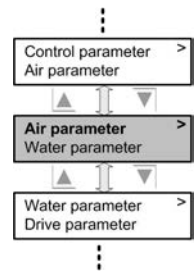

5.11.2.1 Airflow volume and air speed

The maximum airflow volume and the maximum air speed must be entered to calculate the required water volume.

Note: You will find this data on the GPC unit construction sheet.

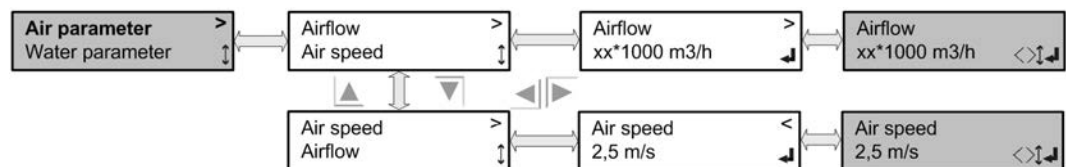

5.11.3 Water parameters

The water parameters are configured in this menu.

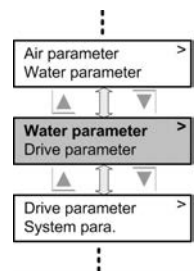

5.11.3.1 Max. flow

The maximum flow must be set so that the control deviation and the control variable of the water valve can be calculated.

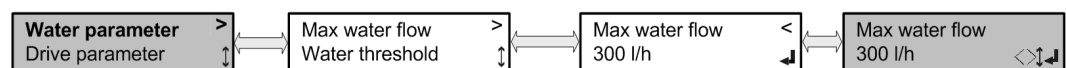

5.11.3.2 Base value

The wetting is only released when the calculated water volume is above the base value.

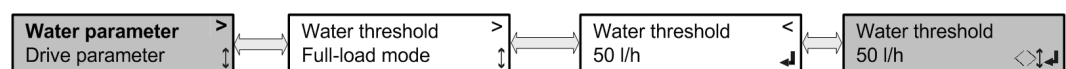

5.11.3.3 Full load mode

The full load mode is activated at this set limit. If the fans' speed is below the set limit value, the efficiency mode is active, provided it was switched on in the Parameters → Efficiency mode menu. If the efficiency mode is switched off, the wetting is performed with the calculated water volume, but without any costs consideration.

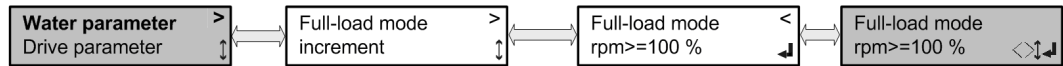

5.11.3.3.1 Increment, delay, max. H2O supply

If the calculated water volume is not sufficient in the full load operation, the water volume is increased incrementally with a delay up to the maximum water issue rate. By increasing the water issue rate, a part of the water flows unevaporated, but this means that in full load a higher wetting capacity of some 10% can be achieved.

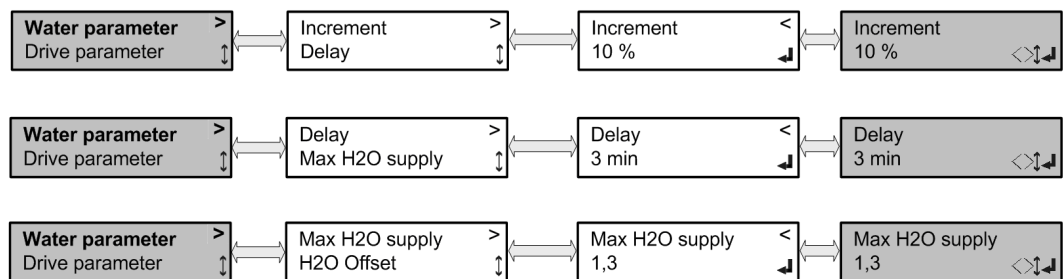

5.11.3.4 H2O offset

The H2O offset is a correction factor on the water volume calculated by the controller. With a factor of >1 the calculated water volume can be increased, and reduced with a factor of <1.

Note: The water volume is dosed in the efficiency mode according to cost consideration points. Depending on the type of system and operating situation, it is possible that the water admission flow of the hydropad is very low, and it is also possible that the water will drain off unevaporated.

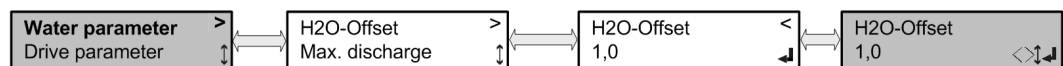

5.11.4 Drive parameters

The drive parameters are configured in this menu.

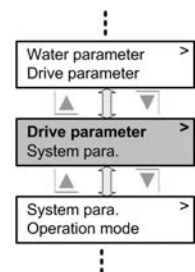

5.11.4.1 Type of speed control: EC/FU/leading edge

The type of speed control must be entered for the efficiency calculation.

- EC fans → EC
- AC fans → FU GMM sincon
- GMM f-drive
- GDRD leading edge

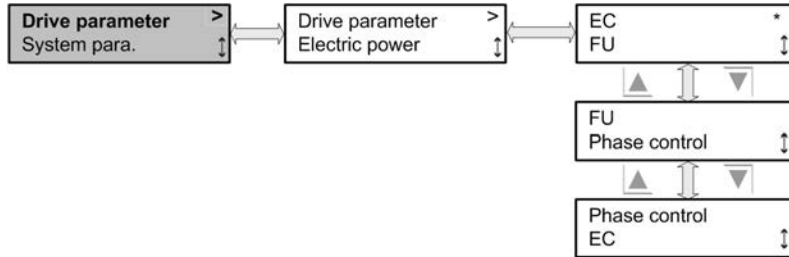

5.11.4.2 Electric power

The entire nominal power of the fans must be entered for the costs calculation.

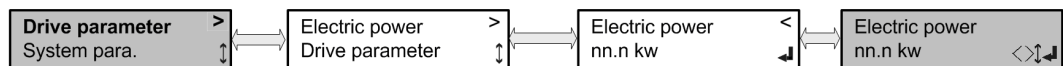

5.11.5 System parameters

The system parameters are configured in this menu.

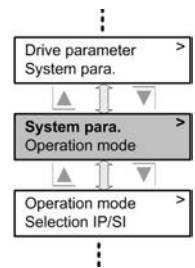

5.11.5.1 Fault report

Water fault report:

The max. deviation and the testing period are set here.

If the control deviation is above the set max. deviation for the entire testing period, a fault report is made.

Setpoint - actual value > max. deviation → Fault

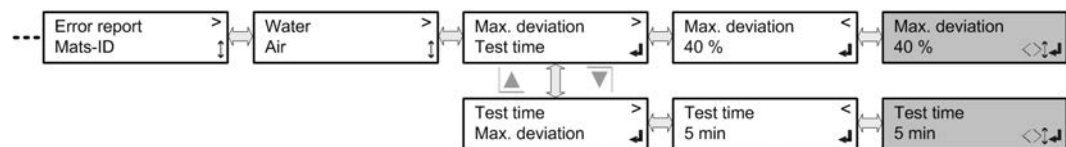

Air fault report:

The max. pressure loss over the hydropads and heat exchanger coil is set on the differential pressure switch. If the pressure loss is above the max. permissible pressure loss for the entire testing period, there is a fault report.

Note: Take pressure loss from the GPC. If a fault occurs it is recommended you clean the heat exchanger and the hydropads.



5.11.5.2 Matt ID

The matt ID is set here.

1 = Jäggi

2 = Güntner

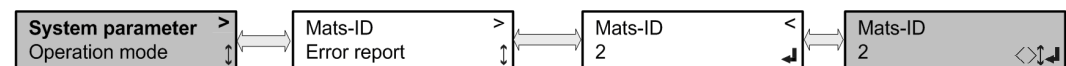

5.11.6 Operating mode

The operating mode can be set in this menu.

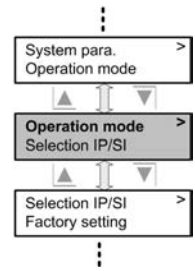

5.11.6.1 Operating mode setting

You can select between "0..10V" and "via BUS".
The active operating mode is marked with a *.

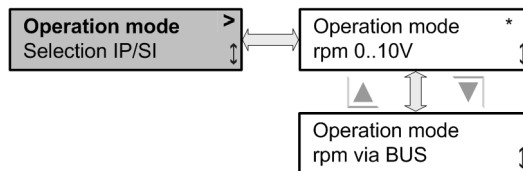

5.11.7 SI/IP selection

The units system can be selected here.

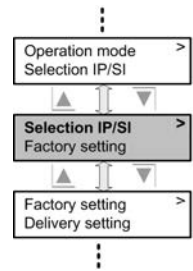

5.11.7.1 SI/IP units system

Unit selection for temperature and relative humidity.

International units →

SI (Système international d'unités)

Anglo-American units →

IP (Imperial System)

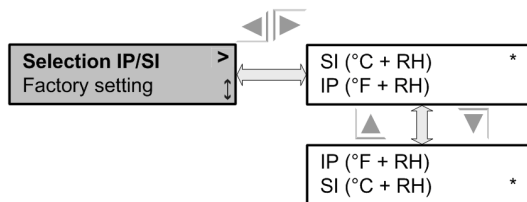

The selected unit of measurement is shown with a * .

5.11.8 Factory setting

The control can be reset to factory settings here.

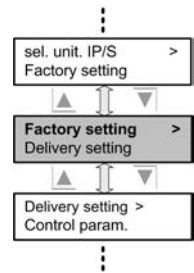

5.11.8.1 Control reset (factory setting)

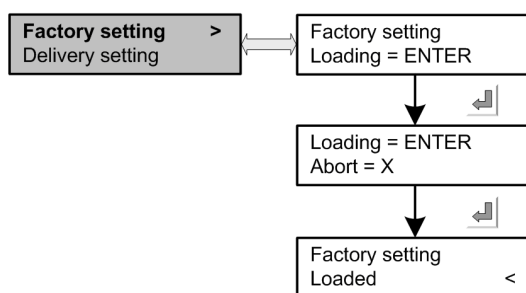

ADVICE

Any changes made locally will be deleted. Factory commissioning values will be retained. The control functions are reset to their default values.

See [Factory setting, Page 58](#)

5.11.9 Delivery condition

The control can be reset to delivery condition here.
Commissioning is then not necessary.

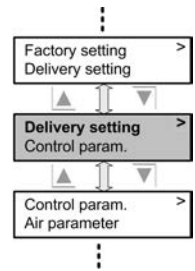

5.11.9.1 Control reset (delivery condition)

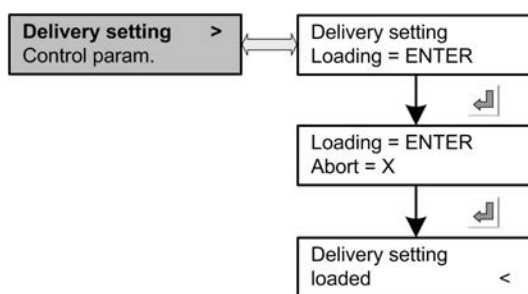

ADVICE

Any changes made locally and the commissioning values will be cleared. Once this function has been completed, a completely new factory commissioning must be carried out.

6 Faults and troubleshooting

6.1 General notes

Most faults that occur during commissioning are due to wiring faults or defective sensors. It is only in the rarest of cases that the Controller itself is defective. Check the following points before ordering a replacement:

Status info menu:

- Is a fault displayed in the info menu?
- If the message "Equipment failure" is displayed, there is a fault in the wetting controller.

Please check if there is voltage supply on the wetting controller.

- For other error messages, see Table [Error messages and warnings on the GMM display, Page 59](#)

TEST POINT 2:

Mains connection:

Sensor connection:

- Is the sensor connected correctly? Cf "Sensor connection" section
- Sensor OK? (Measure! Pressure: 4-20mA, Temp.: 4-20mA, default signal: 0-10V)
- Are the sensor cables laid in the immediate vicinity of the mains or motor cable? Consider increasing the distance!
- Are the sensor cables shielded? If not – swap for shielded cables!
- Is the shielding applied unidirectionally on the controller?

Fuses:

- Is the fuse on the controller supply OK?

7 Technical data

7.1 Dimensions and weight

Dimensions of GRCpad.1

You will find the casing dimensions below. All dimensions are given in millimetres.

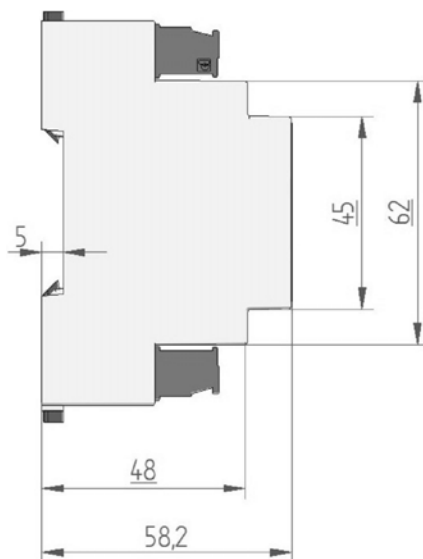
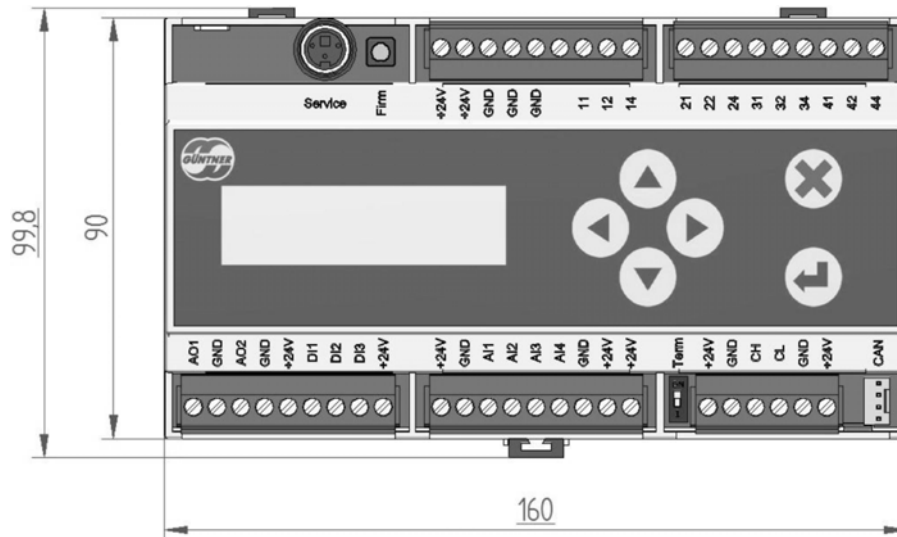

Dimensions of casing of GRCpad.1

Weight:
ca. 340g

8 Electrical properties of the components

Electrical properties of GRCpad.1				
	Min	Type	Max	Unit
Voltage supply	21	24	30	V
Current consumption		80	250 ¹	mA
Digital inputs				
High level	15	24	30	V
Low level	-3	0	5	V
Relay outputs				
Voltage DC		24	30	V
Voltage AC			250	V
Current resistive load 24V DC/250V AC			1	A
Current inductive load 24V DC/250V AC			1	A
Switch cycles, mechanical	1*10 ⁶			Hysteresis
Switch cycles, electrical	1*10 ⁵			Hysteresis
Voltage input				
Dielectric strength	-24		30	V
Measuring range	0		12	V
Resolution			10	bit
Fault			1	% ²
Input resistor:		230		kΩ
Current input				
Dielectric strength	-24		30	V
Measuring range	0		12	V
Resolution			10	bit
Fault			1	% ²
Input resistance (without protective circuit)		130		Ω

Table: Electrical properties of GRCpad.1

	Min	Type	Max	Unit
Voltage output				
Voltage range	0		10	V
Load voltage		>=100		kΩ
Resolution			10	bit
Fault			2.5	% ²
Short protection	Yes			
Potential separation	No			
Temperature input				
Dielectric strength	-24		30	V
Measuring range	-30		100	°C
Resolution			10	bit
Precision			3	% ²
CAN bus				
Dielectric strength	-24		24	V
Transmission rate		125		kbit/s
Galvanic separation	No			

Table: Electrical properties of GRCpad.1

1. The maximum current consumption includes supplying two attached pressure transponders and one attached temperature sensor.
2. Of the appropriate range

9 Factory setting

Wetting:	ON from rpm > OFF from rpm < ON from T >	60% 50% 22 °C
Draining:	Standstill time > External temp. <	24 h 6 °C
Efficiency mode:	Mode on/off Water costs Power costs	OFF 2.00 €/m ³ 0.22 €/kWh
Control parameters:	Kp factor Ti factor	0.4 45 s
Water parameters:	Base value Full load mode Increment Delay Max. Water supply factor Offset factor	50 l/h 100% 10% 3 min 1.3 1
Water fault:	Max. deviation Testing period	40% 5 min
Air fault:	Testing period	5 min.
Unit:		SI (°C + RH)

Table: Factory setting

10 Error messages and warnings on the GMM display

The table shows which signal relay (**PRIO 1** or **PRIO 2**) is tripped with which message on the display.

Messages/warnings on the display	PRIO 1	PRIO 2	Explanation
Start-up, please wait			The system was started
Start-up, please wait			Restart, internal software error
Temp. sensor / AI1 fault	x		Sensor not connected or defective, cable break
Wet. Sensor / AI2 fault		x	Sensor not connected or defective, cable break
U > 10V / AI4 fault		x	Voltage too high
Hydraulics NOK:		x	The valve is defective, the tubes are dirty or the water pressure is too low.
Air supply NOK		x	Differential pressure gauge has detected dirt.
Bus master OK			Registration at Bus master successful
Bus master NOK		x	Connection to BUS master lost.

Table: Error messages/warnings on the display

11 Troubleshooting tips

Error	Possible cause, suggested solution
Hydraulics NOT OK:	<ul style="list-style-type: none"> - Water supply turned off → Check - Not enough pressure to bring up necessary water volume (check water pressure in water system) - Control valve defective, blocked - Tubes dirty, furred up → Change
Air supply NOT OK:	Differential pressure switch tripped Clean→hydropads, heat exchanger
Sensor error:	Measure sensor (resistance measurement < 800Ω, or current < 2mA or >22mA)
Draining not possible:	Release valve defective or blocked → Check for mechanical defect caused by permanent magnet

Table: Error search - tips

12 Index

A	
Actual values.....	33
Air fault report.....	49
Airflow volume.....	46
Air parameters.....	46
Air speed.....	46
Alarm memory.....	39
Alarms.....	39
Analogue inputs.....	30
Analogue outputs.....	31
B	
Base value.....	46
Basic menu.....	32
C	
Collective fault.....	27
Commissioning.....	9
Commissioning menu.....	10
Configuration.....	25
Configuration table.....	25
Connections GRCpad.1.....	18
Construction of the GHM pad.....	12
Control inputs.....	28
Control parameters.....	45
Control reset (delivery condition).....	53
Control reset (factory setting).....	52
D	
Date.....	42
Date setting.....	42
Delay.....	47
Delivery condition.....	53
Differential pressure switch.....	29
Dimensions of GRCpad.1.....	55
Display.....	21
Draining.....	34, 37
Draining – external temperature.....	37
Draining Standstill time.....	37
Drive parameters.....	47
E	
EC/FU/leading edge.....	48
Edit mode.....	23
Efficiency mode ON/OFF.....	38
Efficiency mode – water costs.....	38, 38
Electrical properties of GRCpad.1.....	56
Electric power.....	48
Enable.....	28
Equipment failure.....	54
Error messages.....	59

Error search - tips.....	60
External air humidity.....	33
External enabling.....	36
External temperature.....	33, 37, 37
F	
Factory setting.....	52
Fan speed.....	33
Faults – General notes.....	54
Full load mode.....	47
Functional description of GRCpad.1.....	13
Fuses fault.....	54
G	
Geodata: height.....	38
GRCA.....	17
H	
H2O offset.....	47
Hardware and software versions.....	36
Humidity sensor connection.....	30
I	
Increment.....	47
Info menu.....	21
Installation / Operating conditions GRCpad.1.....	16
L	
Language.....	40
Language selection.....	40
M	
Manual mode.....	43
Manual mode ON/OFF.....	43
Matt ID.....	49
Max. flow.....	46
Max. H2O supply.....	47
O	
Operating menu.....	32
Operating mode.....	8, 35, 50
Operating mode setting.....	50
Operation.....	21, 22
Output (11/12/14).....	27
Output (21/22/24).....	27
Output (31/32/34).....	27
Output (41/42/44).....	27
P	
Parameters.....	37
password.....	44
Power costs.....	38
Proper intended use.....	5
S	
Safety instructions.....	5

Selection mode.....	24
Sensor connection fault.....	54
Service.....	44
Service menu.....	44
Service Number.....	7
SI/IP selection.....	51
Signalling outputs.....	27
Speed type.....	48
Standstill time.....	37
Status.....	35
System parameters.....	49
T	
Temperature sensor connection.....	30
Time.....	41
Time setting.....	41
V	
Valve control value.....	34
W	
Warnings.....	59
Water costs.....	38
Water fault report.....	49
Water flow.....	34
Water flow meter.....	29
Water meter.....	36
Water parameters.....	46
Water volume.....	34
Wetting – external temperature.....	35, 37
Wetting – frost protection.....	35
Wetting hours.....	36
Wetting OFF.....	35, 37
Wetting ON.....	35, 37

13 Picture index

Image 1:	Construction of the wetting controller GHM pad.....	12
Image 2:	Short description of the wetting controller GHM pad.....	13
Image 3:	Accumulated annual temperature.....	14
Image 4:	Controller GRCpad.1.....	17
Image 5:	Connection of external enable contact +24V – DI1.....	28
Image 6:	Differential pressure switch connection.....	29
Image 7:	Water flow meter connection.....	29
Image 8:	Temperature sensor + humidity sensor connection.....	30
Image 9:	Analogue outputs.....	31
Image 10:	Dimensions of casing of GRCpad.1.....	55

14 Table index

Table 1:	Configuration table GRCpad.1 input must be connected with checks.....	25
Table 2:	Configuration table GRCpad.1 None checks.....	25
Table 3:	Electrical properties of GRCpad.1.....	56
Table 4:	Factory setting.....	58
Table 5:	Error messages/warnings on the display.....	59
Table 6:	Error search - tips.....	60