

Operating instructions Wetting Controller GHM pad

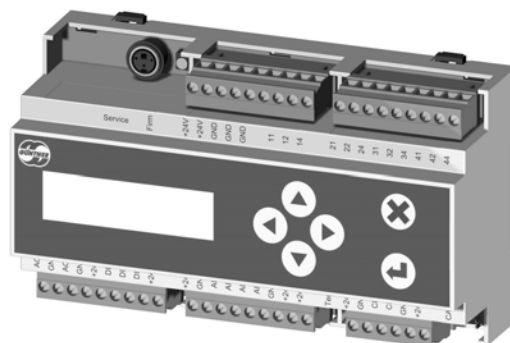

for the management and water volume control of condensers and dry coolers with HydroPads

www.guentner.de

Contents

1	General notes.....	5
1.1	Safety instructions.....	5
1.2	Use according to the intended purpose.....	5
1.3	Transport and storage, copyright notice.....	6
1.4	Warranty and liability.....	6
1.5	Manufacturer and delivery address	7
1.6	EMC-compliant installation.....	7
2	Operating mode.....	8
3	Commissioning GHM pad.....	9
3.1	The initial commissioning procedure.....	10
4	Construction of the GHM pad.....	12
4.1	Controller.....	13
4.1.1	Functional description.....	13
4.1.2	Installation / Operating conditions.....	16
4.1.3	Controller GRCpad.1.....	17
4.1.4	Connections.....	18
5	Display and operation.....	21
5.1	Info menu.....	21
5.2	Operation.....	23
5.3	Edit mode.....	24
5.4	Selection mode.....	25
5.5	Configuration.....	26
5.5.1	Configuration table.....	26
5.6	Floating signalling outputs.....	27
5.6.1	Digital output (11/12/14) (fault).....	27
5.6.2	Digital output (21/22/24) (warning).....	27
5.6.3	Digital output (31/32/34) (Wetting in operation).....	27
5.6.4	Digital output (41/42/44)(Draining valve).....	27
5.7	Control inputs.....	28
5.7.1	Digital input DI1.....	28
5.7.2	Digital input DI2.....	29
5.7.3	water quantity meter.....	30
5.8	Analogue inputs.....	31
5.8.1	Connecting a temperature sensor and humidity sensor to AI1/ AI2.....	31
5.8.2	Communication between speed controller and humidification con- trol.....	32
5.9	Analogue outputs.....	33

5.10	Operating menu.....	34
5.10.1	Actual values.....	35
5.10.1.1	Ambient temperature.....	35
5.10.1.2	External air humidity.....	35
5.10.1.3	Fan speed.....	35
5.10.1.4	Water volume.....	36
5.10.1.5	Valve control value.....	36
5.10.1.6	Draining.....	36
5.10.1.7	Water flow.....	36
5.10.2	Status.....	37
5.10.2.1	Wetting ON/OFF/Frost protection.....	37
5.10.2.2	External enabling.....	37
5.10.2.3	Hardware and software versions.....	38
5.10.2.4	Bus module.....	38
5.10.2.5	Operating mode.....	38
5.10.2.6	Relative operating hours.....	38
5.10.2.7	Absolute operating hours.....	38
5.10.2.8	Service call-out (in months).....	39
5.10.2.9	Service call-out (in hours).....	39
5.10.2.10	Water meter.....	39
5.10.2.11	Efficiency mode.....	39
5.10.2.12	Cleaning cycle.....	39
5.10.3	Parameters.....	40
5.10.3.1	Wetting.....	40
5.10.3.2	Draining.....	40
5.10.3.3	Efficiency mode.....	41
5.10.3.4	Geodetic height.....	41
5.10.4	Alarms.....	42
5.10.4.1	Alert memory.....	43
5.10.5	Language.....	44
5.10.5.1	Language selection.....	44
5.10.6	Time.....	45
5.10.6.1	Timesetting.....	45
5.10.7	Date.....	46
5.10.7.1	Set date.....	46
5.10.8	Manual mode.....	47
5.10.8.1	Manual mode settings.....	47
5.11	Service.....	48
5.11.1	Control parameters.....	49
5.11.1.1	Control parameter Kp, Ti.....	49
5.11.2	Air parameters.....	50
5.11.2.1	Airflow volume and air speed.....	50
5.11.3	Water parameters.....	50
5.11.3.1	Max. flow.....	50

5.11.3.2	Base value.....	50
5.11.3.3	Full load mode.....	51
5.11.3.3.1	Increment, delay, max. H2O supply.....	51
5.11.3.4	H2O offset.....	51
5.11.3.5	Cleaning cycle.....	52
5.11.4	Drive parameters.....	53
5.11.4.1	Type of speed control: EC/FU/leading edge.....	53
5.11.4.2	Electric power.....	53
5.11.5	System parameters.....	54
5.11.5.1	Fault report.....	54
5.11.5.2	Matt ID.....	54
5.11.6	External bus module.....	55
5.11.7	I/O configuration.....	56
5.11.8	SI/IP selection.....	57
5.11.8.1	SI/IP units system.....	57
5.11.9	Service interval.....	58
5.11.10	Factory setting.....	60
5.11.10.1	Control reset (factory setting).....	60
5.11.11	Delivery condition.....	61
5.11.11.1	Control reset (delivery condition).....	61
6	Faults and troubleshooting.....	62
6.1	General notes.....	62
7	Technical data.....	63
7.1	Dimensions of component -Dimensions / weight.....	63
8	Electrical properties of the component.....	64
9	Factory setting.....	66
10	Fault reports and warnings.....	67
11	Troubleshooting tips.....	68
12	Index.....	69
13	Picture index.....	73
14	Table index.....	74

1 General notes

1.1 Safety instructions

In order to prevent serious physical injuries or major material damage, work on/with the equipment may only be performed by authorised persons with the appropriate training and qualifications who are familiar with the set-up, installation, commissioning and operation of electronic controllers. These persons must read the operating instructions carefully before the installation and commissioning. In addition to the instructions and national accident prevention regulations, all recognised technical rules (safety and professional work under UVV, VBG, VDE, etc.) must be followed.

Repairs to the unit may only be made by the manufacturer or a repair centre authorised by the manufacturer.

UNAUTHORISED AND IMPROPER INTERVENTIONS WILL INVALIDATE THE WARRANTY!

The applicable national accident prevention regulations must be followed when working on control devices under voltage.

1.2 Use according to the intended purpose

The unit is intended only for the purposes agreed in the order confirmation. Any other application or use for any additional purpose, is not a proper intended use. The manufacturer accepts no liability for any injury or damage arising from unintended use. Use according to the intended purpose is also contingent on compliance with the installation, operating and maintenance procedures described in these instructions. The technical data and the details of the connection assignments can be found on the type plate and in the instructions, and must be complied with.

Electronic equipment is not fundamentally failsafe! The user must therefore ensure that his system reverts to a safe condition in the event of failure of the unit. The manufacturer accepts no responsibility for any damage to life and limb or to material goods and assets in the event of failure to comply with this provision and in the event of improper use.

The electrical installation must be performed in accordance with the relevant regulations (e.g. wire cross-sections, fuses, earth conductor connections, etc.). Additional information is included in the documentation. If the control device is used in a particular area of application, the required standards and regulations must be complied with.

1.3 Transport and storage, copyright notice

The control devices are packaged appropriately for transport and may only be transported in their original packaging. Avoid any impacts and collisions. Unless otherwise noted on the packaging, the maximum stacking height is 4 packs. When you receive the unit, check for any damage to the packaging or the control device.

Store the unit in its original packaging and protected from the weather, and avoid extremes of heat and cold.

Subject to technical changes in the interests of further development. Therefore no claims may be derived from information, images and drawings; errors excepted!

All rights, including rights created by patent grant or other registration, are reserved.

These operating instructions are the copyright of

GÜNTNER GmbH & CO. KG

Fürstenfeldbruck

1.4 Warranty and liability

The current General Terms and Conditions of Sales and Delivery of Güntner AG & Co. KG apply.

See the homepage at <http://www.guentner.com>

1.5 Manufacturer and delivery address

Should you have a problem with any of our units, or any questions, suggestions or special requests, simply contact

Güntner GmbH & Co. KG
Hans-Güntner-Strasse 2-6
D-82256 Fürstenfeldbruck, Germany

Service Telephone Germany:
0800 48368637
0800 GUENTNER

Service Telephone Worldwide:
+49 (0)8141 242-4815

Fax: +49 (0)8141 242-422
service@guentner.com
www.guentner.com

Copyright © 2018 Güntner GmbH & Co. KG

All rights, including rights of photomechanical reproduction and storage in electronic form, are reserved.

1.6 EMC-compliant installation

Controllers in the GHM pad series fulfil the requirements of EN 61000-6-2 as regards resistance to EMC interference and those of EN 61000-6-3 as regards emissions.

They also comply with standards IEC 61000-4-4/-5/-6/-11 for grid-bound interference.

In order to guarantee EM compatibility, the following points must be noted:

- All measurement and signal lines must be connected via shielded cables.
- The shielding of measuring, signal and bus lines must be earthed *at one end* only.
- Suitable shielding and routing measures must be taken to ensure that mains cables and motor cables do not cause any interference in signal and control lines.

The GRCA controller module and any expansion modules are mounted on a top-hat rail and are attached to an earthed mounting panel in the switch cabinet. The electrical supply is connected with cable connectors.

NOTICE

If the equipment is installed in a switch cabinet, **proper attention must be given to the** temperature inside the cabinet. Güntner switch cabinets are provided with sufficient ventilation.

2 Operating mode

The controller calculates the amount of water on the basis of the ambient conditions and the speed of the fans. If the external temperature and the fan speed are higher than the specified start value for humidification (Parameters menu→ Humidification→ External temperature/Humidification ON), then humidification is activated. If the speed or external temperature fall below the specified values, then humidification is deactivated (Parameters menu→ Humidification→ Humidification OFF, external temperature).

Partial load operation/Efficiency mode

If the speed is above the set value to start the wetting (Parameters menu→ Wetting→ Wetting ON) and below the threshold for full load mode, the controller works in partial load operation. In partial load operation only as much water as the HydroPads can evaporate is given off. If efficiency mode is activated (Parameters menu→ Efficiency mode), wetting controller looks for the most cost-effective operating point between speed (power costs) and water volume (water costs). The costs can be set in the→ Efficiency mode→ Water costs, Power costs parameters menu. The wetting controller always searches here after a delay for the new most cost-effective operating point.

Full load operation

If the speed reaches the threshold value for full load mode (Service menu → Water parameters → Full load mode), then the unit increases the amount of water sprayed. If, after the specified delay (Service menu → Water parameters → Delay), the speed is still above the specified value for full load mode, the water volume is increased incrementally. This continues until the specified maximum quantity of H₂O is introduced (Service menu → Water parameters → Max. H₂O supply), provided the speed remains higher than the figure for full load mode.

If you selected full load mode when configuring the digital inputs (Service menu → I/O configuration → Digital inputs → DIx), then full load operation begins only when the DIx input is switched and the speed has reached the threshold value for full load mode.

If the speed drops below the threshold value the controller will switch back to partial load operation and the quantity of water will be gradually reduced.

Partial load operation without wetting

If the speed or the external temperature are below the set start value for the wetting, it remains inactive.

3 Commissioning GHM pad

The humidification controller communicates with the fans' speed controller via a 0-10V signal. If the speed controller is a GMM EC, communication may be either via the 0-10V signal or the CAN bus.

The wetting controller must be set up in accordance with the configuration of the heat exchanger and the fans.

When switched on the wetting controller automatically recognizes whether commissioning has already been carried out and, if it has, continues with normal operation.

If the GHM pad detects that it has not yet been commissioned, it initiates the commissioning procedure. When this procedure has been completed, all the specified parameters are saved. Apart from those pertaining to CAN bus communication, all the values set up during the commissioning process can subsequently be viewed and changed individually via the menus.

3.1 The initial commissioning procedure

If it is recognized that commissioning has not yet taken place, the following values are interrogated and set up in accordance with the following flow chart.

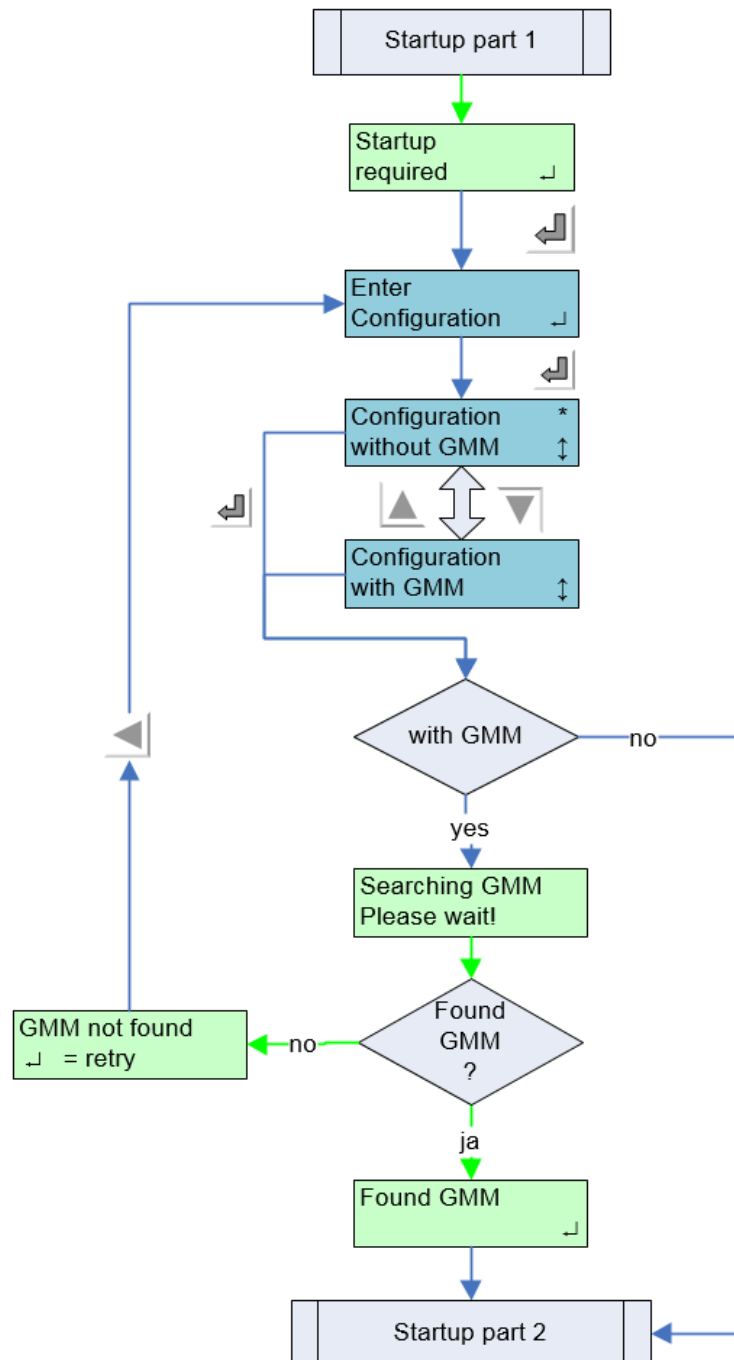

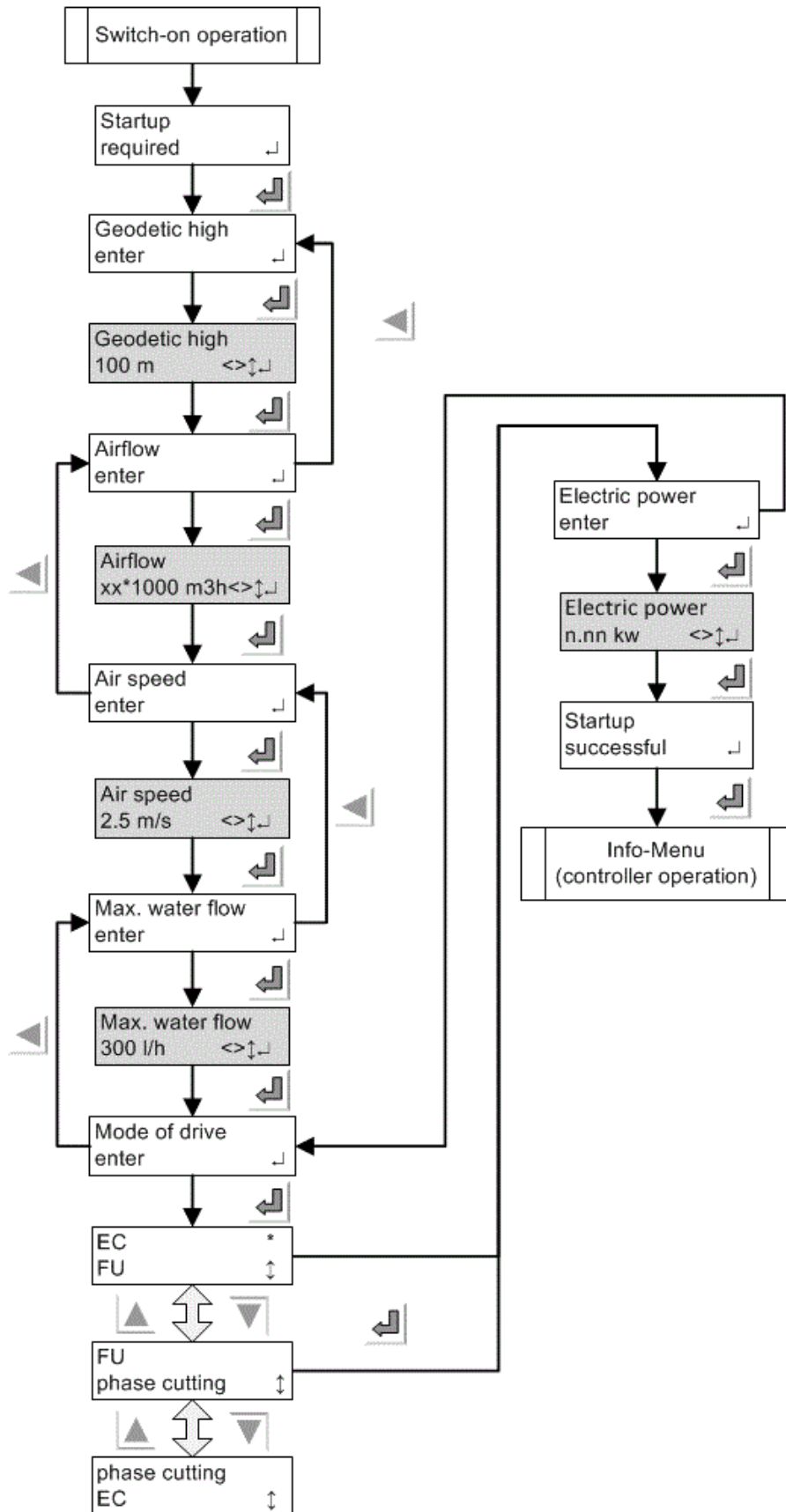

4 Construction of the GHM pad

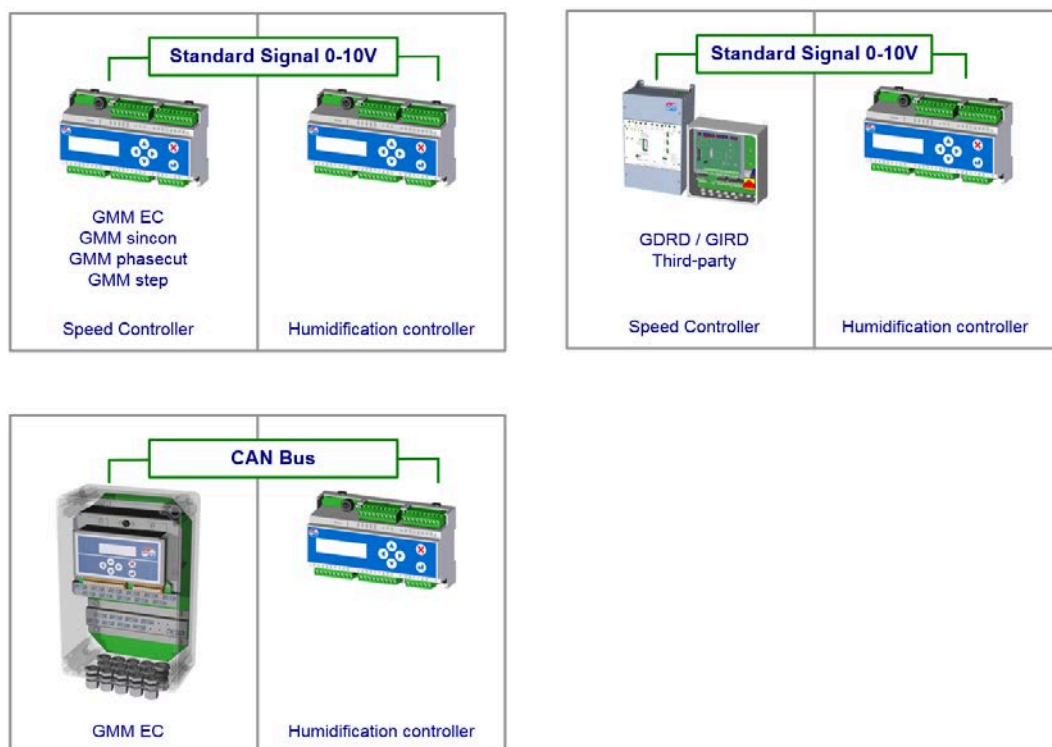

Construction of the humidification controller GHM pad

The wetting controller consists of the following components:

1. Wetting controller (right)
2. Fan speed controller (left)

The humidification controller GHM pad can be combined with all the continuous Guntner speed controllers (GMM EC, GMM sincon®, GMM phasecut, GMM step, GDRD, GIRD).

The GHM pad can also be operated with other speed controllers, provided a 0-10V signal (fan control value) is available.

The control signal must be connected to the AI4 terminal of the humidification controller.

If you combine a GHM pad with a GMM EC controller, the fans' control value can also be communicated via the CAN bus. For CAN bus communication to be a possibility, both the humidification controller and the GMM EC controller must be brought up to a software version that supports this.

4.1 Controller

4.1.1 Functional description

Functional description of GRCpad.1

The wetting system is used for increasing the capacity of heat exchangers at peak load times with high ambient temperatures and for more efficient heat dissipation with moderate ambient temperatures. The adiabatic evaporation of the water on the hydropads cools the air sucked in by the heat exchanger, which increases the heat exchanger's capacity.

The wetting controller GHM pad governs the regulation of the wetting process. The required water volume is calculated on the basis of the load state, the ambient temperature and the humidity. The GHM pad sets the appropriate water volume using the control valve. The system's frost protection is secured with automatic draining. The water supply to the unit must be protected separately against frost.

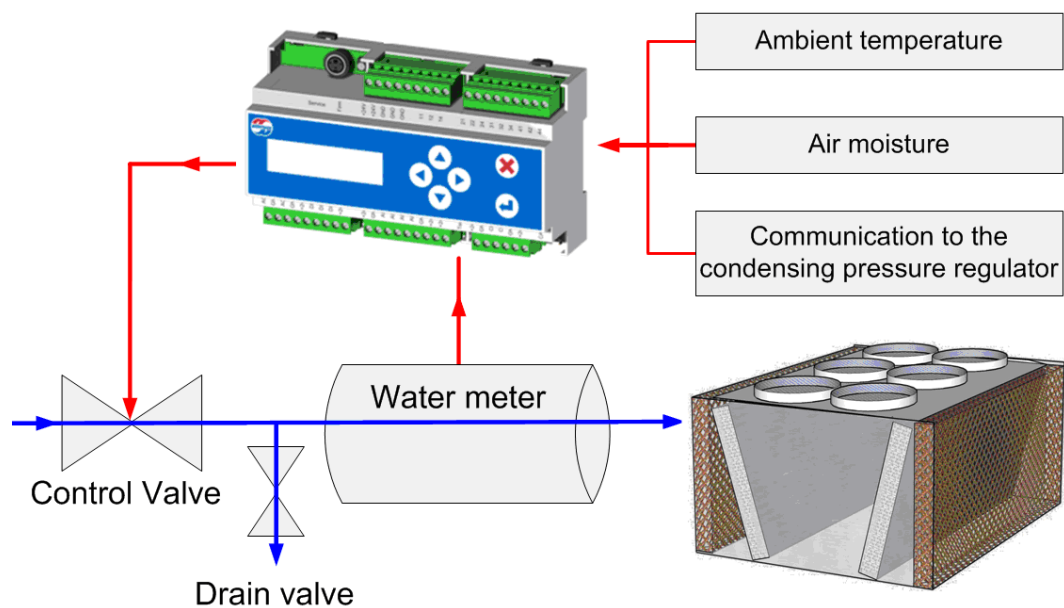

Short description of the wetting controller GHM pad

In order to ensure controlled operation, the controller must have a power supply and must be enabled via digital input DI1. If it is not enabled the process will not be regulated.

The digital inputs are designed as potential-free contacts that must be connected to +24V.

NOTICE

Please note that connecting the wrong voltage (e.g. 230V) may seriously damage the controller.

An analogue output is used to control a steady regulating valve that governs the amount of water on the wetting mats.

Relay outputs are used to control solenoid valves and activate system messages and alarms. The CAN interface of GRCpad.1 is an internal interface for communicating with other Guntner units.

The following communications modules are available for external bus connections: for Modbus (GCM MOD GHMpad Rail.1, ERP No.: 5206139).

An accumulated annual temperature profile is shown below. As you see, the outlet temperature with dry coolers and the condensing temperature with condensers both depend on the ambient temperature.

The following explanations use only the term "condensing temperature". Note that the same information applies to the "outlet temperature" of a dry cooler.

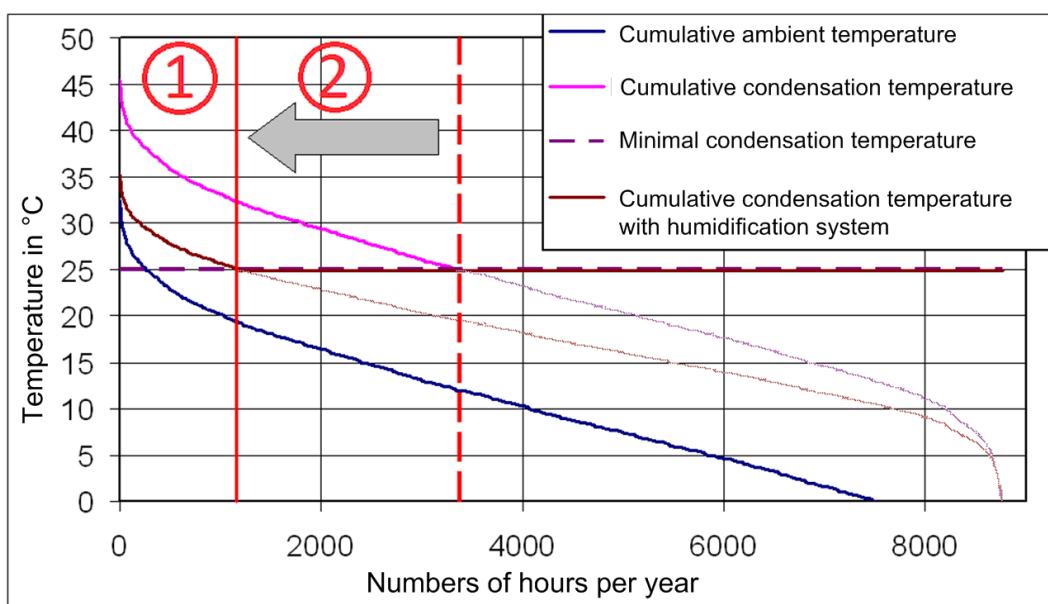

Accumulated annual temperature

A setpoint is set on the fans' speed controller for the minimum condensing temperature. If this setpoint is not reached because of high ambient temperatures, the fans run at full speed and the heat exchanger is in full load operation. The condensing temperature follows the ambient temperature in this operating state.

If the set minimum condensing temperature is reached, the fan speed is reduced to prevent any further reduction of the condensing temperature. The cooling of the air at the HydroPads increases the capacity of the heat exchanger. The additional wetting reduces the condensing temperature, which displaces the demarcation between full load operation (indicated by 1 in the diagram) and partial load operation (2). The dotted red line is the demarcation between full load operation and partial load operation in dry operating mode. The continuous line separates full load operation from partial load operation when wetting is also active. The controller distinguishes between three operating modes.

1) Full load operation:

- The fans run at full speed.
- The minimum condensing temperature is not reached.

The water volume can be increased in full load operation to achieve higher air cooling.

2) Partial load operation without efficiency mode:

- The fans are in controlled operation.
- The minimum condensing temperature is reached.

The wetting controller calculates the required water volume according to the ambient conditions so that, as far as possible, 100% of the supplied water will evaporate.

3) Partial load operation with efficiency mode:

- The fans are in controlled operation.
- The minimum condensing temperature is reached.

The wetting controller measures the water volume so as to minimise the total cost for fan drive and water. The controller calculates the most cost-effective operation on the basis of the entered water and power costs. The GHM pad calculates whether it is more cost-effective to dissipate the heat by evaporation cooling or by convection.

The controller is in full load mode or partial load mode, depending on whether the evaporation set-point was reached or not. Efficiency mode for partial load operation can be activated in the parameters of the controller.

4.1.2 Installation / Operating conditions

Installation / Operating conditions GRCpad.1

- The module is designed for mounting on a top-hat rail.
- All measurement and signalling lines must be connected via shielded cables.
- The shielding of measuring, signal and bus lines must be earthed at one end only.
- Suitable shielding and routing measures must be taken to ensure that mains cables and motor cables do not give rise to any interference in signal and control lines.
- Temperature:
Storage, Transport: -20°C ... +70°C
Operation: -20°C ... +65°C
- Protection rating: IP 20
- Recommended cables: Belden 9841, Lapp 2170203, Lapp 2170803, Helukabel 81910

4.1.3 Controller GRCpad.1

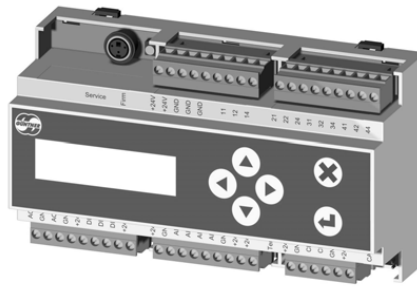

Controller GRCpad.1

The water volume is regulated by the controller in accordance with the ambient conditions and the speed of the fans.

The equipment is controlled by means of menus using a 2-line display and an input keyboard.

4.1.4 Connections

Connections GRCpad.1

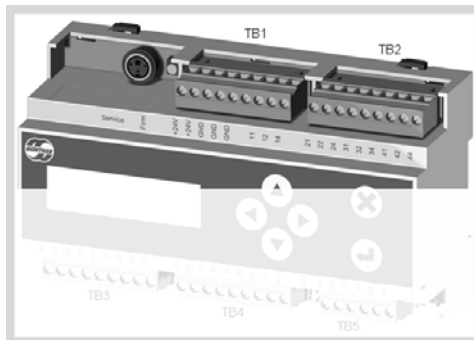

Upper row of connections				
	Name	Description		
	Service	Service plug only for use by service personnel		
	Firm	Pushbutton only for use by service personnel		
TB1	+24V	External feed for power supply		
	+24V			
	GND	Contact ground for external power feed		
	GND			
	GND			
		Terminal not connected		
TB2	11		Relay DO1	
	12			
	14			
	21		Relay DO2	
				22
				24
	31		Relay DO3	
				32
				34
	41		Relay DO4	
				42
				44

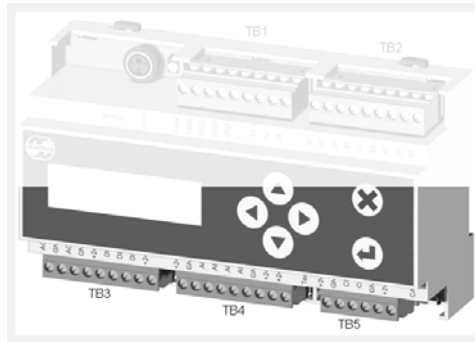

Lower row of connections		
	Name	Description
TB3	AO1	Analogue output 1, 0#10V
	GND	Ground
	AO2	Analogue output 2, 0#10V
	GND	Ground
	+24V	Voltage +24V
	DI1	Digital input +24V
	DI2	Digital input +24V
	DI3	Digital input +24V
	+24V	Voltage +24V
TB4	+24V	Voltage +24V
	GND	Ground
	AI1	Analogue output 4#20mA
	AI2	Analogue input 4-20mA or for temperature sensor GTF must be configured in the software
	AI3	Analogue input for temperature sensor GTF
	AI4	Analogue input 0#10V
	GND	Ground
	+24V	Voltage +24V
	+24V	Voltage +24V
	Term	DIP switch for CAN bus termination (120Ω) / ON = termination activated
TB5	+24V	Voltage +24V
	GND	Ground
	CH	CAN high signal
	CL	CAN low signal

Lower row of connections		
	GND	Ground
	+24V	Voltage +24V
	CAN	CAN bus plug including power supply

*TB: Terminal block

5 Display and operation

Information are shown on a 2-line display. The control device is operated via a membrane keyboard.

5.1 Info menu

The current operating status of the controller is displayed in the Info menu. This shows both whether or not the system is currently being humidified and the reason for this status.

There are a number of “flashing” messages that are displayed as and when required and change every five seconds.

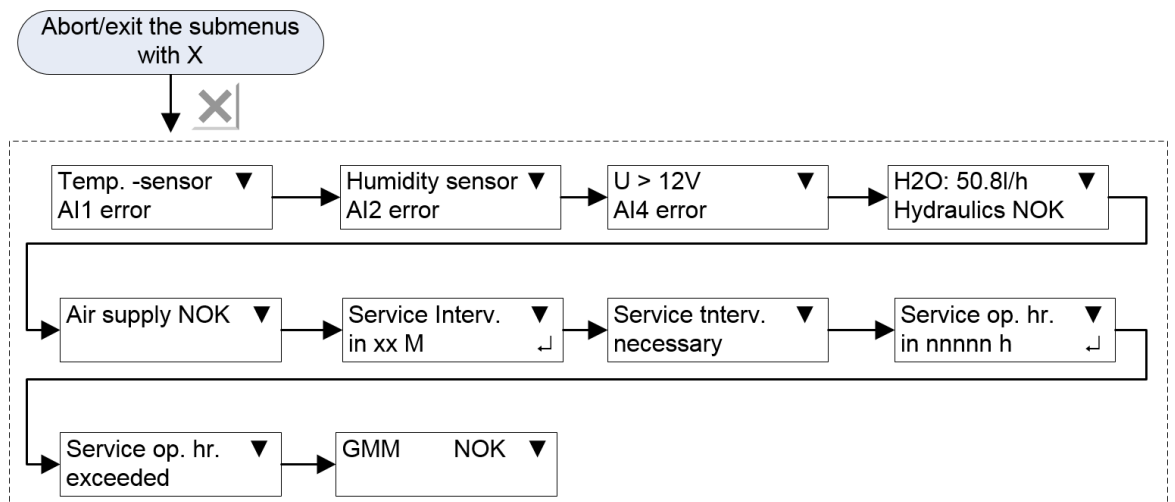

Info menu
Manual mode ▼ active
Draining ext. ▼ active
Contact DI1 ▼ error
Outside: -10.5°C ▼ Frost protect.
Outside: 21.2 °C ▼ Humidif. off
Fan speed: 50% ▼ Humidif. off
Water threshold ▼ not reached
H2O: 50.8 l/h ▼ Humidif. on
Reinigungslauf ▼ Humidif. on

The standard message has a hierarchical structure and usually indicates either that the system is humidifying or why it is not. This exact message is also displayed as the first entry in the Status menu.

5.2 Operation



Cancel and return to INFO menu



Enter key for function selection; change to EDIT mode and value acceptance



Right arrow for moving to the next menu level



Left arrow for moving to the previous menu level





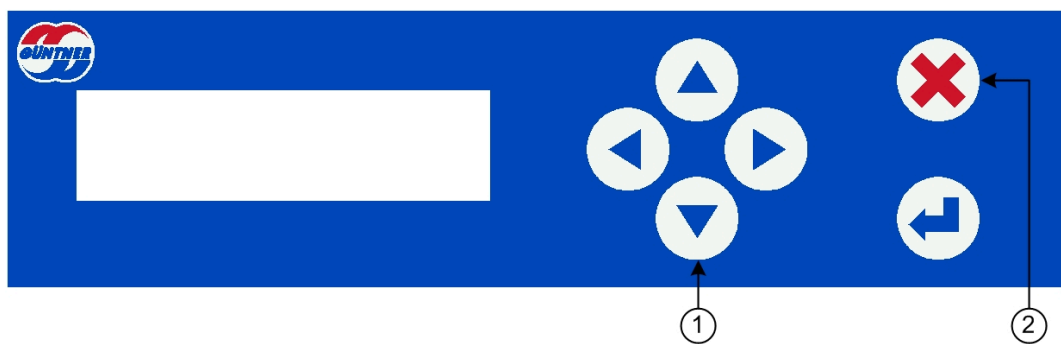







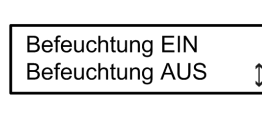

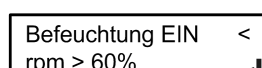

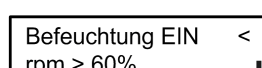
Up/down arrow for scrolling through the menu level

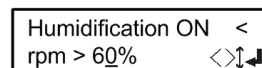

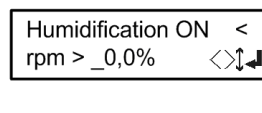
1. Use this key to move from the **"INFO"** menu to the **Operating menu**
2. Use this key to return to the **"INFO"** menu at any time

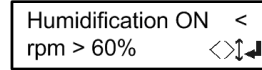
5.3 Edit mode

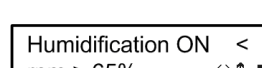
This mode is required to change values (for example control values).

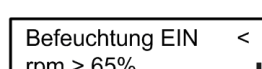
	Select the required menu option (top line)	
	Switch to menu option	
	Switch to write mode (cursor flashes)	
	Decimal point selection (cursor flashes)	
	Change value	
	Change value	
	New value acceptance	
	New value acceptance	

5.4 Selection mode

This mode is required to select functions (for example language).



Select the required menu option
(e.g. "Language", top line)

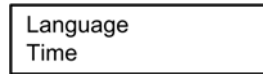

Change to menu option
→ The function/language currently set is marked with an *asterisk*.

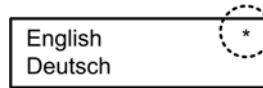

Set target language by scrolling to the top line
→ selected function/language in top line

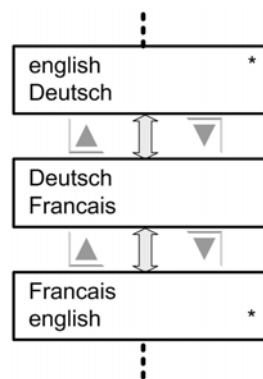

Accept function/language.
→ selected language is marked with an *asterisk*.

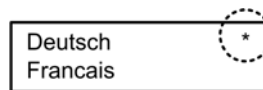

5.5 Configuration

The GHM pad is configured with an appropriate number of potential-free contacts. Their assignments will differ depending on the configuration.

5.5.1 Configuration table

GRCpad.1

	I/O	Signal	Function
GRCpad.1	DI1	24V	Enabling / full load mode / no function
	DI2	24V	Differential pressure switch / external drain signal / full load mode / no function
	DI3	24V	Pulse input from water flow meter
	AI1	4..20mA	Temperature sensor 4..20 mA (#35...+75°C) **
	AI2	4..20mA/KTY	Humidity sensor 4..20 mA (0...100% rel.hum.)
	AI3	KTY	No function
	AI4	0..10V	Fan setting 0..100%
	AO1	0..10V	Control valve
	AO2	0..10V	No function
	DO1	Relay	Fault
	DO2	Relay	Warning
	DO3	Relay	System message Wetting is active
	DO4	Relay	Draining valve
CAN BUS			Data from GMM EC: Unit system / fan control value

[Configuration table GRCpad.1](#)

** The measuring range of the temperature sensor must be set up accordingly. You will find the necessary information in the corresponding data sheet.

If you use the combined temperature and humidity sensor AFTF#1 (BAAN 5204798) you will need to set DIP switches DIP 1 and DIP 2 to ON.

5.6 Floating signalling outputs

For safety reasons, the floating fault indication outputs (changeover contacts) are designed in such a way that the corresponding signal relay is deactivated when the event is triggered, i.e. the opener of the corresponding changeover contact closes.

This has the effect that a malfunction is also signalled if the controller loses power due to a fault.

All signalling outputs must not exceed 250 V / 1 A.

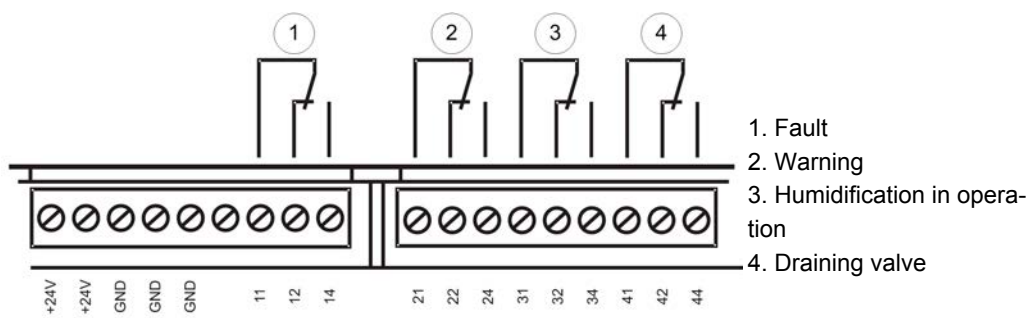

Floating signalling outputs

5.6.1 Digital output (11/12/14) (fault)

The message on the contact 11/12/14 is a fault that endangers the humidification system,.

A defective temperature sensor could not start the frost drain, which would result in the water system freezing.

Contact 11/12 is closed in alarm status.

Alarms, see [Fault reports and warnings, page 67](#)

5.6.2 Digital output (21/22/24) (warning)

Signals on contact 21/22/24 are warnings that do not result in the complete failure of the humidification system. These are warnings that the operation of the humidification system is impaired.

Contact 21/22 is closed when a warning is issued.

5.6.3 Digital output (31/32/34) (Wetting in operation)

The two-way contact (31/34) is closed as soon as a water flow exists.

5.6.4 Digital output (41/42/44) (Draining valve)

The two-way contact (41/44) is closed when draining is inactive.
The draining valve is opened without power.

5.7 Control inputs

The control inputs are designed as a **low-voltage connection** and are connected via a floating contact (relay, contactor contact, switch etc.).

The floating contact must be switched between the terminals **+24V** and the control input **DI1** or **DI2** or **DI3**. The function is activated when the contact is closed.

5.7.1 Digital input DI1

Controller enable or full load mode

The digital input **DI1** can be configured either for the function “full load mode” (see [Full load mode, page 51](#)) or for “external enable”.

If, in the I/O configuration menu, you assign input **DI1** to any function other than “external enable”, then the controller will be permanently enabled.

In the factory settings this input is assigned to “external enable” and is always bridged.

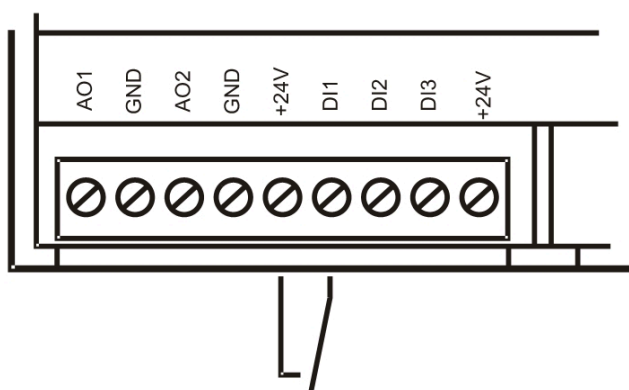

Connection of external enable contact +24V – DI1

NOTICE

Under no circumstances may the controller be disabled by interrupting the power supply! Continuously switching the supply voltage can damage the control device, and such damage is not covered by the warranty!

Enable is not required in “Manual mode”.

See [Manual mode, page 47](#)

5.7.2 Digital input DI2

(Differential pressure switch, ext. drain or full load mode)

A differential pressure switch can be connected to the “DI2” terminal of the humidification controller. If the HydroPads and the heat exchanger are dirty, the downstream pressure loss increases and the system goes to alert, provided the pressure does not fall below the value set on the differential pressure switch during the configured testing period (Service menu → System parameters → Fault report → Air → Testing period). The configured testing period prevents faults being caused by brief air turbulences. The differential pressure switch is set in the factory when the unit is commissioned. If the input for the pressure switch is activated, then the “Air supply NOK” alarm is issued. If the input is not switched again, the alarm continues to be displayed and is listed in the alarm history.

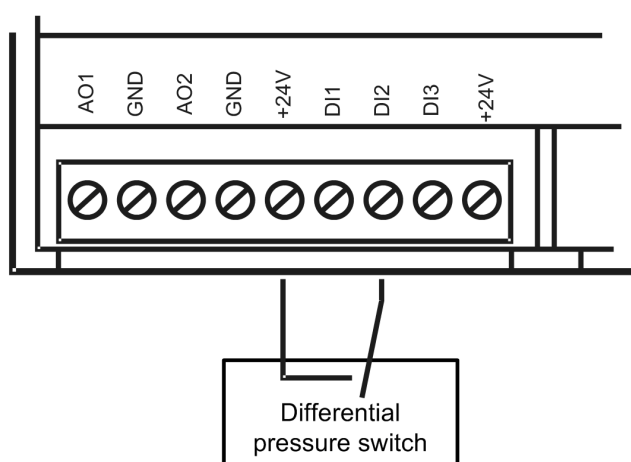

Differential pressure switch connection

Alternatively, input DI2 can also be used for receiving an external drain signal (see [I/O configuration, page 56](#)). By switching the input to a high level in this case, the controller can be induced to open both the solenoid valve for draining as well as the control valve fully. This function is useful for example if the supply is to be drained from outside.

The DI2 input can also be assigned to the function “full load mode” (see [Full load mode, page 51](#)). Full load mode will be active if the DI2 input is switched and the speed has reached the threshold value for full load mode.

5.7.3 water quantity meter

A pulse is sent from the water flow meter via the "DI3" terminal to the controller.

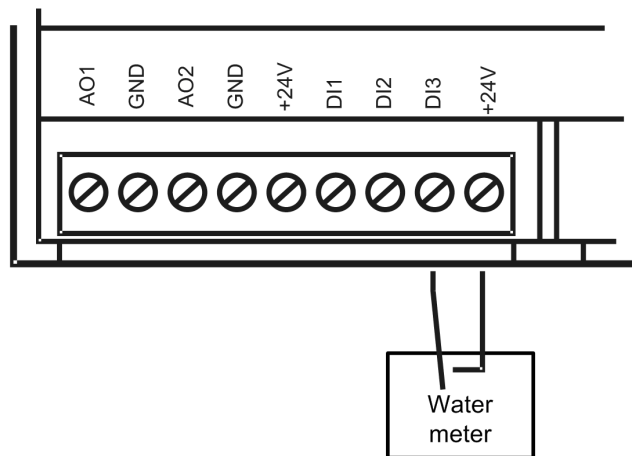

Water quantity meter connection

5.8 Analogue inputs

The humidification control has four sensor inputs:

Input AI1	Current input	4-20mA
Input AI2		4-20mA
Input AI3	empty	
Input AI4	Voltage source	0-10V DC

5.8.1 Connecting a temperature sensor and humidity sensor to AI1/AI2

Two sensors are connected.

+24 V = Common supply voltage

AI1 = 4-20 mA signal from temperature sensor

AI2 = 4-20 mA signal from humidity sensor

GND = Earth (negative)

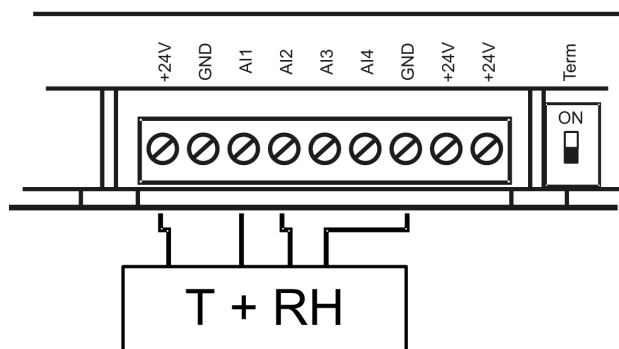

Temperature sensor + humidity sensor connection

5.8.2 Communication between speed controller and humidification control

A standard signal (0-10V) is connected on the following terminals

GND = Earth (negative)

AI4 = Control signal 0-10V DC (**max. 12V DC**)

Make sure the polarity is correct (earth to **GND**, signal to **AI4**).

The speed controller sends the fans' control value to the humidification control .

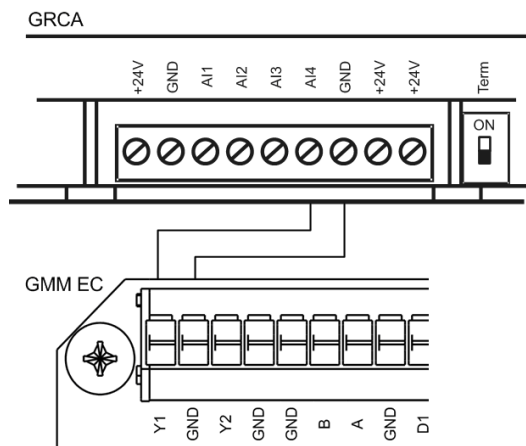

Communication between speed controller and wetting controller

5.9 Analogue outputs

The control unit has 2 analogue outputs with 0..10V output voltage.

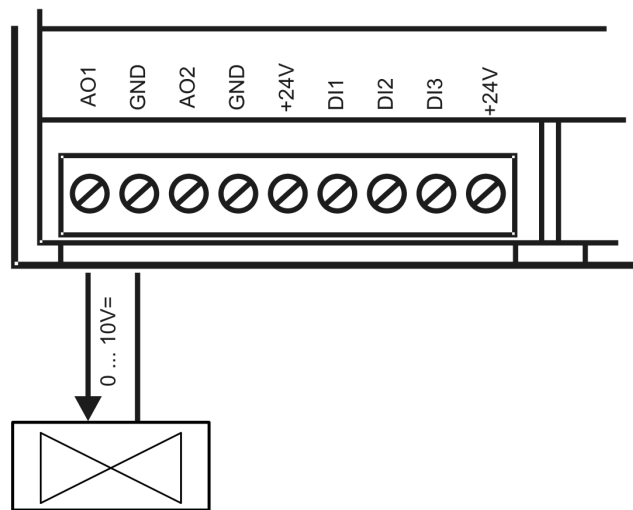

Analogue outputs

The **AO1** output issues the control signal (0..100%) scaled on 0..10V (for the control valve) .
Output **AO2** is not seized.

5.10 Operating menu

Structure of basic menu

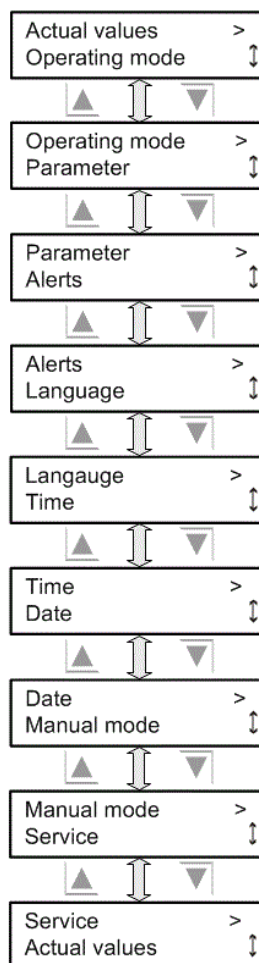

NOTICE

When the humidification controller communicates with the GMM EC via the CAN bus, all the values are displayed in the unit system that is currently set up in GMM. The unit system is defined on a one-time basis when the controller is started. This means that the controller then has to be restarted if the unit system is changed by GMM.

5.10.1 Actual values

The current input signals and control values are shown here.

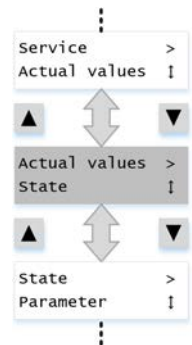

5.10.1.1 Ambient temperature

The current ambient temperature is shown.



5.10.1.2 External air humidity

The actual external air humidity is shown.

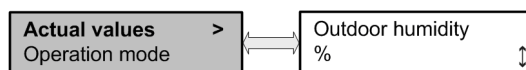

5.10.1.3 Fan speed

The current fan speed is shown. This is shown as a percentage of the maximum speed.

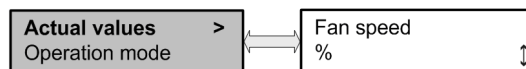

5.10.1.4 Water volume

The currently calculated water volume is shown in l/h.

The water volume is calculated from the ambient conditions.

Full load mode: The calculated water volume is multiplied with a factor resulting from the increment, delay and max. H2O supply. If the threshold value is reached, the water volume is increased incrementally with the set delay, up to the maximum value set in the Service menu.

Partial load operation with efficiency mode: The water volume is calculated to determine costs. The most cost-effective operating point between speed (power costs) and water volume (water costs) is determined here.

Partial load operation without efficiency mode: Only as much water as the HydroPads can evaporate is applied.

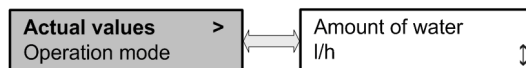

5.10.1.5 Valve control value

The water valve control value (0-10V) is displayed.

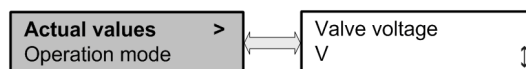

5.10.1.6 Draining

Whether draining is active or inactive is displayed.

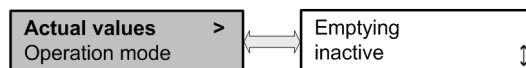

5.10.1.7 Water flow

The water meter shows the recorded water flow.

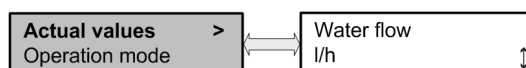

5.10.2 Status

The operating status values, efficiency mode settings, operating hours, water quantity and software/hardware versions are displayed here.

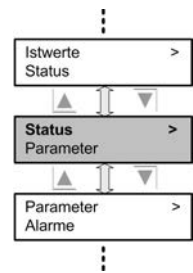

5.10.2.1 Wetting ON/OFF/Frost protection

The operating status that the system is in is displayed here. The corresponding actual value is also shown.

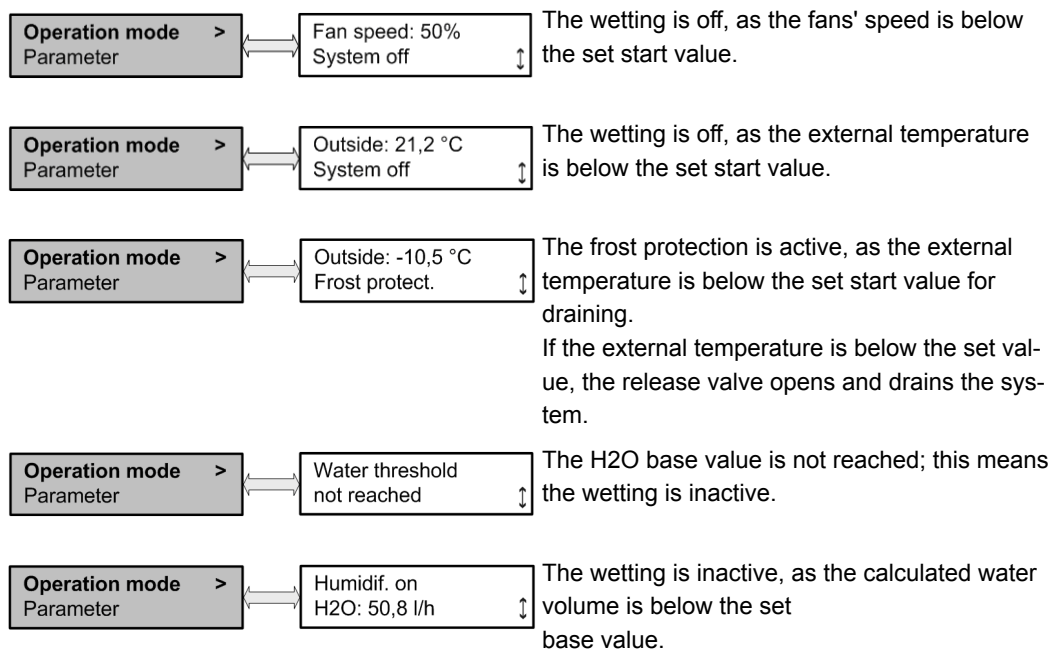

5.10.2.2 External enabling

Controller at connection **DI1** enabled **OK** or not **None**

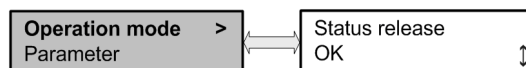

5.10.2.3 Hardware and software versions

The current hardware and software version is displayed here.

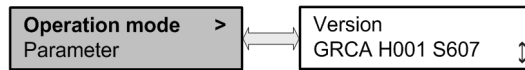

5.10.2.4 Bus module

This display provides information on the module type, firmware version and the address of the GCM bus module, when it is connected.

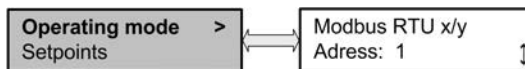

5.10.2.5 Operating mode

This shows the current operating mode in which the GMM and the wetting controller are communicating.

Communication via a 0..10V signal is supported exclusively at present. The GMM EC controller can also communicate with the humidification controller via the CAN bus.

If manual mode is active, its operating status is displayed.



5.10.2.6 Relative operating hours

The relative operating hours of the humidification function are shown here.



5.10.2.7 Absolute operating hours

The absolute operating hours of the humidification function are shown here. The absolute operating hours are reckoned from the initial start-up and cannot be reset.



5.10.2.8 Service call-out (in months)

This shows the remaining operating time in months before a service call-out is due.

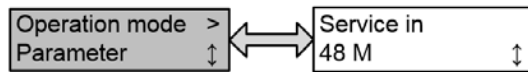

5.10.2.9 Service call-out (in hours)

This shows the remaining operating time in hours before a service call-out is due.

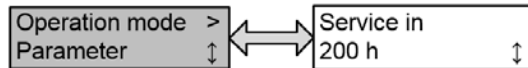

5.10.2.10 Water meter

The current volume of water used is displayed here.

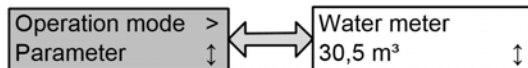

5.10.2.11 Efficiency mode

If efficiency mode is active it is displayed here, as are the power and water costs that were set in the Parameters menu (see [Parameters, page 40](#)).

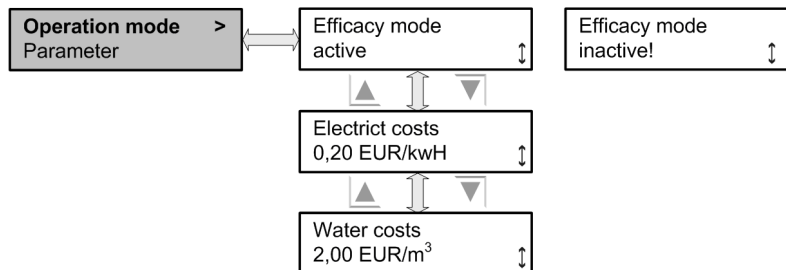

5.10.2.12 Cleaning cycle

The current operating status of the cleaning cycle is displayed here.

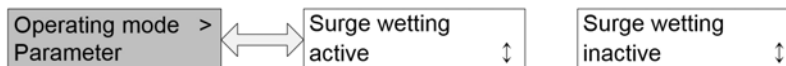

5.10.3 Parameters

The parameters are configured in this menu.

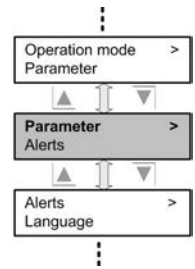

5.10.3.1 Wetting

Wetting ON/external temperature

The wetting starts if the speed and temperature are exceeded.

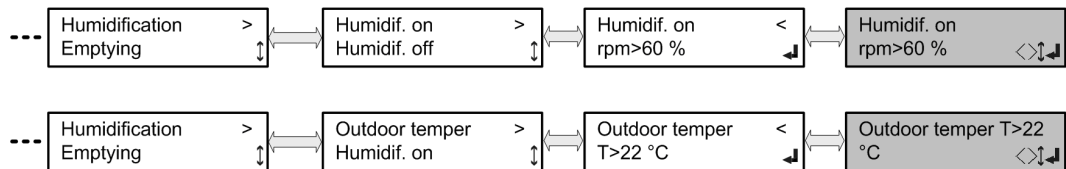

Wetting OFF

The wetting switches off when the speed falls below the set speed.

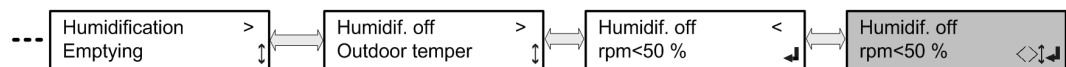

5.10.3.2 Draining

Standstill time

The draining valve is automatically opened and the system drained after the set standstill time.

Note: Legionella bacteria can form after lengthier periods of water standing still in the system.

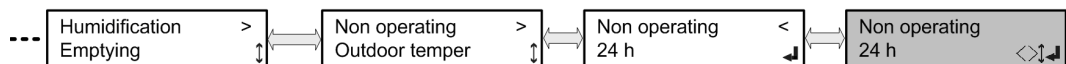

External temperature

If the temperature falls below the set temperature the system is drained to prevent freezing.

Note: The water supply to the system must be protected separately against frost.

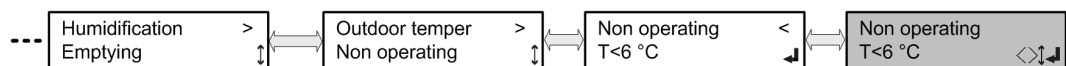

5.10.3.3 Efficiency mode

ON/OFF

If the efficiency mode is activated, the calculates the most cost-effective combination of water volume and fan speed in every operating situation, so that the average setpoint set in the speed controller is reached.

Note: The power and water costs must be entered in the Costs menu for the calculation.

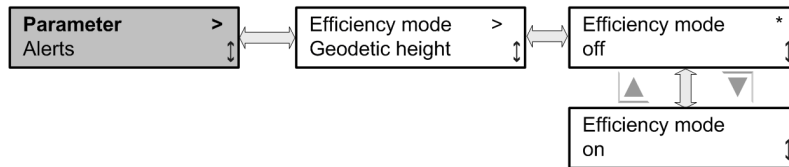

Water costs

If the efficiency mode is activated, the water costs are required for the cost efficiency calculation.

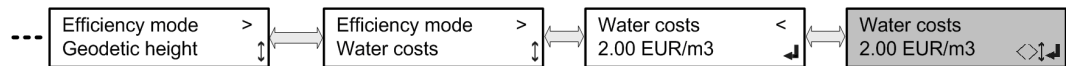

Power costs

If the efficiency mode is activated, the costs incurred per kilowatt hour consumed are required for the cost efficiency calculation.

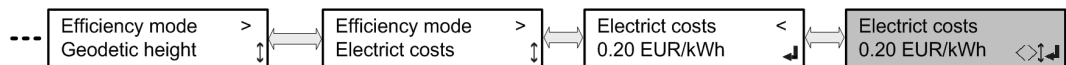

5.10.3.4 Geodetic height

The set-up height geodata must be entered for the water volume calculation, as the air density falls as height increases.

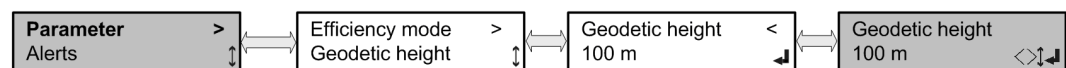

5.10.4 Alarms

The most recent 85 alarms can be called up here.

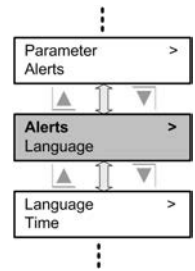

5.10.4.1 Alert memory

The humidification controller has an alarm memory that can accommodate up to 85 fault reports, activation and reset times stored consecutively (cyclically). These reports consist of the fault and the time stamp, comprising the date and time at which the fault occurred. For a list of fault reports and warnings see [Fault reports and warnings, page 67](#).

When the alert memory is selected, the display shows the last fault that occurred.

Use the “down” arrow key to display older faults.

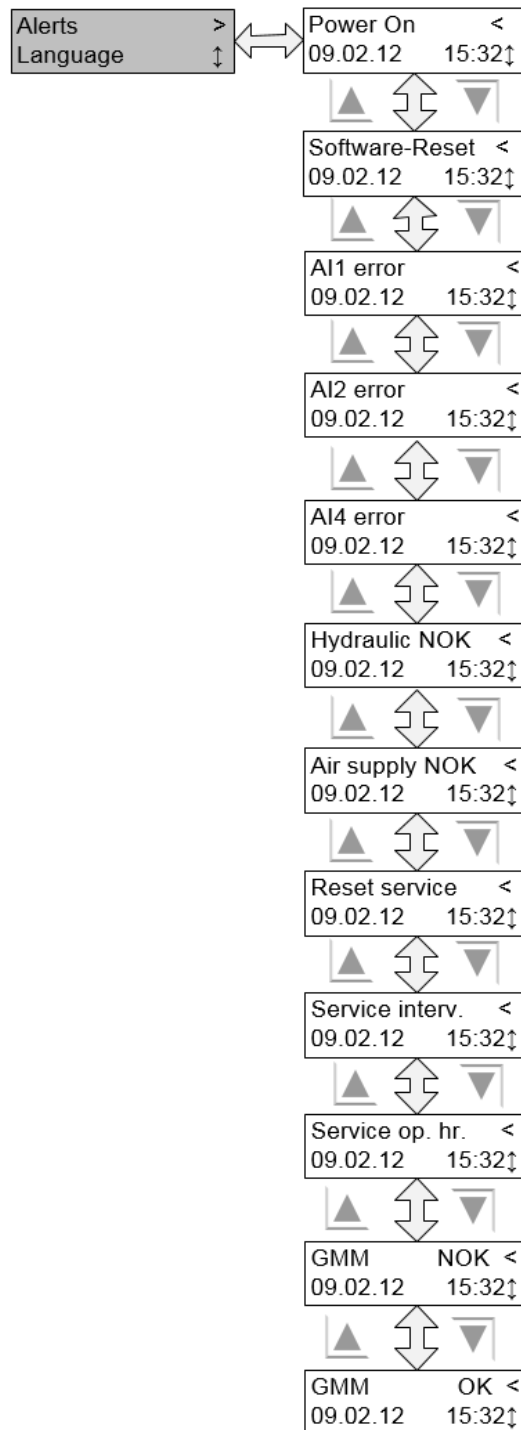

5.10.5 Language

The menu language can be selected here.

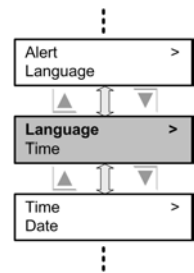

5.10.5.1 Language selection

In the language selection menu 3 languages can be selected. The currently selected language is marked with an *asterisk*.

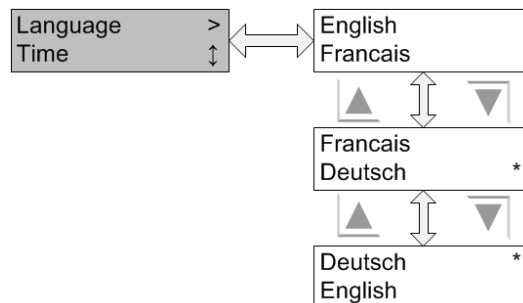

5.10.6 Time

The time can be set here.

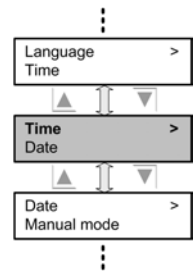

5.10.6.1 Timesetting

In the Time menu, the set time is displayed and changed where required in the 24-hour clock mode.

The time is used to enter the alarm times in the alarm memory and for all timer functions.

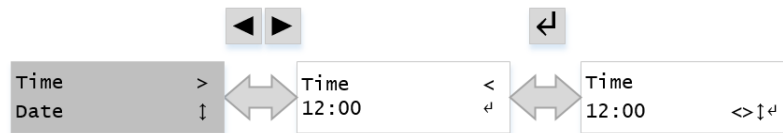

5.10.7 Date

The date can be set here.

The date is displayed in the form DD.MM.YY and can be changed if necessary.

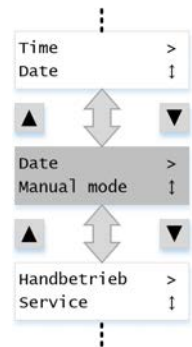

5.10.7.1 Set date

The date is used to enter the alarm times in the alarm memory and for all timer functions (night reduction etc.)



5.10.8 Manual mode

Manual mode is used to operate the system's water inlet valve and drainage valve by hand.

Manual mode does not depend on DI1 enabling, has the highest priority and switches off all other control modes.

The prerequisite for switching on the manual mode is the set external temperature. This must be above the frost temperature, as otherwise the manual mode cannot be switched on. Wetting is not permitted in the manual mode without recording the external temperature.

Active manual mode is saved permanently, in other words it is active again even after switching off and on.

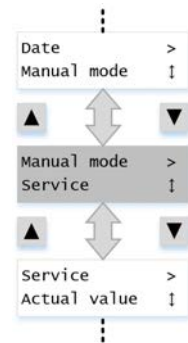

5.10.8.1 Manual mode settings

When manual mode is activated, the water valve opening (0..10V) can be changed manually in the valve control value menu. This can be activated in the draining menu.

The * indicates whether manual mode ON or OFF is active.

Manual mode ON / OFF

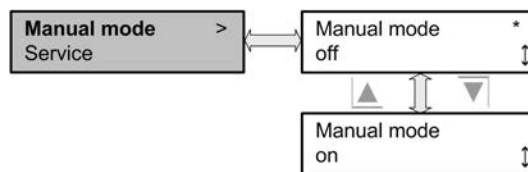

Manual mode – valve control value/draining

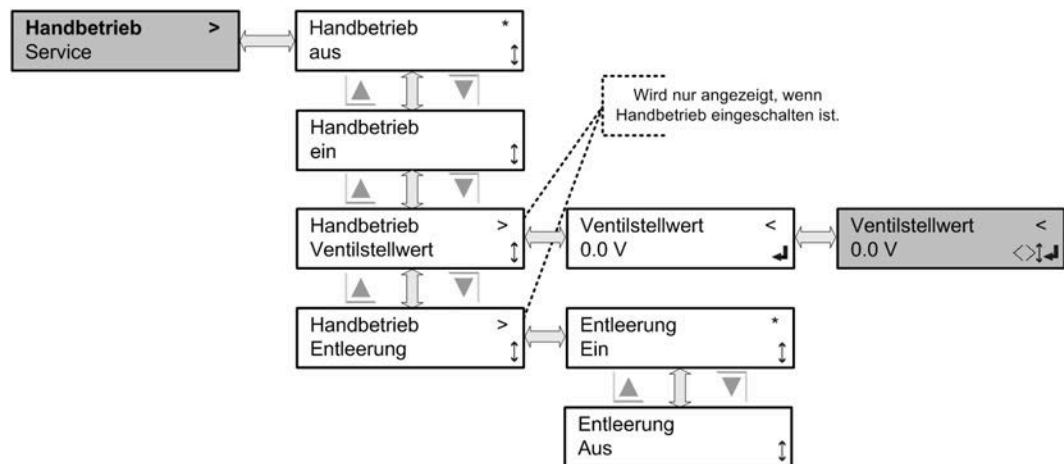

5.11 Service

The Service menu is accessible only with a password, which is the first thing you are asked for.

The password is **3795**.

Once the password has been accepted, the Service menu appears.

The password is valid for 15 min. and is not asked for again during this time.

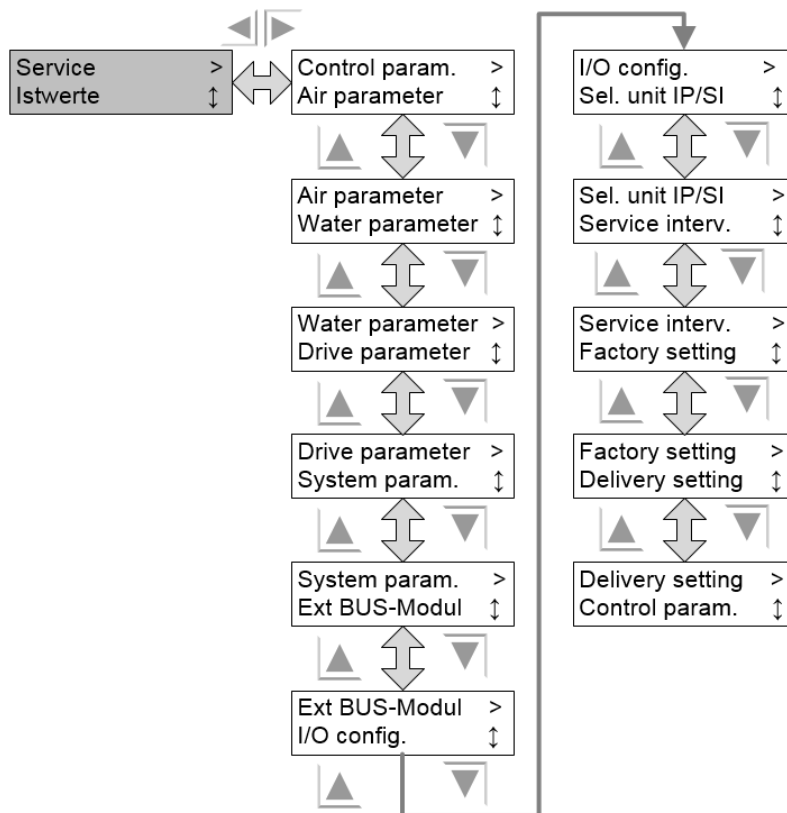
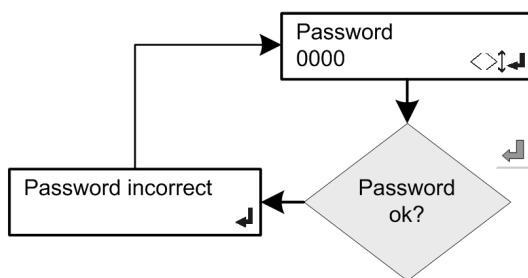
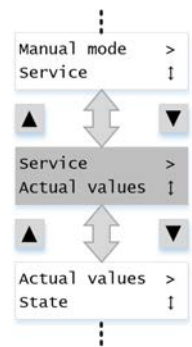

5.11.1 Control parameters

In this menu, you configure the control parameters of the digital PID controller (proportional, integral, derivative controller).

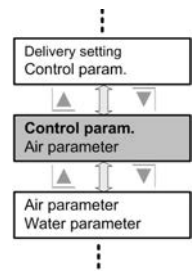

5.11.1.1 Control parameter Kp, Ti

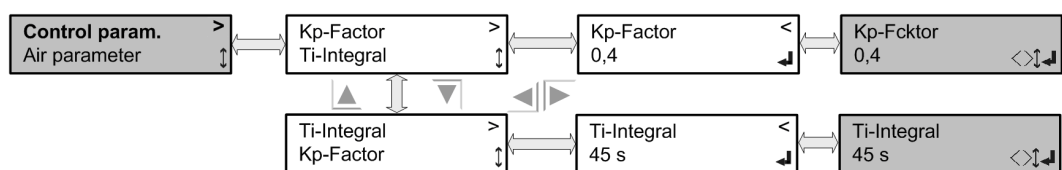

The Kp factor can be entered in a range from 0.1 to 10.0 with one decimal place. The Kp factor specifies the control amplification. It is the proportion of the control path following the input signal.

The Ti reset time changes the control value in the set time by the value specified by the proportional factor.

The max. flow in the water parameters sub-menu is required as a control parameter.

Example: With a max. flow of 1000 l/h a deviation of 100 l/h is equal to a control deviation of 10%. With an unchanged control deviation of 10% and $K_p = 0.4$ the Ti control signal = 45s is increased by 4%.

5.11.2 Air parameters

The air parameters are configured in this menu.

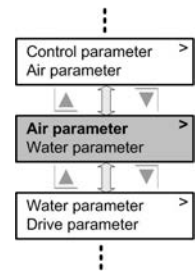

5.11.2.1 Airflow volume and air speed

The maximum airflow volume and the maximum air speed must be entered to calculate the required water volume.

Note: You will find this data on the GPC unit construction sheet.

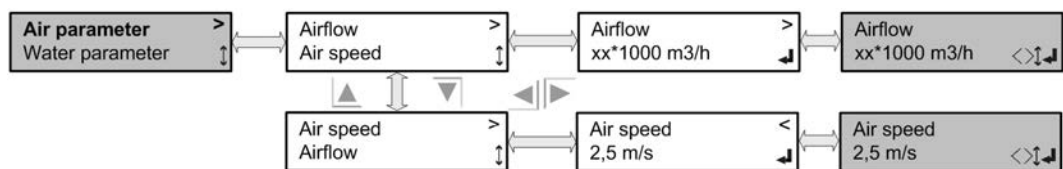

5.11.3 Water parameters

The water parameters are configured in this menu.

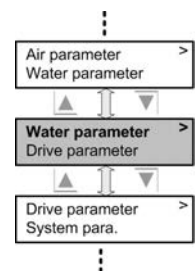

5.11.3.1 Max. flow

The maximum flow must be set so that the control deviation and the control variable of the water valve can be calculated.

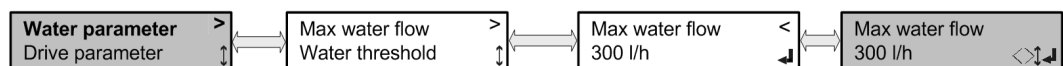

5.11.3.2 Base value

The wetting is only released when the calculated water volume is above the base value.

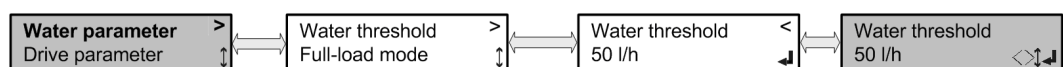

5.11.3.3 Full load mode

The full load mode is activated at this set limit. If the fans' speed is below the set limit value, the efficiency mode is active, provided it was switched on in the Parameters → Efficiency mode menu. If the efficiency mode is switched off, the wetting is performed with the calculated water volume, but without any costs consideration.

If, when configuring the digital inputs (see [I/O configuration, page 56](#) → DIx), you specified full load mode, this will not be activated until the DIx input is switched and the speed has reached the threshold value for full load mode.

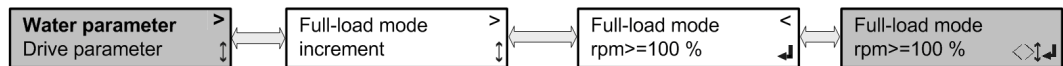

5.11.3.3.1 Increment, delay, max. H2O supply

If the calculated water volume is not sufficient in the full load operation, the water volume is increased incrementally with a delay up to the maximum water issue rate. By increasing the water issue rate, a part of the water flows unevaporated, but this means that in full load a higher wetting capacity of some 10% can be achieved.

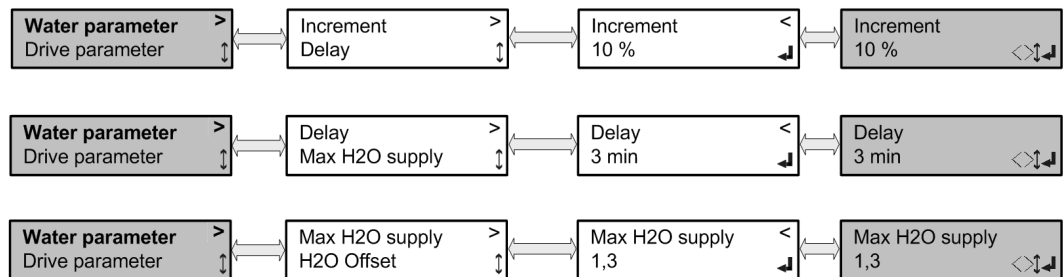

5.11.3.4 H2O offset

The H2O offset is a correction factor on the water volume calculated by the controller. With a factor of >1 the calculated water volume can be increased, and reduced with a factor of <1.

Note: The water volume is regulated in efficiency mode according to cost consideration points. Depending on the type of system and operating situation, it is possible that the water admission flow of the HydroPad is very low and it is also possible that the water will drain off unevaporated.



5.11.3.5 Cleaning cycle

The cleaning cycle for the pads is a system operating state in which the water input valve is 100% open. This makes the system more efficient because the pads are thoroughly soaked and cleaned in specific intervals. When transitioning from dry to humidified operation the system first carries out a cleaning cycle for the pads. This function is active as a default. It can be deactivated at any time via the Service menu. The cleaning cycle is normally carried out completely, even if the conditions for humidification are no longer met, but it will be aborted if the controller's Enable is withdrawn or if the humidification condition "Ambient temperature" no longer applies. For the cleaning cycle, both a duration for humidification and an interval (between cleaning cycles) can be specified via the following menu.

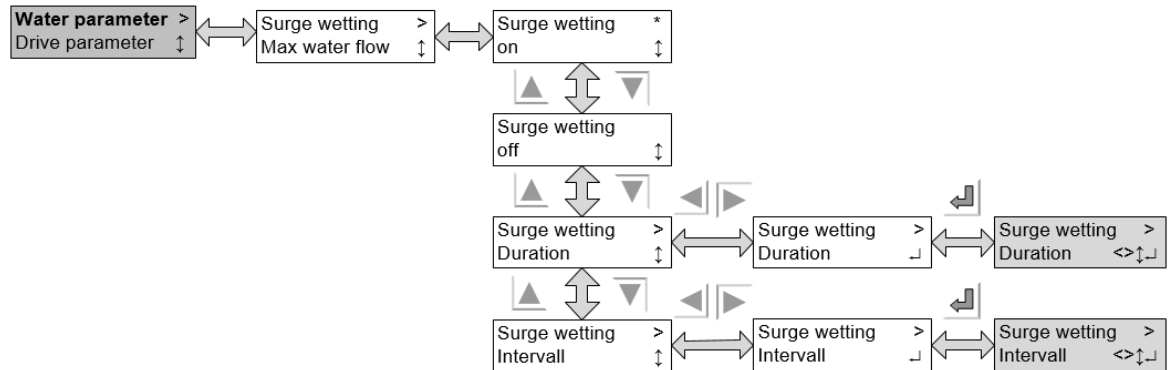

5.11.4 Drive parameters

The drive parameters are configured in this menu.

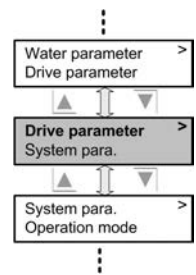

5.11.4.1 Type of speed control: EC/FU/leading edge

The type of speed control must be entered for the efficiency calculation.

- EC fans → EC
- AC fans → FU GMM sincon
GMM f-drive
- GDRD leading edge

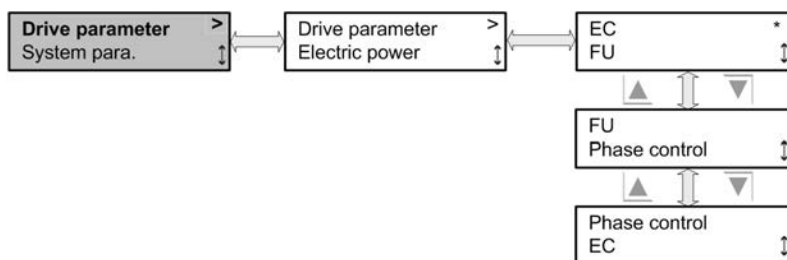

5.11.4.2 Electric power

The entire nominal power of the fans must be entered for the costs calculation.

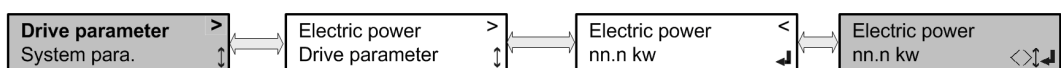

5.11.5 System parameters

The system parameters are configured in this menu.

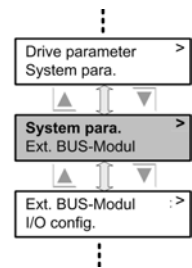

5.11.5.1 Fault report

Water fault report:

The max. deviation and the testing period are set here.

If the control deviation is above the set max. deviation for the entire testing period, a fault report is made.

Setpoint - actual value > max. deviation → Fault

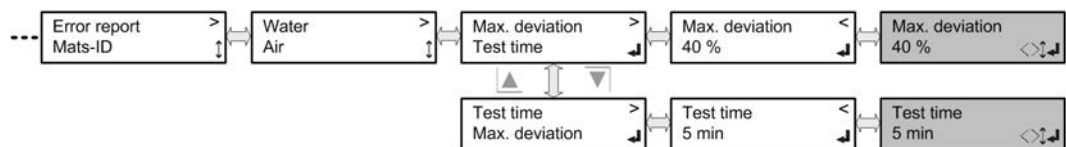

Air fault report:

The max. pressure loss over the HydroPads and heat exchanger coil is set on the differential pressure switch. If the pressure loss is above the max. permissible pressure loss for the entire testing period, there is a fault report.

Note: Take pressure loss from the GPC. If a fault occurs it is recommended you clean the heat exchanger and the HydroPads.



5.11.5.2 Matt ID

The matt ID is set here.

1 = Jäggi

2 = Güntner

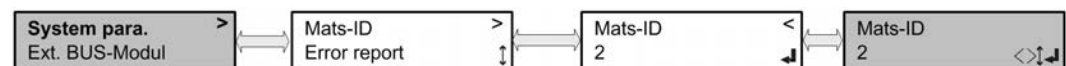

5.11.6 External bus module

If an external bus module is connected, the communication parameters for the module in question can be set in this menu. In addition to the fieldbus address, the baud rate and framing can also be pre-set additionally in the case of a Modbus module.

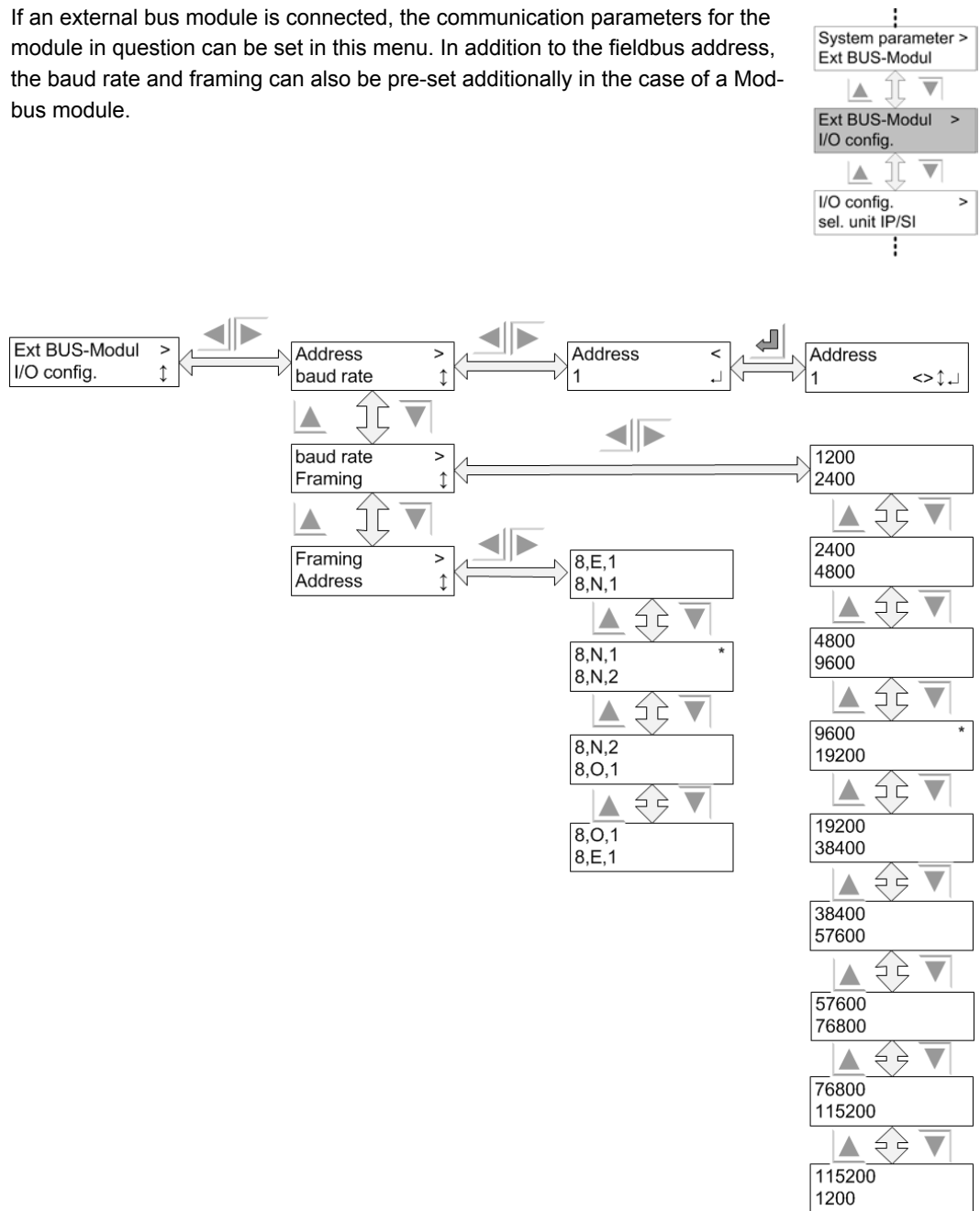

NOTICE

Turn off the power to the GHM + bus module after every address change. Only then will the new addresses be accepted.

5.11.7 I/O configuration

The configuration of the inputs and outputs can be adjusted via this menu.

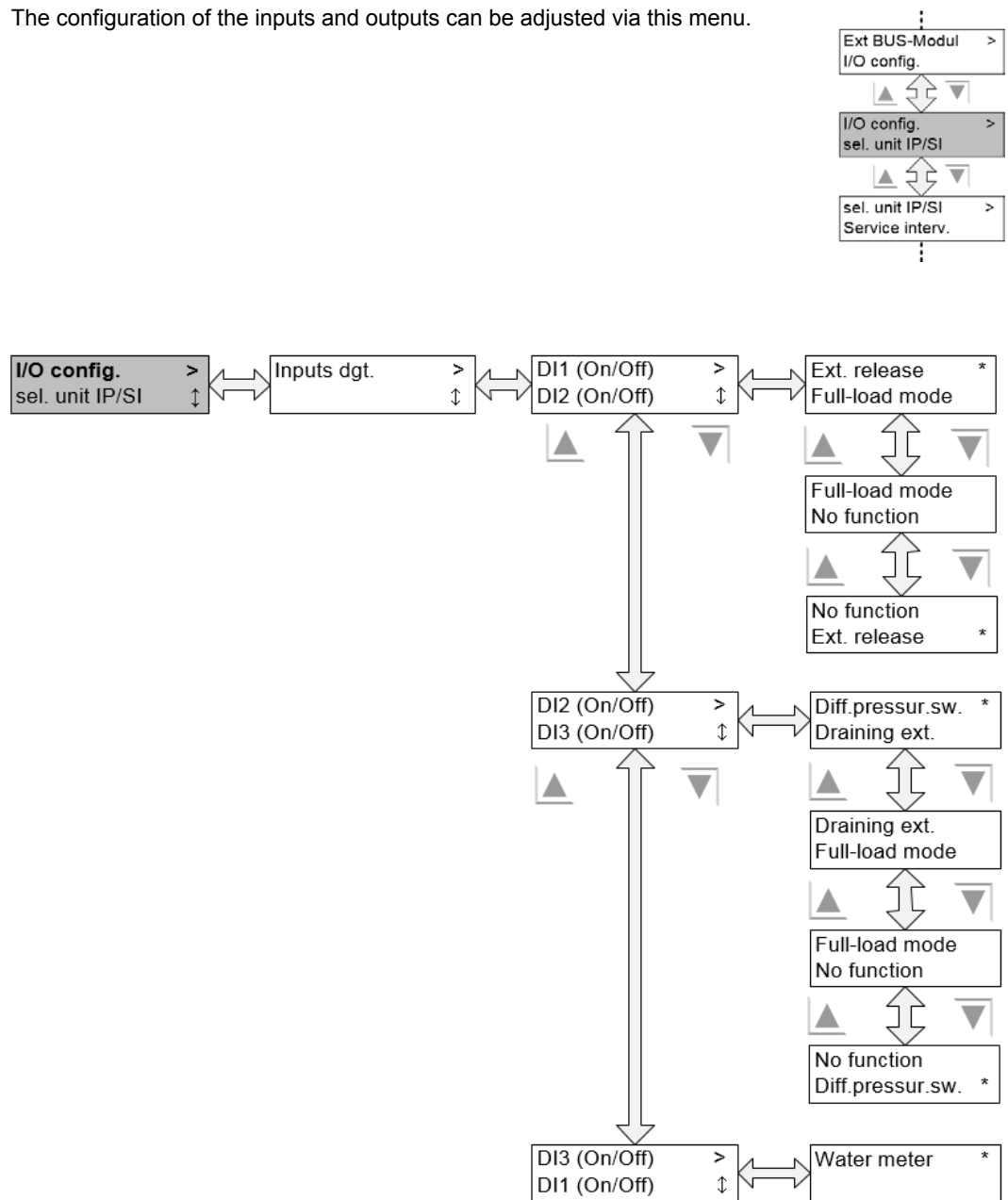

5.11.8 SI/IP selection

The units system can be selected here.

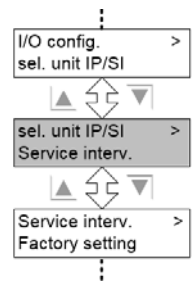

5.11.8.1 SI/IP units system

Unit selection for temperature and relative humidity.

International units →

SI (Système international d'unités)

Anglo-American units →

IP (Imperial System)

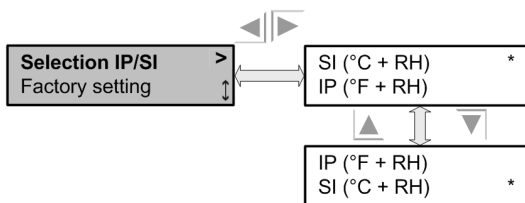

The selected unit of measurement is shown with a *.

5.11.9 Service interval

This is where you can specify the Service interval parameters.

The service interval functionality handles the task of informing the operator when system maintenance is due. The menu enables you to configure the alarm and the intervals for necessary maintenance.

In the “Warnings” submenu you can enable or disable warnings both for exceeding the maximum operating hours and for exceeding the intervals between service call-outs.

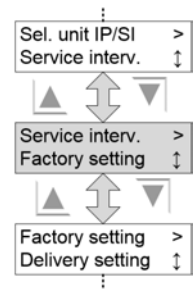

The interval prior to a service call-out can be specified either from the menu “Maximum operating hours” or from “Interval duration”. The difference between the two intervals is that the period of time specified in the menu “Maximum operating hours” maps the time during which the system humidifies. The “Interval duration” menu is used to set the time during which the system’s operating hours are counted, irrespective of whether the system humidifies or not.

The submenu “Warning from” gives you the option of specifying percentage values as a threshold. When the operating hours or the interval duration reach this threshold, a PRIO 2 pre-warning with an appropriate message is displayed in the Info menu. This pre-warning and the message itself can be acknowledged with the Enter key. This functionality is intended to alert the operator to the scheduled system maintenance or pad replacement.

If the specified interval or the specified maximum operating hours are exceeded, a PRIO 2 warning with an appropriate message will be displayed in the info menu. This warning is intended to alert the operator to the scheduled system maintenance.

Once the maintenance has been carried out, the active warning can be reset by using the "Reset service" menu to reset the Relative operating hours.

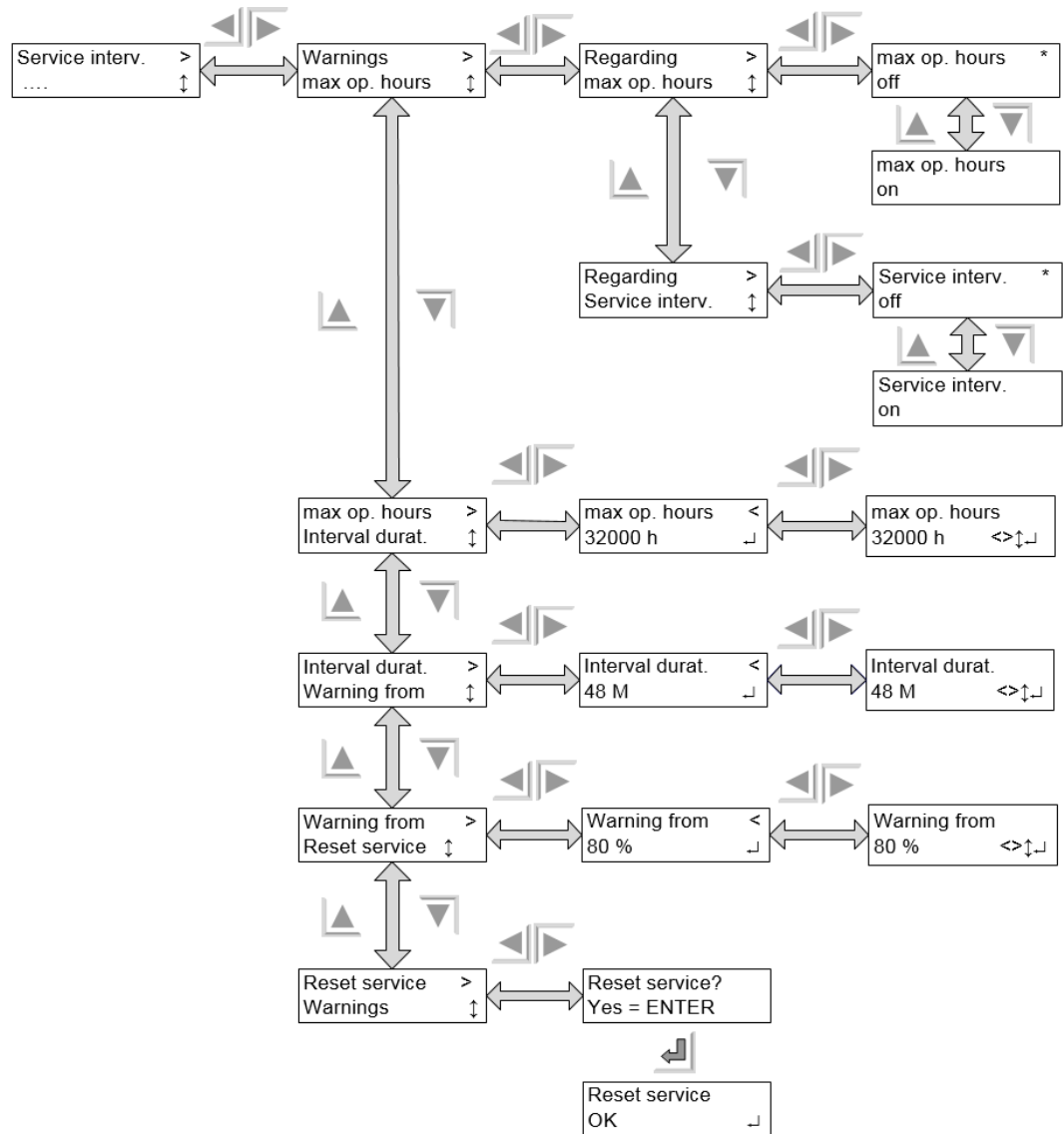

5.11.10 Factory setting

The control can be reset to factory settings here.

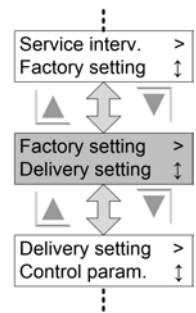

5.11.10.1 Control reset (factory setting)

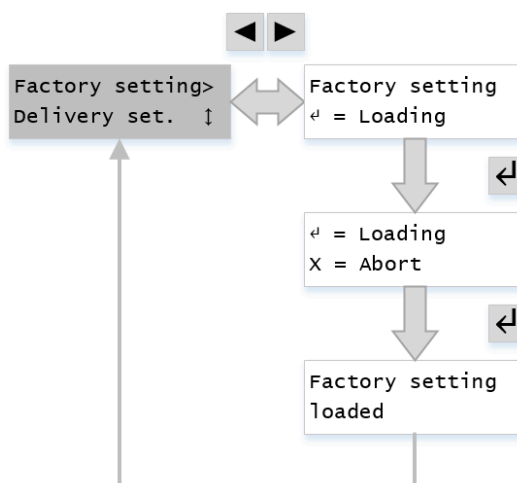

NOTICE

Any changes made locally will be deleted. Factory commissioning values will be retained. The control functions are reset to their default values.

See [Factory setting, page 66](#)

5.11.11 Delivery condition

The control can be reset to delivery condition here.
Commissioning is then not necessary.

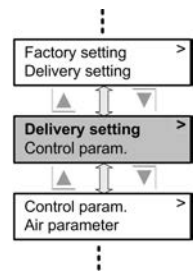

5.11.11.1 Control reset (delivery condition)

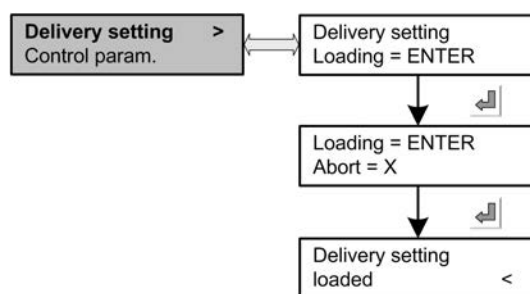

NOTICE

Any changes made locally and the **commissioning values** will be cleared. Once this function has been completed, a completely new factory commissioning must be carried out.

6 Faults and troubleshooting

6.1 General notes

Most faults that occur during commissioning are due to wiring faults or defective sensors. Only in the rarest of cases is the humidification controller itself defective. Check the following points before ordering a replacement:

Status info menu:

- Is a fault displayed in the info menu?
- If the message "Equipment failure" is displayed, there is a fault in the wetting controller.

Please check if the voltage supply is present on the wetting controller.

- For other fault reports, see Table [Fault reports and warnings, page 67](#)

TEST POINT 2:

Sensor connection:

- Is the sensor correctly connected? Cf "Sensor connection" section
- Sensor OK? (Measure! Pressure: 4-20mA, Temp.: 4-20mA1.2-2.7k, default signal: 0-10V)
- Are the sensor cables laid in the immediate vicinity of mains or motor cables? Consider increasing the distance!
- Are the sensor cables shielded? If not – swap for shielded cables!
- Is the shielding applied unidirectionally on the controller?

Fuses:

- Is the fuse protection on the controller supply line OK?

7 Technical data

7.1 Dimensions of component -Dimensions / weight

Dimensions of GRCpad.1

You will find the housing dimensions below. All dimensions are given in millimetres.

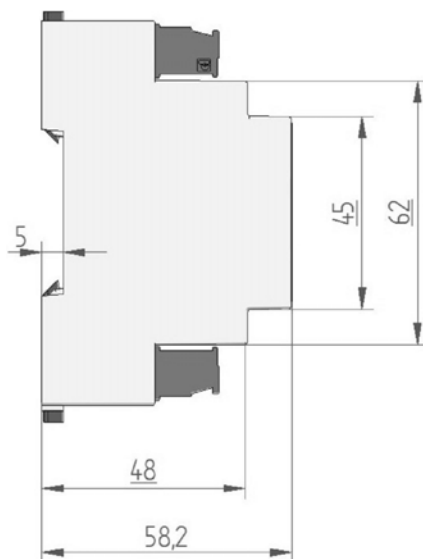
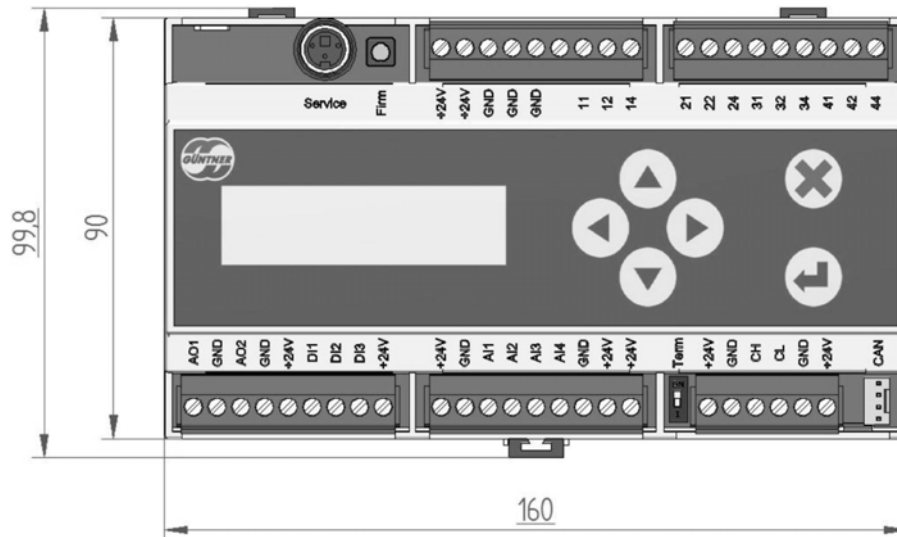

Dimensions of casing GRCpad.1

Weight:
approx. 340 g

8 Electrical properties of the component

Electrical properties of GRCpad.1				
	Min	Type	Max	Unit
Power supply	21	24	30	V
Current consumption		80	250 ¹	mA
Digital inputs				
High level	15	24	30	V
Low level	-3	0	5	V
Relay outputs				
Voltage DC		24	30	V
Voltage AC			250	V
Current resistive load 24V DC/250V AC			1	A
Current inductive load 24V DC/250V AC			1	A
Switch cycles, mechanical	1*10 ⁶			Switching cycles
Switching cycles, electrical	1*10 ⁵			Switching cycles
Voltage input				
Dielectric strength	-24		30	V
Measuring range	0		12	V
Resolution			10	bit
Error			1	% ²
Input resistor:		230		kΩ
Current input				
Dielectric strength	-24		30	V
Measuring range	0		21	mA
Resolution			10	bit
Error			1	% ²
Input resistor: (without protective circuit)		130		Ω

Electrical properties of GRCpad.1

	Min	Type	Max	Unit
Voltage output				
Voltage range	0		10	V
Load resistance		>=100		kΩ
Resolution			10	bit
Error			2.5	% ²
Short circuit protection	Yes			
Potential separation	No			
Temperature input				
Dielectric strength	-24		30	V
Measuring range	-30		100	°C
Resolution			10	bit
Precision			3	% ²
CAN bus				
Dielectric strength	-24		24	V
Transmission rate		125		kbit/s
Galvanic separation	No			

Electrical properties of GRCpad.1

1. The maximum current consumption includes supplying two connected pressure transmitters and one connected temperature sensor.
2. Of the appropriate range

9 Factory setting

Wetting:	ON from rpm > OFF from rpm < ON from T >	60% 50% 22 °C
Draining:	Standstill time > External temp. <	24 h 6 °C
Efficiency mode:	Mode on/off Water costs Power costs	OFF 2.00 €/m ³ 0.22 €/kWh
Control parameters:	Kp factor Ti factor	0.4 45 s
Water parameters:	Base value Full load mode Increment Delay Max. Water supply factor Offset factor Cleaning cycle Cleaning cycle duration Cleaning cycle interval	50 l/h 100 % 10 % 3 min 1.3 1 ON 5 min 60 min
Water fault:	Max. deviation Testing period	40% 5 min
Air fault:	Testing period	5 min.
Unit:		SI (°C + RH)

Factory setting

10 Fault reports and warnings

The table shows which signal relay (**PRIO 1** or **PRIO 2**) is tripped with which message on the display.

Messages /warnings on the display	PRIO 1	PRIO 2	Explanation
Start-up, please wait			The system was started
Start-up, please wait			Restart, internal software error
Temp. sensor / AI1 fault	x		Sensor not connected or cable is broken
Wet. Sensor / AI2 fault		x	Sensor not connected or cable is broken
U > 12V / AI4 fault		x	Voltage too high
GMM NOK	x		GMM EC is defective, has no power, has a broken cable or the CAN bus is not correctly terminated
Hydraulics NOK		x	The valve is defective, the tubes are dirty or the water pressure is too low.
Air supply NOK		x	Differential pressure gauge has detected dirt.
Service interval / in xx m		x	A preliminary warning that the system is due for servicing in xx months time.
Service interval / necessary		x	The system needs servicing
Service operating hours / in xxx h		x	A preliminary warning that the system is due for servicing in xxx hours time.
Service operating hours / exceeded		x	The system needs servicing
Reset Service			The relative operating hours and all warnings have been reset

[Fault reports/warnings on the display](#)

11 Troubleshooting tips

Error	Possible cause, suggested solution
Hydraulics NOK:	<ul style="list-style-type: none"> - Water supply turned off → Check - Not enough pressure to bring up necessary water quantity (check water pressure in water system) - Control valve defective or blocked - Tubes dirty or furred up → Replace
Air supply NOK:	Differential pressure switch tripped Clean →HydroPads, heat exchanger
Sensor error:	Measure sensor (resistance measurement < 800Ω, or current < 2mA or >22mA)
Draining not possible:	Drain valve defective or blocked → Check for mechanical defect caused by permanent magnet

[Error search - tips](#)

12 Index

A	
Actual values.....	35, 35
Air fault report.....	54
Airflow volume.....	50
Air parameters.....	50
Air speed.....	50
Alarm memory.....	43
Alarms.....	42
Ambient temperature.....	35
Analogue inputs.....	31
Analogue outputs.....	33
B	
Base value.....	50
Basic menu.....	34
Bus module.....	38
Bus module, external.....	55
C	
cleaning cycle.....	39, 52
cleaning cycle for the pads.....	52
Commissioning.....	9
Commissioning menu.....	10
Configuration.....	26
Connections GRCpad.1.....	18
Construction of the GHM pad.....	12
Control inputs.....	28
Control parameters.....	49
Control reset (delivery condition).....	61
Control reset (factory setting).....	60
D	
Date.....	46
Delay.....	51
delivery address.....	2
Delivery condition.....	61
Differential pressure switch.....	29
Dimensions of GRCpad.1.....	63
Display.....	21
Draining.....	36, 40
Draining – external temperature.....	40
Draining Standstill time.....	40
Drive parameters.....	53
E	
EC/FU/leading edge.....	53
Edit mode.....	24
Efficiency mode ON/OFF.....	41

Efficiency mode – water costs.....	41, 41
Electrical properties of GRCpad.1.....	64
Electric power.....	53
Enable.....	37
Equipment failure.....	62
Error search - tips.....	68
External air humidity.....	35
External bus module.....	55
External temperature.....	35, 40, 40
F	
Factory setting.....	60
Fan speed.....	35
Fault reports.....	67
Faults – General notes.....	62
Full load mode.....	51
Functional description of GRCpad.1.....	13
Fuses fault.....	62
G	
Geodetic height.....	41
GRCA.....	17
Group alarm.....	27
H	
H2O offset.....	51
Hardware and software versions.....	38
Humidity sensor connection.....	31
I	
Increment.....	51
Info menu.....	21
Installation / Operating conditions GRCpad.1.....	16
interval.....	58
L	
Language.....	44
Language selection.....	44
liability.....	2
M	
Manual mode.....	47
Manual mode ON/OFF.....	47
Manufacturer address.....	2
Matt ID.....	54
Max. flow.....	50
Max. H2O supply.....	51
O	
operating hours.....	38, 38
Operating menu.....	34
Operating mode.....	8, 38

Operation.....	21, 23
Output (11/12/14).....	27
Output (21/22/24).....	27
Output (31/32/34).....	27
Output (41/42/44).....	27
P	
Parameters.....	40
Power costs.....	41
S	
Safety instructions.....	2
Selection mode.....	25
Sensor connection fault.....	62
Service.....	48
service call-out.....	39, 39
Service interval.....	58
Service Number.....	7
Set date.....	46
SI/IP selection.....	57, 57
Signalling outputs.....	27
Speed type.....	53
Standstill time.....	40
Status.....	37
System parameters.....	54
T	
Temperature sensor connection.....	31
Time.....	45
Time setting.....	45
U	
Units system.....	57
Use according to the intended purpose.....	2
V	
Valve control value.....	36
Voltage signal 0#10V.....	32
W	
Warnings.....	67
Warranty.....	2
Water costs.....	41
Water fault report.....	54
Water flow.....	36
Water flow meter.....	30
Water meter.....	39
Water parameters.....	50
Water volume.....	36

Wetting – external temperature.....	37, 40
Wetting – frost protection.....	37
Wetting OFF.....	37, 40
Wetting ON.....	37, 40



13 Picture index

img. 1:	Construction of the humidification controller GHM pad.....	12
img. 2:	Short description of the wetting controller GHM pad.....	13
img. 3:	Accumulated annual temperature.....	14
img. 4:	Controller GRCpad.1.....	17
img. 5:	Floating signalling outputs.....	27
img. 6:	Connection of external enable contact +24V – D11.....	28
img. 7:	Differential pressure switch connection.....	29
img. 8:	Water quantity meter connection.....	30
img. 9:	Temperature sensor + humidity sensor connection.....	31
img. 10:	Communication between speed controller and wetting controller.....	32
img. 11:	Analogue outputs.....	33
img. 12:	Dimensions of casing GRCpad.1.....	63

14 Table index

tab. 1:	Configuration table GRCpad.1.....	26
tab. 2:	Electrical properties of GRCpad.1.....	64
tab. 3:	Factory setting.....	66
tab. 4:	Fault reports/warnings on the display.....	67
tab. 5:	Error search - tips.....	68