

Data sheet GFQD.1



www.guentner.de

Contents

1	GFQD.1	3
1.1	Functional description.....	3
1.2	Configuration table.....	3
1.3	Connections.....	3
1.4	GFQDxxx.1 LEDs.....	5
1.5	Electrical properties of.....	6
1.6	Installation / Operating conditions.....	6
1.7	Dimensions / Weight.....	7

1 GFQD.1

1.1 Functional description

The GFQD.1 (frequency converter) is used for variable rotary field generation. Depending on the control value, the output frequency is controlled from 0 Hz through to the mains frequency. The GFQD is controlled by the Güntner controller GRCF.1 via the CAN bus.

The AC fans are connected via a sinusoidal filter to the output of this frequency converter. The fan speed matches the output frequency, from 0 rpm up to the maximum speed.

1.2 Configuration table

Type	ERP no.	Power [kW]	Current [A]
GFQD010.1	5204114	0.375	1.0
GFQD010.1 UL	5204115	0.375	1.0
GFQD022.1 UL	5204116	0.75	2.20
GFQD041.1 UL	5204117	1.5	4.10
GFQD057.1 UL	5204118	2.2	5.70
GFQD078.1 UL	5204119	3	7.80
GFQD100.1 UL	5204120	4	10.00
GFQD140.1 UL	5204121	5.5	14.00
GFQD170.1 UL	5204122	7.5	17.00
GFQD240.1 UL	5204123	11	24.00
GFQD320.1 UL	5204124	15	32.00
GFQD450.1 UL	5204125	22	45.00

1.3 Connections

The frequency converters are supplied with mains voltage. The frequency converters' wiring is defined in the switch cabinet's circuit diagram. It must be ensured that a clockwise-rotating field is connected, otherwise there may be an abrupt change of direction when you activate a bypass switch!

Power connection

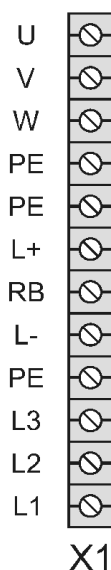

Control signals

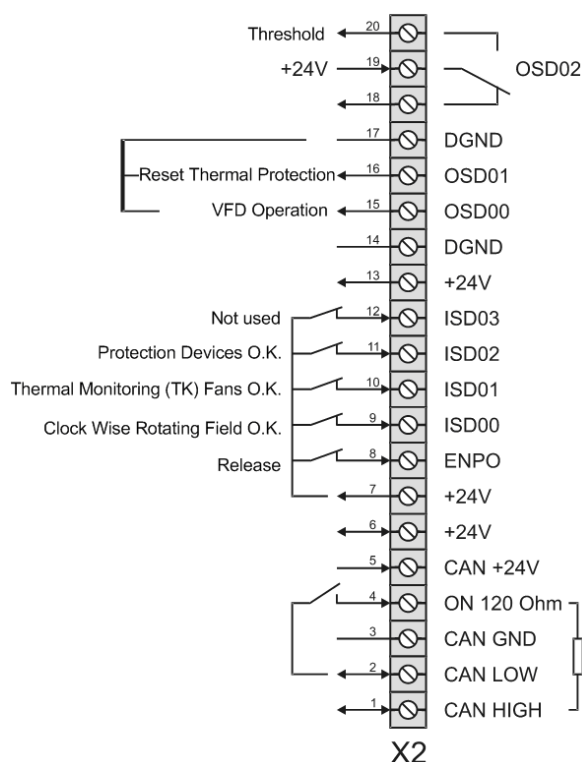

Power connection → Motor operation

The following must ALWAYS be observed when operating the frequency converter with several fans:

Individual fans can be switched off during the operation without restriction, for example by activating a thermocontact.

When switching motors on during operation, it must be ensured that the switch-on power is not higher than the frequency converter peak power. It is helpful if the frequency converter load is >40%. This 40% basic load supports the frequency converter's output voltage while switching on.

ADVICE

While being switched on the motor must not be operated in the field suppression range, as it would otherwise have to start with reduced starting torque.

1.4 GFQDxxx.1 LEDs

	H1	H2	H3
	ERR / WARN (red)	READY (yellow)	POWER (green)
device state	red LED (H1)	yellow LED (H2)	green LED (H3)
Supply voltage located	○	○	●
Operational (ENPO set)	○	●	●
Active / self-tuning active	○	✱	●
Warning	●	●	●
Error (see blinking Code)	✱	○	●
	○ LED off	● LED on	✱ LED blinking

The red LED is used to signal the following fault situations

Red LED flash code	Display Display	Cause of the fault
1x	E-CPU	Collective fault message
2x	E-OFF	Undervoltage switch-off
3x	E-OC	Overcurrent switch-off
4x	E-OV	Overvoltage switch-off
5x	E-OLM	Motor overloaded
6x	E-OLI	Unit overloaded
8x	E-OTI	Cooling unit temperature too high
9x	E-PLS	Plausibility error, parameters or programme flow
10x	E-PAR	Defective parameters
11x	E-FLT	Floating point error
12x	E-PWR	Power unit unknown
13x	E-EEP	Defective EEPROM

Flash code (number of successive impulses)

These and other fault messages of the GFQDxxx.1 output stages are forwarded to the GRFC.1 controller, displayed there on the display and also saved in the alarm history.

1.5 Electrical properties of

Electrical properties of GFQD.1					
Type	ERP no.	Power [kW]	Current [A]	Size	Power loss [W]
GFQD010.1	5204114	0.375	1.0	BG2	30
GFQD010.1 UL	5204115	0.375	1.0	BG2	30
GFQD022.1 UL	5204116	0.75	2.20	BG2	70
GFQD041.1 UL	5204117	1.5	4.10	BG2	112
GFQD057.1 UL	5204118	2.2	5.70	BG2	148
GFQD078.1 UL	5204119	3	7.80	BG3	162
GFQD100.1 UL	5204120	4	10.00	BG3	207
GFQD140.1 UL	5204121	5.5	14.00	BG4	268
GFQD170.1 UL	5204122	7.5	17.00	BG4	325
GFQD240.1 UL	5204123	11	24.00	BG5	400
GFQD320.1 UL	5204124	15	32.00	BG5	510
GFQD450.1 UL	5204125	22	45.00	BG6	610

Mains voltage 3 x 400V(-15%) ... 3 x 460V(+10%)

Frequency 50/60 Hz +/-10%

1.6 Installation / Operating conditions

The frequency converter is mounted vertically on a galvanised mounting panel. This ensures there is sufficient air convection in the GFQD.1.

The frequency converter must be adequately earthed.

Feature		GFQD010.1 ... GFQD450.1
Climatic conditions	In operation as per EN 61800-2 IEC 60721-3-3 Class 3K3	+5 to +40°C (2) at relative humidity from 5 to 85% without condensation
	In storage as per EN 61800-2 IEC 60721-3-1 Class 1K3 + 1K4	-25 to +55°C (3) at relative humidity 5 to 95%
	In transit as per EN 61800-2 IEC 60721-3-2 Class 2K3	
Protection rating	Unit	IP20 (connector terminals IO00)
	Cooling concept	IP20 convection
Contact protection		BGV 3

Feature		GFQD010.1 ... GFQD450.1
Installation height		Up to 1000 m above sea level, above 1000 m above sea level with power reduction, max. 2000 m above sea level

1.7 Dimensions / Weight

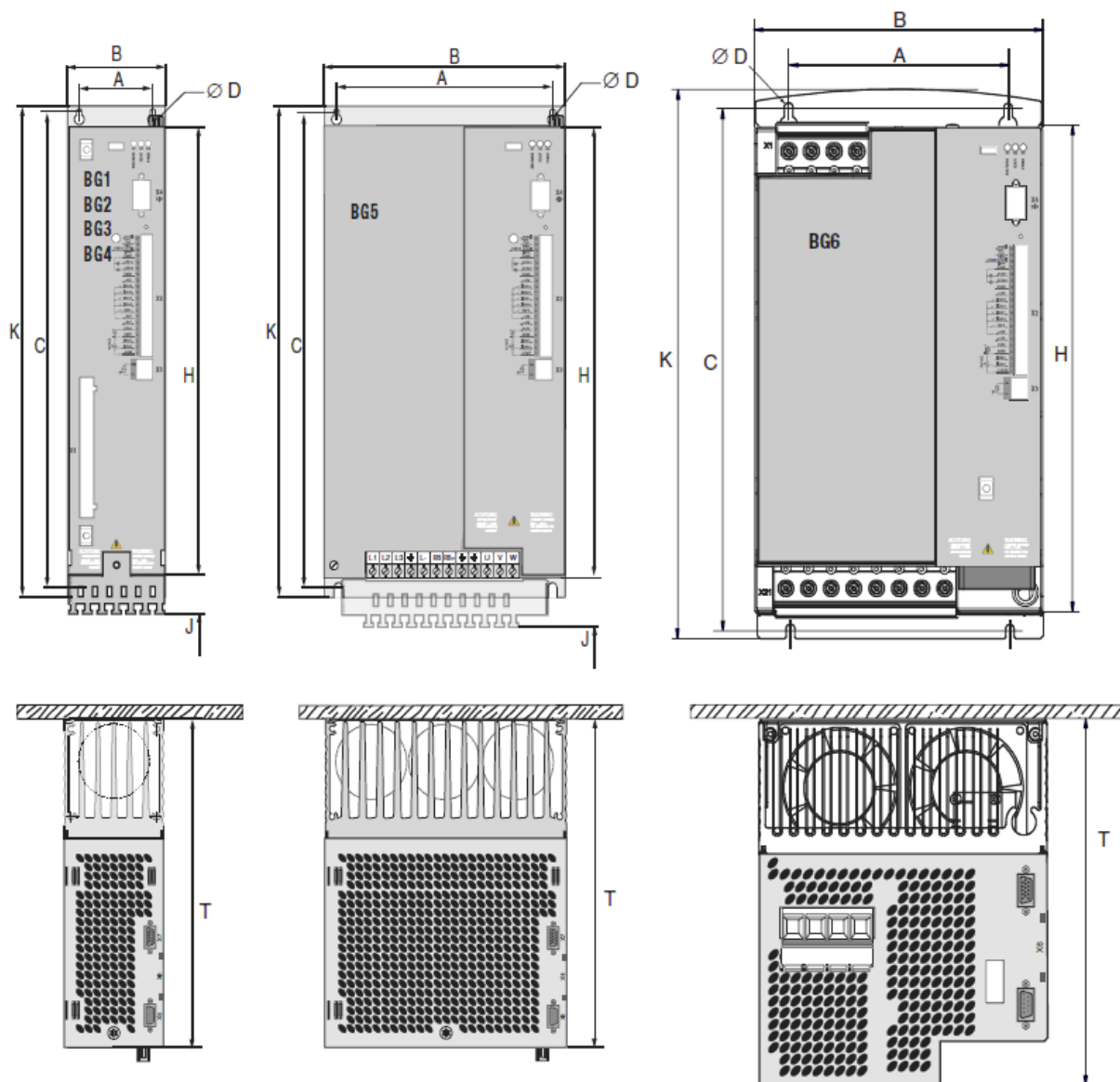

Dimensions of GFQD.1

	BG2	BG3	BG4	BG5	BG6
Weight [kg]	3.5	4.4	6.5	7.2	13
W width [mm]	70	70	120	170	190

	BG2	BG3	BG4	BG5	BG6
H height [mm]	247	300	300	300	348
D depth [mm]	220	218	218	218	230
A [mm]	40	40	80	130	150
C [mm]	260	320	320	320	365
D # [mm]	4.8	4.8	4.8	4.8	5.6
J [mm]	45	45	45	55	-
K [mm]	270	330	330	330	382