

Installation instructions (original)

Transportation | Assembly | Operation | Maintenance



Product line:	CO ₂ aircoolers
Series description:	wall/ceiling evaporators
Series:	CPGHN.2

www.guentner.de

Contents

1	Important basic information.....	5
1.1	Safety instructions.....	5
1.1.1	Observing operating instructions.....	5
1.2	Importance of the EN 378 series of standards – refrigeration systems and heat pumps – safety-related and environmental requirements.....	5
1.3	Responsibilities.....	5
1.3.1	Manufacturer's responsibilities.....	5
1.3.2	Responsibilities of the system's installer.....	6
1.3.3	Owner or operator responsibilities.....	6
1.4	Legal notes.....	7
1.5	Operating instructions.....	7
1.5.1	Scope.....	7
1.5.2	Set-up and other applicable documents.....	7
1.6	Conventions.....	8
1.6.1	Typographical conventions.....	8
1.6.2	List of abbreviations.....	8
1.7	Conventions for safety signs and notices.....	9
1.7.1	General safety signs and their meaning in these operating instructions.....	9
1.7.2	Warning symbols and their meaning in these operating instructions.....	9
1.7.3	Prohibitory signs and their meaning in these operating instructions.....	10
1.7.4	Mandatory signs and their meaning in these operating instructions.....	10
2	Safety.....	12
2.1	Labelling on the unit:.....	12
2.1.1	Safety signs on the unit.....	12
2.1.2	Other signs and notes on the unit.....	15
2.2	Basic safety notices.....	18
2.2.1	How to act in an emergency.....	18
2.2.2	Personnel, care requirements.....	18
2.3	Proper intended use.....	19
2.3.1	Proper intended use.....	19
2.3.2	Operating conditions.....	19
2.3.3	Improper use.....	20
2.4	Mechanical residual hazards.....	22
2.4.1	Fins, sharp unit corners and edges.....	22
2.4.2	Flap down drip tray.....	22
2.4.3	Fans.....	22

2.4.4	Hinged side plates.....	23
2.5	Electrical residual hazards.....	24
2.6	Thermal residual hazards.....	25
2.6.1	Frostbite hazard.....	25
2.7	Residual hazards due to carbon dioxide (CO₂).....	25
2.8	Residual hazards caused by vibrations.....	27
2.9	Residual hazards caused by pressurised parts.....	27
2.10	Residual hazards caused by defective installation.....	28
2.11	Residual hazards with break during operation.....	29
2.12	Residual hazards caused by escaping objects or liquids.....	30
2.13	Combined residual hazards.....	30
2.13.1	Removable side plates/.....	30
2.14	Residual hazards with disposal.....	30
3	Technical data.....	32
3.1	Unit.....	32
3.2	Fans.....	32
4	Set-up and function.....	34
5	Fan motor.....	35
6	Transportation and storage.....	36
6.1	Safety.....	36
6.2	Transportation and storage.....	36
6.3	Storage before installation.....	37
7	Set-up and start-up.....	39
7.1	Safety.....	39
7.1.1	Safety instructions for set-up and start-up.....	39
7.1.2	System-side safety requirements.....	40
7.1.3	Customer-side safety precautions.....	41
7.2	Requirements at the set-up point.....	42
7.3	Unpacking the unit.....	44
7.4	Installation.....	46
7.4.1	System-side requirements for stress-free installation.....	46
7.4.2	Mounting the unit.....	49
7.4.3	Notes on mounting fan swivel unit (option).....	49
7.5	Notes on connecting the unit.....	53
7.5.1	Connecting the drain line to the drip tray.....	53
7.5.2	Connect the unit to the system.....	54
7.5.3	Unit electrical connection and protection.....	55
7.6	Perform acceptance test.....	56
7.7	Test readiness for operation.....	57
7.8	Putting the unit into operation for the first time.....	58

8	Operation.....	59
8.1	Safety.....	59
8.2	Putting the unit into operation.....	59
8.3	Taking the unit out of operation.....	59
8.4	Shutting the unit down.....	60
8.5	Putting the unit into operation after a shutdown.....	61
8.6	Changing the unit over to another working fluid.....	61
9	Troubleshooting.....	62
9.1	Safety.....	62
9.2	Service.....	62
9.3	Troubleshooting table.....	62
10	Maintenance.....	63
10.1	Safety.....	63
10.1.1	Before starting all maintenance.....	63
10.1.2	With all maintenance work.....	63
10.1.3	After all maintenance work.....	65
10.2	Inspection and maintenance plan.....	65
10.2.1	Fans.....	66
10.2.2	Unit heat exchanger.....	66
10.3	Maintenance work.....	68
10.3.1	Remove leaks.....	68
10.4	Clean unit.....	68
10.4.1	General.....	68
10.4.2	Removing the drip tray and side cover.....	69
10.4.3	Clean and defrost heat exchanger.....	70
10.4.4	Cleaning fans.....	71
10.5	Defrosting the unit.....	73
10.5.1	Notes on defrosting.....	73
10.5.2	Defrost control.....	74
10.5.3	Circulation air defrosting.....	75
10.5.4	Electric defrosting (optional)(accessory at customer's request).....	76
10.5.5	Hot gas defrosting (option).....	76
10.5.6	Further notes on defrosting.....	77
11	Plans/diagrams.....	79
11.1	Electrics documentation.....	79
11.1.1	Fan motor connection diagram.....	79
11.1.2	Connection diagram electrical defrost (selectable option; accessory on customer request).....	79

1 Important basic information

1.1 Safety instructions

1.1.1 Observing operating instructions

CAUTION

- ▶ Always keep the operating instructions in the unit's immediate vicinity at all times.
- ▶ Ensure that the operating instructions are accessible to all people that have anything at all to do with the unit at all times.
- ▶ Ensure that the operating instructions are read and understood by all people that have anything at all to do with the unit.

1.2 Importance of the EN 378 series of standards – refrigeration systems and heat pumps – safety-related and environmental requirements

EN 378 deals with safety-related and environmental requirements for designing, constructing, producing, installing, operating, maintaining and disposing of refrigeration systems and cooling equipment.

EN 378 is oriented towards manufacturers, installers and operators of refrigeration systems and cooling equipment (see section 1.2. Responsibilities).

The objective of EN 378 is to restrict the possible hazards of refrigeration systems, cooling equipment and their working fluids (refrigerants and coolants) for people, property and the environment to a minimum.

Insufficient safety measures or non-compliance with safety-relevant regulations can result in:

- Breaks or ruptures on components with the danger of escaping materials (hazards caused by the influence of low temperatures, excess pressure, direct influence of the fluid phase, moving machine parts).
- Escaping working fluid after a break or leak because of defective design, improper operation, insufficient maintenance, repairs, filling and disposal (hazards caused by damage to health, frost-bite, suffocation, panic).

1.3 Responsibilities

1.3.1 Manufacturer's responsibilities

The notes provided in these operating instructions on maintaining the unit's functional safety, preventing possible hazards when transporting, setting up and installing, start-up and operation, and with maintenance activities (cleaning, servicing and repairing) refer exclusively to the unit.

The manufacturer's responsibilities are documented in the unit's version in acc. with EN 378-2 (design, manufacture and testing).

The materials used in the construction and for soldering are designed to withstand the foreseeable mechanical, thermal and chemical stresses, and are resistant to the working fluids used and to mixtures of such working fluids and the oils used to lubricate refrigeration compressors.

The working fluid-carrying parts of the unit (core tubes, distributor tube and header outlet) are configured so that they remain tight with the foreseeable mechanical, thermal and chemical stresses, and withstand the maximum permissible operating pressure.

Material, wall thickness, tensile strength, corrosive resistance, shaping process and testing are suitable for the working fluid used and withstand the possible pressures and stresses that might occur.

All responsibility for the equipment into which the unit is integrated, are the exclusive responsibility of the people involved in the individual workflows.

1.3.2 Responsibilities of the system's installer

The responsibilities of the system installer are documented in the system's version (design, manufacture and testing – in accordance with EN 378-2).

Component supplier-system installer interfaces :

- In the event of any malfunction, inform Guntner GmbH & Co. KG :
Inform Guntner GmbH & Co. KG immediately if faults occur during the set-up, installation, start-up and operation..

The responsibilities of the system installer in particular include:

- Planning and preparing emergency measures:
To avoid consequential damage caused by operational disruptions, a warning system which immediately signals all faults must be provided on-site. Prepare emergency measures that prevent consequential damage for people and property should faults occur.
- Specify checking and maintenance intervals:
The system must be configured and equipped with all required equipment for maintenance and sufficient servicing and testing in accordance with EN 378-4.

When the unit is integrated into the refrigeration system , the working fluid and version must not deviate from the order-related information specified in the order-related documents.

The installer of the system must refer to the requirement for sufficient instruction of the operating and supervision staff when operating and maintaining the equipment .

It is recommended that the future customer staff – if possible – be present during the set-up and installation, for tightness tests and cleaning, while the system is being filled with working fluid and for the adjustment of the equipment .

1.3.3 Owner or operator responsibilities

The owner or operator responsibilities are documented in the operation, maintenance, servicing and recovery of the system in accordance with EN 378-4.

The owner or operator must ensure that the proper people are sufficiently trained and qualified for operating, monitoring and servicing the system .

The operating personnel for the system must have sufficient knowledge and experience with regard to the mode of operation, operation and daily monitoring of this system .

Before starting up the system, the owner or operator must ensure that the operating personnel are sufficiently instructed about the system's documentation (which is part of the operating instructions) on the set-up, monitoring, mode of operation and servicing of the system and the safety measures to be observed, and with regard to the properties and handling of the working fluid to be used.

The owner or operator must ensure that when operating, monitoring and maintaining the system the working fluid and version must not deviate from the details specified in the order-related documents.

Planning and preparing emergency measures: To avoid consequential damage caused by operational disruptions, a warning system must be installed on the customer's premises. Prepare emergency measures that prevent consequential damage for people and property should faults occur.

Responsibility remains with the owner or operator of the system, if the system are used by anybody else, unless there is a contrary agreement on sharing responsibility.

1.4 Legal notes

Warranty claim expires as follows:

- With faults and damages that can be attributed to non-compliance with the specifications of these operating instructions.
- With complaints that can be attributed to use of spare parts other than the original spare parts specified in the order-related offer documents.
- With changes to the unit (working fluid, version, function, operating parameters) vis-a-vis the order-related information specified in the order-related offer documents without the manufacturer's prior consent.

The operating instructions may not be reproduced electronically or mechanically, circulated, changed passed on to third parties, translated or used otherwise, in full or in part, without Guntner GmbH & Co. KG's prior explicit written approval.

1.5 Operating instructions

1.5.1 Scope

These operating instructions apply to all CO₂evaporators of the CPGHN.2 series.

NOTICE

You will find the precise type of your unit in the attached order-related documents.

1.5.2 Set-up and other applicable documents

The unit's operating instructions include the following parts:

- These instructions
- Order-related documents
 - The order-related documents are included with these instructions and contain the following information:
 - The order-related proper use as specified
 - The order-related scope of delivery
 - The order-related technical data
 - The order-related drawings specifying customer, project number and order number
- Motor connection wiring diagram in terminal boxes

These operating instructions are part of the operating instructions manual of the system, provided by the system's installer.

1.6 Conventions

1.6.1 Typographical conventions

The following text markups are used in these operating instructions:

Bold	Requires special attention!
Grey triangle	Instructions

1.6.2 List of abbreviations

Abbreviations	Meaning
CO ₂	CO ₂ refrigerant (R744)
EN 378	European Norm 378: Refrigeration systems and heat pumps; safety-related and environmental requirements
EN	European Norm
DIN	German industrial standard (specification of a standard)
ISO	International Standardization Organization .
°C	Degrees Celsius (Celsius scale temperature)
is	Unit of pressure
l	Litre (liquid volume)
Vol%	Volume percent (concentration level relative to a volume)
IP	Insulation protection
Q 6,3	Balancing quality
ppm	parts per million, concentration figure, stands for "millionth part".
Hz	Hertz (frequency)
D	Delta connection (alternating current: high speed)
S	Star connection (alternating current: low speed)
3~	3-phase current
1~	1-phase alternating current
VDE	"Verband der Elektrotechnik, Elektronik und Informationstechnik" (Association for Electrical, Electronic & Information Technologies)
TCC	Technical Connection Conditions
EPC	Electric Power Company
VDI	"Verein Deutscher Ingenieure" (German engineers' association)

1.7 Conventions for safety signs and notices

1.7.1 General safety signs and their meaning in these operating instructions

DANGER

Dangerous situation that will definitely cause serious injury or death if it is not avoided.

WARNING

Dangerous situation that could cause serious injury or death if it is not avoided.

CAUTION

Dangerous situation that could cause slight to moderate injury if it is not avoided.

NOTICE

Refers you to possible damage to property.

1.7.2 Warning symbols and their meaning in these operating instructions



Warns against hand injuries!

Failure to comply with warnings may result in hands or fingers being crushed, dragged in or otherwise injured.



Warns against hot surfaces!

The temperature is over +45°C (at which protein clots) and can cause burns.



Warns against cold!

The temperature is below 0°C and can cause frostbite.



Warns against dangerous electrical voltage!

Danger of an electric shock if voltage-carrying parts are touched.



Warns against harmful to health or irritant substances at set-up point

Contact with or inhaling substances that are irritant or harmful to health can cause injuries or damage peoples' health.



Warning of automatic start-up

If the unit starts up automatically during maintenance work there is a danger of pinching/trapping the hands and fingers.



Warning against high operating pressure!

Caution! CO₂ evaporators of the CPGHN.2 series work with a very high operating pressure. Danger from high operating pressure: 50 bar

Breaks in pressurised pipes or pressurised components of the unit can cause injuries or damage to property due to flying debris.

1.7.3 Prohibitory signs and their meaning in these operating instructions



Fire, open fire and smoking prohibited!

Ignition sources must be kept away and ignition sources must not develop!



No smoking!

Smoking is forbidden.

1.7.4 Mandatory signs and their meaning in these operating instructions.



Use eye protection!

Eye protection: Use protective cover, protective glasses or face protection.



Use hand protection!

Protective gloves must protect against mechanical and chemical dangers (see imprinted pictograms).



Use respiratory protection!

Breathing apparatus must be suitable for the working fluid used. Breathing apparatus must consist of:

- At least two independent breathing devices (self-contained breathing apparatus)



Use protective clothing!

Personal protective clothing must be suitable for the working fluid used and for low temperatures, and must have good heat insulation properties.



Activate before work!

Activate the electrical system and secure against switching on again before starting installation, maintenance and repair work.

2 Safety

2.1 Labelling on the unit:

Placing identifiers on the unit

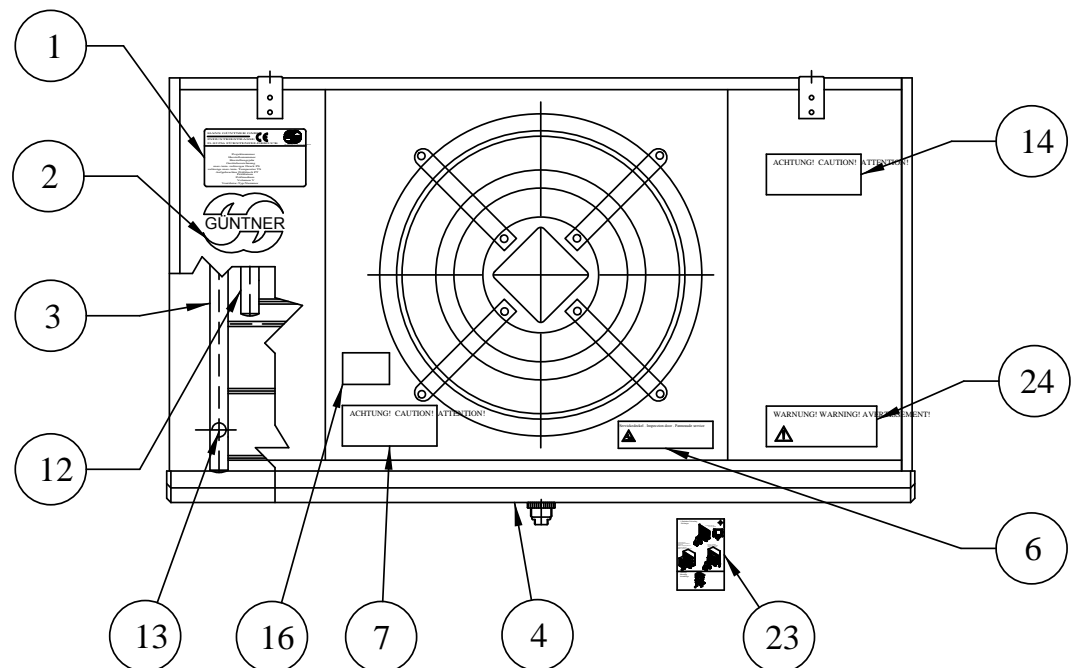

Placing identifiers on the unit

2.1.1 Safety signs on the unit

Safety signs on the unit individually:

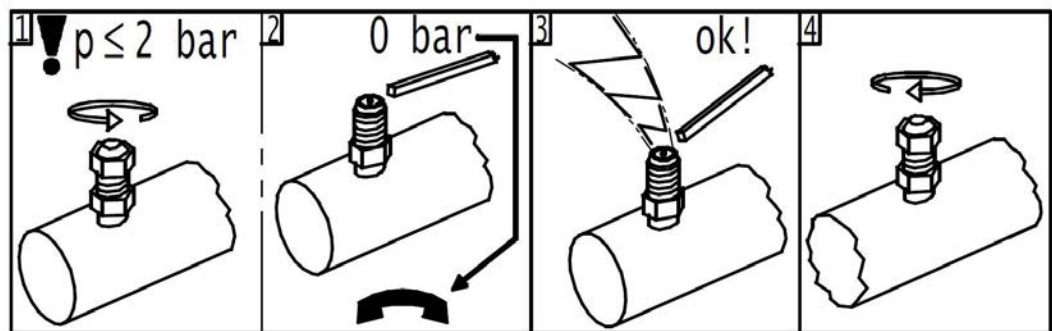

940 - "Transportation filling" warning sign next to Schrader valve

Achtung • Caution • Attention

Ventilator-Betrieb nur mit Schutzgitter!

Gefahr!

Fan operation only with guard grille!

DANGER!

Mode opératoire de ventilateur qu'avec grille protectrice!

DANGER!

Art.Code:3083

3083 - "Protection grill" warning sign (only used with separate removable protection grill)

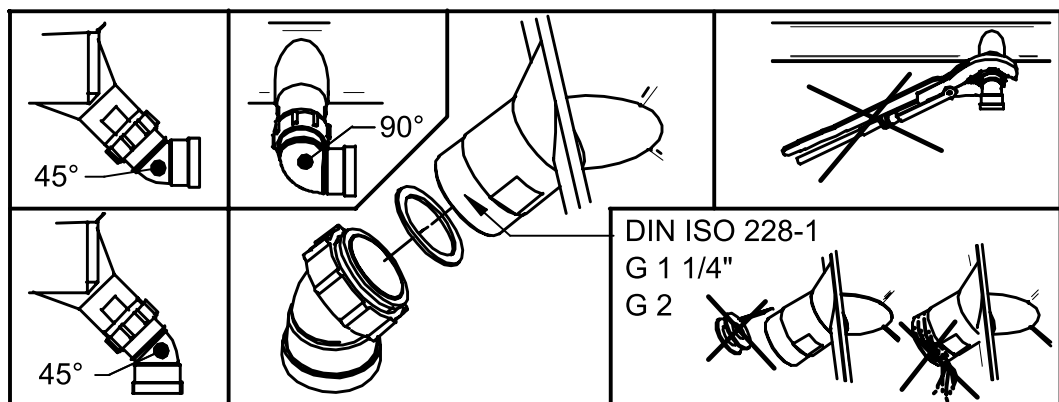

5965 - Tray drain warning sign

**Schwenkbarer Ventilator • swivelling fan
ventilateur à pivot • ventilador girable**

Achtung: Vor dem Öffnen der Ventilatorverschraubung Gerät immer **spannungsfrei schalten**, da sonst Gefahr durch automatischen Anlauf des Ventilator besteht!

Warning: Before unscrewing the fan screw joints, the unit must always be **switched to zero potential**, because otherwise there is danger of automatic start-up of the fan!

Attention: Avant de dévisser les vis du ventilateur, il est indispensable de **mettre le ventilateur sans tension**, autrement, il y a le danger d'un démarrage automatique du ventilateur!

Atención: Antes de destornillar los tornillos del ventilador, es indispensable el aparato esté **sin tensión**, de lo contrario, hay peligro de un arranque automático del ventilador!

Art.-Code 5969

5969 - "Swivel fan" (optional) warning sign



Während der Wartungsarbeiten ist der Aufenthalt im Gefahrenbereich unter dem Gerät **VERBOTEN!** Kondensatwanne kann sich bei unsachgemäßer Handhabung vom Gerät lösen und herabstürzen. Beim Öffnen der Wanne muss mit erhöhtem Wannengewicht infolge von Eis und Wasser gerechnet werden!

Do not stay in the hazardous zone below the unit during maintenance work!
The drip tray can loosen and fall down in case of improper handling.
When opening the drip tray, be aware that the drip tray's weight can be increased due to ice or water!

Art.-Code 61100

61100 - Tray safety catch warning sign

2.1.2 Other signs and notes on the unit

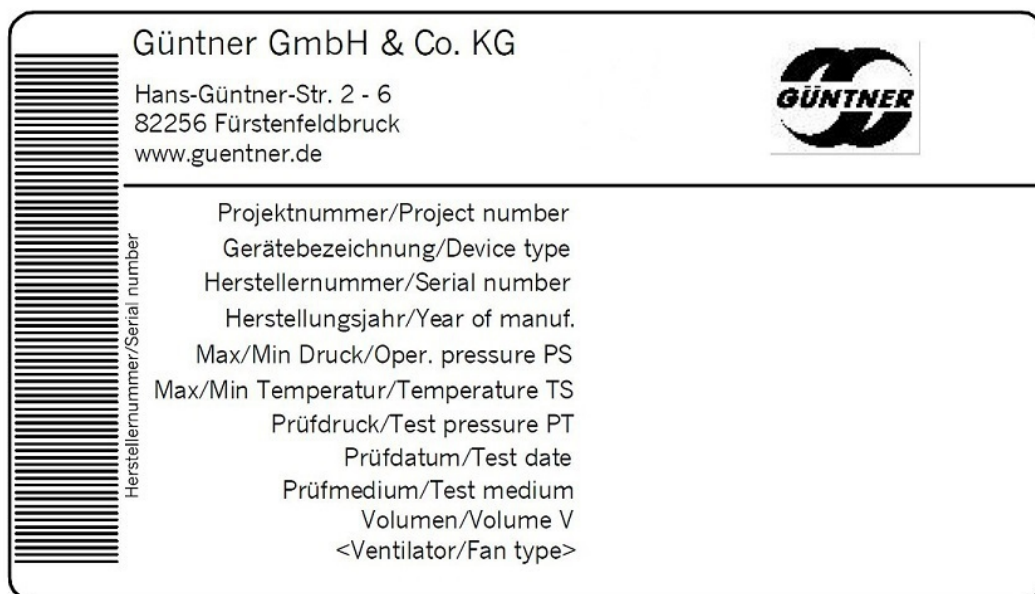

2483 - Example of a manufacturer's nameplate



2119 – Logo

- Hinweis:** Güntner streamer haben Gleichrichterfunktion. Kein zusätzlicher Gleichrichter erforderlich.
- Note:** The Güntner streamer has an air rectifying function. No additional air rectifier needed.
- Remarque:** La fonction du Güntner-streamer est le redressement du jet de l'air. Une grille supplémentaire n'est pas nécessaire.
- Nota:** Güntner-streamer tienen función de direccionar el aire, or lo tanto no se requiere rejilla adicional.

9 – Note for Streamers (only when a Güntner Streamer is used)

Eintritt/Entry/Entrada/Entrée 

Austritt/Exit/Salida/Sortie 

943 and 943.1 - Connections IN and OUT

ACHTUNG – ATTENTION – ATTENTION – ATENCIÓN

Bei der Verwendung von Reinigungsmitteln in Kühlräumen, ist auf die Korrosionsbeständigkeit der Materialien des Kühlers gegenüber dem verwendeten Reinigungsmittel zu achten!

When cleaning agents are used inside the cold room, the corrosion resistance of the cooler materials to the applied cleaning agent has to be observed!

Lors de l'utilisation des détergents dans les chambres froides, il faut observer la résistance à la corrosion des matériaux de l'appareil qui entrent en contact direct avec les détergents.

Cuando se apliquen agentes limpiadores en los productos instalados en cámaras frías, se debe tener cuidado que no corraen los materiales usados para la construcción del producto!

947 - Corrosion resistance

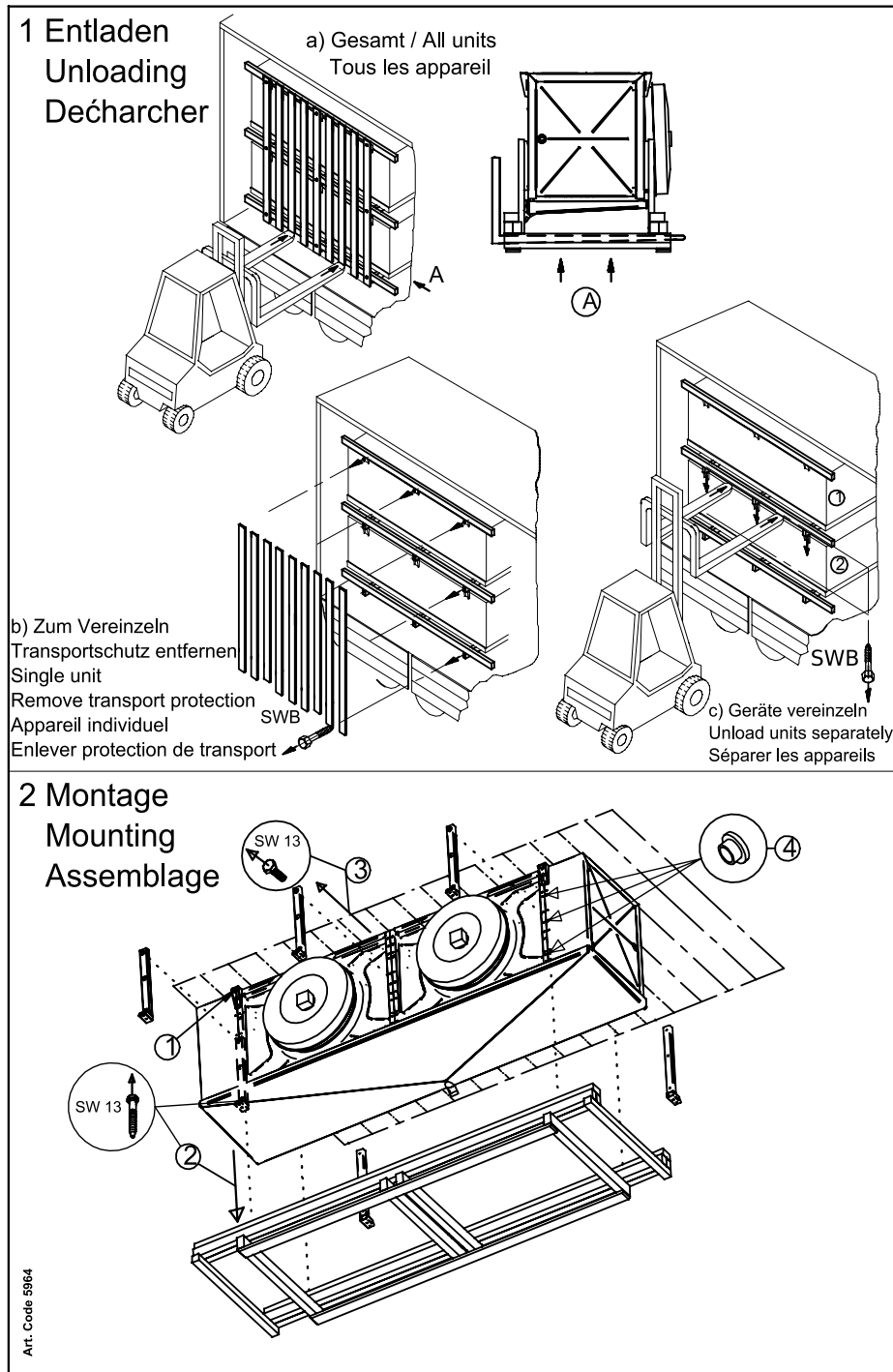

2 Montage
Mounting
Assemblage

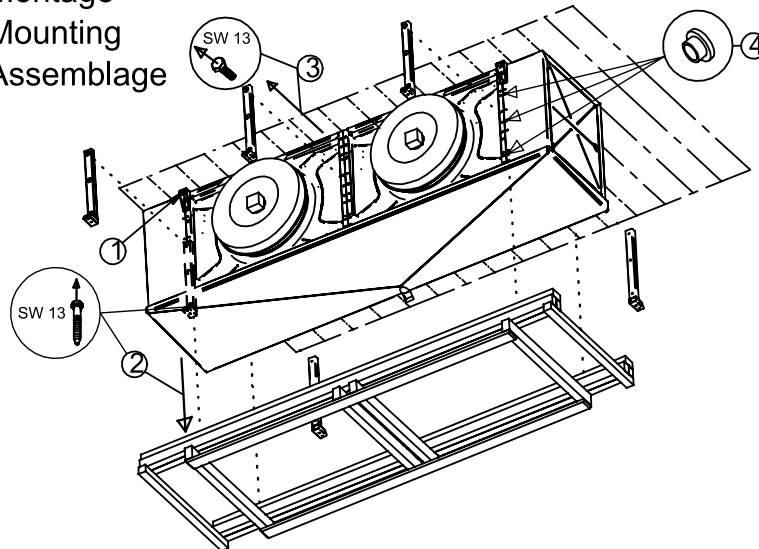

20 - Trailer loading – Ceiling-mounted air cooler

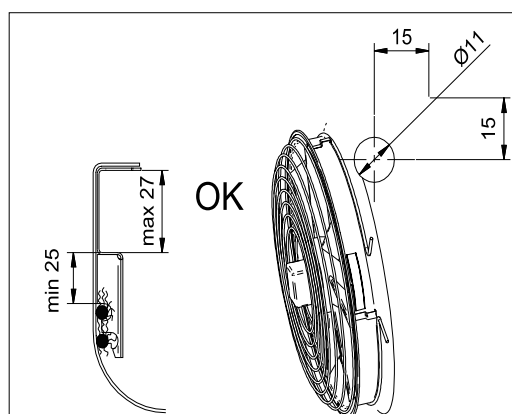

2.2 Basic safety notices

2.2.1 How to act in an emergency

WARNING



Danger of injuries and damage to property!

CO₂ is an irritant gas and when inhaled causes agitation, dizziness, vomiting and cramps; with heavy concentrations suffocation and life-threatening pulmonary oedema.



Irritation of the respiratory centre with 30,000 to 50,000 ppm (3 to 5 vol %).

Unconsciousness with 70,000 to 100,000 ppm (7 to 10 vol%).

Safety measures and procedure:

- In the event of serious unexpected leakage of refrigerant, leave the set-up room immediately and activate the emergency measures provided, e.g. if:
 - Visibly escaping refrigerant liquid or vapour from the heat exchanger or tube components.
 - Sudden large release (release and evaporation of the greater part of the entire refrigerant filling in a short time, e.g. in less than 5 minutes).
 - Sudden irritation of the respiratory centre
 - Activation of the NH₂ alarm device (NH₃ concentration > 5,000 ppm - MAC value):
- Have experienced, trained personnel with appropriate protective clothing perform all necessary protective and other measures:
 - Use respiratory protection.
 - Use a room air-independent breathing apparatus for maintenance work in high CO₂ concentrations in the room air.
 - Ensure the set-up room is well ventilated.
 - Divert escaped refrigerant vapour and escaped refrigerant liquid safely.



Caution!

CO₂ evaporator gas coolers/condensers of the CPGHN.2 series work with a very high operating pressure. Danger from high operating pressure: 50 bar!

Breaks in pressurised tubes or pressurised components of the unit can cause injuries or damage to property caused by flying debris ([see Residual hazards caused by pressurised parts, page 27](#)).

2.2.2 Personnel, care requirements

CAUTION

The unit may be installed, put into operation, operated, maintained and repaired only by trained, experienced and qualified personnel. In order to be considered qualified, people who are to be responsible for the operation, maintenance, repair and evaluation of systems and their components must have the necessary training and specialist knowledge for such work, as stipulated in EN 378-1. Qualified or expert means the ability to satisfactorily perform the activities required for the operation, maintenance, repair and evaluation of refrigeration systems and their components.

The unit may be operated by operating personnel that have no specific knowledge of refrigeration engineering, but have sufficient knowledge and experience with regard to the mode of operation, operation and daily monitoring of this system. This operating personnel may not make any interventions or settings on the system.

Changes to the unit, which the manufacturer has first agreed to in writing, may only be made by the instructed and qualified personnel.

Electrical installation:

Work on the electrical equipment may only be performed by personnel that have the required expertise (e.g. an electrician or an electro-technically instructed person), and who are authorised by the operator, in compliance with the respective VDE regulations (and national and international provisions) and the TCCs of the EPCs.

2.3 Proper intended use

2.3.1 Proper intended use

CO₂ evaporators of the CPGHN.2 series are intended for installation in a refrigeration system and are used for cooling and circulating the room air in cold storage rooms, deep-freeze rooms, etc. (especially in the temperature range between -40 and -50°C),.

The unit is delivered for operation with a specific operating point:

- Evaporation temperature
- Airflow volume
- Air inlet temperature
- Relative air humidity.

The specified operating point is given in the order-related documents.

2.3.2 Operating conditions

The unit is a component a cooling system including its working fluid circuit. The purpose of these operating instructions, as part of the operating instructions manual (of which these operating instructions are a part), is to minimise the danger to people and property and the environment from the unit and the working fluid used in it. These dangers are essentially connected with the physical and chemical properties of the working fluid and with the pressures and temperatures that occur in the working fluid-carrying components of the unit [see Residual hazards due to carbon dioxide \(CO₂\), page 25](#).

WARNING

Danger of injuries and damage to property!

CO₂ evaporators, of the CPGHN.2 series work with a very high operating pressure. Danger from high operating pressure: 50 bar!

Breaks in pressurised tubes or pressurised components of the unit can cause injuries or damage to property caused by flying debris ([see Residual hazards caused by pressurised parts, page 27](#)).

 **WARNING**

Danger of injuries and damage to property!

The unit may be used only in accordance with the proper intended use. The operator must ensure that when operating, monitoring and maintaining the unit, the fluid used and the mode of operation do not deviate from the order-related information specified in the order-specific documents.

The operator must ensure that maintenance measures are performed in compliance with the system's operating instructions manual.

Filling the unit with a different fluid is permitted only following written approval by the manufacturer. You will find the order-related proper use as intended in the order-specific documents.

Do not exceed the max. operating pressure given on the unit's type plate.

2.3.3 Improper use

 **WARNING**

Danger of injuries and damage to property!

Working fluids and their combinations with water or other substances in the working fluid-carrying components have chemical and physical effects from the inside on the materials surrounding them. The unit may be pressurised only with CO₂. Pressurising the unit with another working fluid would have the effect that

- the structural and welding materials used would be unable to withstand the foreseeable mechanical, thermal and chemical stresses and the pressures that may occur during operation and when shut down,
- material, wall thickness, tensile strength, corrosive resistance, shaping process and testing are not suitable for the working fluid used and do not withstand the possible pressures and stresses that might occur.
- the unit would not be resistant to the other working fluid and the combination of the other working fluid and
- the unit not remaining tight during operation and when shut down.
- a possible sudden escape of working fluids could directly endanger people and/or property and the environment.

The maximum permissible operating temperature specified on the type plate must not be exceeded! If the operating temperature is exceeded,

- the unit would be exposed to an impermissibly high pressure (pressure/temperature correlation),
- signs of material fatigue would emerge,

The maximum permissible operating pressure specified on the type plate must not be exceeded! If the operating pressure is exceeded,

- the parts of the unit carrying the working fluid might not withstand the foreseeable mechanical, thermal and chemical stresses and the pressures that may occur during operation and when shut down,
- the unit would not remain tight during operation and when shut down,
- there may be a possible sudden escaping of working fluids after a break or leakage on working fluid-carrying components, which would result in the following dangers:
 - Danger of escaping materials
 - Hazard of irritation of respiratory centre,

- danger of frostbite (caused by liquid coolant squirting/splashing),
- Suffocation hazard
- hazards caused by panic reactions, agitation, dizziness, vomiting and cramps,
- Environmental pollution

 **WARNING**

Warning!

the CO₂ evaporators, in this CPGHN.2 series use a very high operating pressure. Danger from high operating pressure: 50 bar!

Breaks in pressurised tubes or pressurised components of the unit can cause injuries or damage to property caused by flying debris ([see Residual hazards caused by pressurised parts, page 27](#)).

 **WARNING**

CO₂evaporators may not be used

- where it is possible that short or prolonged effect caused by contact, inhalation or ingestion of the working fluid CO₂ might result in harmful or fatal hazards.
- where the possibility exists of a sudden large release (release and evaporation) of the greater part of the entire working fluid filling in a short time (e.g. in less than 5 minutes).
- where the possibility exists that the longest time that people are exposed to a large release of the CO₂ refrigerant is more than 60 minutes when the refrigerant concentration exceeds 5,000 ppm (MAC value) and the number of clearly identified emergency exits for the number of usually present people are not available.
- where the number of clearly identified emergency exits for the number of usually present people are not available.

The unit must not be changed without the prior written consent of GÜntner GmbH & Co. KG . Changes to the unit are:

- Changing the operating point (as specified in section [see Unit, page 32](#))
- Changing the fan capacity (air volume)
- Changing the working fluid flow-through volume
- Changing over to another working fluid

The unit must not be operated if safety devices recommended by the manufacturer are not available, not properly installed or not fully functional.

The unit must not be operated if it is damaged or demonstrates faults. All damage and faults must be reported to GÜntner GmbH & Co. KG immediately and dealt with promptly.

Work on the unit must not be performed without the personal protective equipment specified in these operating instructions.

2.4 Mechanical residual hazards

2.4.1 Fins, sharp unit corners and edges

⚠ WARNING



Warns against hand injuries!

Danger of cuts on hands and fingers on the fins and on sharp corners and edges of the unit.



Use reliable hand protection!

2.4.2 Flap down drip tray

⚠ WARNING

Warning against personal injury and damage to property!

Danger of falling unit parts, masses of water or ice when the drip tray is flapped out.

Nobody is allowed to be in the danger area below the unit during cleaning or maintenance work.

The drip tray can be flapped down for cleaning and is protected from falling down by a safety catch. Unit parts, masses of water or ice can nonetheless fall down when it is flapped down.

2.4.3 Fans

⚠ WARNING



Danger of cutting off, pulling in!

There is a danger of cutting off fingers on the rotating fan blades, injury hazard for the hands and pulling in danger for loose elements such as hair, necklaces or clothing parts.

Do not operate fans without guard grille. Pinch/trap point hazard!



With automatic fan start during maintenance work there is a danger of pinching/trapping for the hands and fingers.

Power off the unit before you begin maintenance work with which you must remove the guard grille. Secure the unit against unintentional switching on again by removing the electric fuses for the unit. Secure the unit with a suitable warning sign referring to unintentional switching on.



The swivel fans (option for sizes 071 and 081) must only be opened by trained specialist staff with suitable tools and only for maintenance and repair purposes. Close the swivel fans after completing the work and secure them against unintentional or unau-

thorised opening! Only open the lock screw connection after turning off the fan's power (power-off state)!

**Schwenkbarer Ventilator • swivelling fan
ventilateur à pivot • ventilador girable**

Achtung: Vor dem Öffnen der Ventilationsverschraubung Gerät immer **spannungsfrei** schalten, da sonst Gefahr durch automatischen Anlauf des Ventilators besteht!

Warning: Before unscrewing the fan screw joints, the unit must always be switched to **zero potential**, because otherwise there is danger of automatic start-up of the fan!

Attention: Avant de dévisser les vis du ventilateur, il est indispensable de mettre le ventilateur **sans tention**, autrement, il y le danger d'un démarrage automatique du ventilateur!

Atención: Antes de destornillar los tornillos del ventilador, es indispensable el aparato esté sin **tension**, de lo contrario, hay peligro de un arranque automático del ventilador!

Warning notice for swivel fan (option for sizes 071 and 081) on the unit

2.4.4 Hinged side plates

WARNING



The removable side plates may be opened only by trained specialist staff using a suitable tool (sizes 040.2, 045.2, 050.2 with screw drivers) and only for maintenance and repair purposes. The first time it is opened the screws will need to be loosened. Close the removable side plates after completing the work and secure them against unintentional or unauthorised opening!



Caution!

The snap lock must not be secured at the manufacturer side. The operator must ensure the securing.



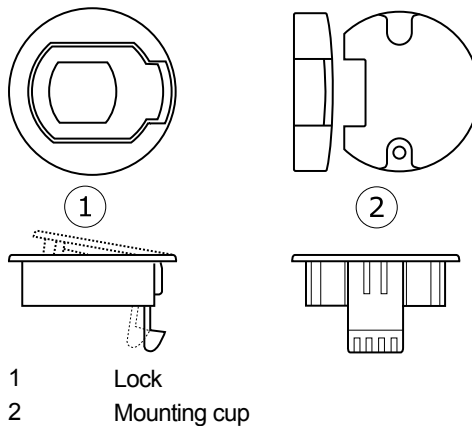
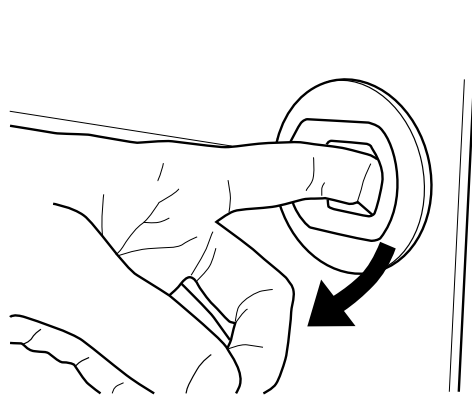

2.5 Electrical residual hazards

⚠ WARNING



Warns against dangerous electrical voltage!

Direct and indirect contact with voltage-carrying parts of motors and electrical lines can cause serious injuries or death.



Power off the unit before you begin maintenance work. See the refrigeration system's system documentation for this. Secure the unit against unintentional switching on again by removing the electric fuses for the unit. Secure the unit with a suitable warning sign referring to unintentional switching on.

Please note that the mains cables may also be carrying voltage, even if the unit is powered off.

Work on electrical equipment may be performed only by people that have the required expertise (e.g. an electrician or an electro-technically instructed person) and who are authorised to do so by the operator.

2.6 Thermal residual hazards

2.6.1 Frostbite hazard

WARNING



Warns against cold!

In refrigeration operation the heat exchanger and pipes have a temperature below ± 0 °C. Contact can cause frostbite.

Use hand protection!



2.7 Residual hazards due to carbon dioxide (CO₂)

The unit is operated with carbon dioxide (CO₂). Carbon dioxide is a group L1/A1 refrigerant in accordance with classification according to flammability (L) and toxicity (A) in compliance with EU Directive 97/23/EG on pressure equipment (Pressure Equipment Directive):

- Refrigerants that, when gaseous, are non-flammable irrelevant of their concentration in air.
- Refrigerants with a time-weighted, averaged concentration that have no adverse effects on the majority of staff that are exposed every day during a normal 8 hour working day and a 40 hour working week to this concentration, which is greater than or equal to 400 ml/m³ (400 ppm (V/V)).

Carbon dioxide (CO₂) as a refrigerant has the following properties:

- Non-flammable, known fire extinguisher agent
- Non-toxic, food safety-approved and declaration-free
- Odourless
- Colourless
- Taste-neutral
- Heavier than air
- Stable compound, used under normal ambient conditions as an inert gas
- Combination with water $\text{CO}_2 + \text{H}_2\text{O} = \text{H}_2\text{CO}_3$. Of dissolved CO₂ gas in water, only 0.1% is present as acid. The pH value of watery CO₂ solutions at normal pressure is 3.7. Under pressure it falls to a limit value of 3.3. CO₂ is therefore suitable as a neutralisation medium for basic solutions.
- Medical applications: Inhalations of 3 to 5% CO₂ in breathing gas.

There is no imminent danger for the staff. With good air ventilation and removal by suction, it will fall easily and clearly below the allowed limit values.

WARNING

Danger of harm to health and environmental damage!

Refrigerants of the Group L1/A1 are generally heavier than air and may flow off to rooms on a lower level. In still air there may be an increase of the ground level concentration. With high concentrations there are the following hazards – especially near to the floor:

- Irritation of the respiratory centre with 30,000 to 50,000 ppm (3 to 5 vol %).
- Unconsciousness with 70,000 to 100,000 ppm (7 to 10 vol %) due to lack of oxygen.
- CO₂ is an irritant gas and causes agitation, dizziness, vomiting and cramps, with high concentrations causing suffocation and life-threatening pulmonary oedema.

Always observe the following safety instructions:

- Unauthorised people must not have access to the unit.
- Ensure working rooms are well-ventilated in order to prevent inhalation of high vapour concentrations. MAC value 5,000 ml/m³ (ppm) as 8 h average value; a concentration of 10,000 ppm (instantaneous value) for 60 min. three times per shift is permitted a peak limit.
- Ensure that the CFC/HFC refrigerant escaping from the unit cannot penetrate the interior of the building or put people at risk in any other way. CO₂ refrigerant vapour or gas must be kept from penetrating neighbouring rooms, staircases, yards, passages or drainage systems and must be discharged without risk.
- Monitor the CO₂ refrigerant concentration in the ambient air to ensure constant compliance with limit values. With good air ventilation and removal by suction, it will fall easily and clearly below the allowed limit values.
- With emergency work in high CO₂ refrigerant concentrations in the room air wear a room air-independent breathing apparatus.
- Prevent the refrigerant or oil from escaping: Test the tightness of the unit regularly, as specified in these operating instructions ([see Inspection and maintenance plan, page 65](#)).
- With leaks on the evaporator (escaping CO₂), if hazard-free handling is guaranteed, the emergency STOP switch must be pressed and the endangered unit shut off.
- Harmful to the environment effects: CO₂ must not be released into the atmosphere – environmental damage (with a 50% content CO₂ is one of the most significant anthropogenic greenhouse gases)



Ignition and fire hazard!

- With work involving fire or sparks, e.g. grinding, welding, etc., ensure suitable fire fighting equipment is on-site.
- In particular be aware of the danger of ignition of oil residues unintentionally carried in in the CO₂ refrigerant.



- Ensure that the provided fire fighting equipment is provided in sufficient quantities, that it functions properly and that the extinguishing agent does not react with the CO₂ refrigerant.
- Smoke during work is forbidden!



Frostbite hazard

Frostbite if CO₂ comes into contact with the skin or eyes (-57°C). Leaks in the unit can cause the CO₂ refrigerant to escape into the set-up room.

- When removing faults after spills of CO₂ refrigerant, you must be vigilant for any remaining superheated CO₂ refrigerant as splashes can cause frostbite and evaporation can cause irritation.



Danger of poisoning!

CO₂ refrigerant contact with fire can form toxic combustion products.

- Prevent CO₂ refrigerant contact with open fire.
- Welding and soldering may therefore take place only after completely draining the relevant section of the system of the CO₂ refrigerant. Ensure good ventilation here!
- With emergency work in high CO₂ refrigerant concentrations in the room air wear a room air-independent breathing apparatus.



2.8 Residual hazards caused by vibrations

WARNING

Danger of injuries and damage to property caused by escaping materials

If fans are damaged during fan operation, flying parts of the fan blades can injure people or cause damage to property close to the fan.

Fans, components and cables in system, must be designed, constructed and integrated so that dangers caused by vibrations that it or other parts of the system generate, are reduced to an absolute minimum, while incorporating all available means for reducing vibrations, preferably at the source.

NOTICE

Damage to property caused by vibrations

Vibrations that are increased by imbalances, as created by dirt, icing or fan blade damage, are regularly caused with fan operation. The vibrations are transferred to the unit, where they can cause damage and damage the unit mounting or components connected to the unit.

Check fan blades and protection grill regularly for contamination and frost and/or ice and make sure the fans run smoothly ([see Fans, page 66](#)).

2.9 Residual hazards caused by pressurised parts

WARNING

Injury and damage to property caused by pressurised parts that contain CO₂ refrigerant!

Breaks in pressurised pipes or pressurised components of the unit can cause injuries or damage to property caused by escaping materials (A sudden large release of the working fluid with its hazardous properties after a break or leak on pressurised components of the unit can cause the following hazards:

- Irritation of the respiratory centre
- Frostbite (caused by liquid refrigerant squirting/splashing)
- Suffocation

- Panic, agitation, dizziness, vomiting and cramps
- Environmental pollution

Ensure that the unit in question is pressure-free before maintenance work begins or remove the working fluid from the unit in question.

⚠ WARNING

Please note!

CO₂ evaporators, of the CPGHN.2 series work with a very high operating pressure. Danger from high operating pressure: 50 bar!

Breaks in pressurised pipes or pressurised components of the unit can cause injuries or damage to property caused by escaping materials.

2.10 Residual hazards caused by defective installation

⚠ WARNING

Caution!

CO₂ evaporators, of the CPGHN.2 series work with a very high operating pressure. Danger from high operating pressure: 50 bar!

Breaks in pressurised tubes or pressurised components of the unit can cause injuries or damage to property caused by flying debris ([see Residual hazards caused by pressurised parts, page 27](#)).

⚠ WARNING

Injuries and damage to property caused by defective installation!

Defective installation results in hazards caused by:

- Break or leak on liquid-carrying unit components and pipes
- Absence of release devices to prevent liquid escape: Observe the magnet valve/check valve sequence combination in the fluid line: In the flow direction the magnet valve must be installed first and then the check valve. If the sequence is reversed, liquid will be locked in between the check valve and the magnet valve when the magnet valve is closed; this will heat up during shutdown state and can cause pipes or connection flanges to break when it expands. This applies in particular to lines carrying cold liquids.
- Uneven load distribution on the fixtures with the danger of stresses within the unit or unit displacement (breaks or leaks on fluid-carrying components of the unit and pipes; danger of breaking off).
- Insufficient securing of working fluid-carrying lines against mechanical damage! On-site connections: loaded installation; effect of forces on the distribution and header pipes with the danger of breaks or leaks on fluid-carrying components of the unit and pipes; danger of breaking off!
- Break-off and fall danger of the unit with hazard of escaping working fluid and exposed electrical cables.
- Danger of damage caused by environment-conditional hazard sources (production, transport and other processes at the set-up point).
- Unit functional faults caused by air inlet/outlet obstructions.
- Obstructed heater rods exchange with electric defrosting (accessory at customer's request)/
- Obstruction of all-side inspection, checks and maintenance, i.e. no unobstructed accessibility to the working fluid-carrying and electrical components, connections and cables, no recognisable identifiers on the pipes and insufficient space for tests.

Ensure that:

- The units are to be installed on the fixing points corresponding with their weights and tightened with fixing bolts. The operator or installer is responsible for ensuring that the bolted connections are of an adequate strength.
- The diameters of the mounting holes have been statically determined by the manufacturer and the fixing bolts are adapted accordingly.
- The fixing bolts are secured against loosening by means of an appropriate locking device.
- The fixing bolts are not overtightened or stripped.
- All fixing bolts are tightened equally to achieve a load distribution on the connections that is as balanced as possible.
- All fixing points maintain the same spacing to the fixing level permanently and under load, so that no mechanical stress occurs in the unit structure. The units are anchored in their fixing position in order to prevent the equipment from moving.
- The functional safety of the fixing bolts is tested as part of the maintenance periods. [see Maintenance, page 63](#).
- The unit is fixed and set up so that it is not damaged by environment-conditional hazard sources (production, transport and other processes at the set-up point) or its functioning is not disturbed by the interventions of unauthorised persons.
- The units are fixed and set up with sufficient slopes for drip water flow.
- The units are fixed and set up so that unobstructed air inlet/outlet is constantly available without any air short circuiting.
- The units are fixed and set up so that unobstructed heater rod exchange with electric defrosting is constantly available (option: accessory at customer's request).
- The units are fixed so that they can be inspected, checked and maintained from all sides at all times, i.e. there must be unobstructed access to the refrigerant-carrying and electrical components, connections and lines, the pipeline labelling must be identifiable and adequate space must be available for testing.
- The working fluid-carrying lines must be protected against mechanical damage. On-site connections: when installing keep the unit free of load; force must not be exerted on the distribution and header pipes.
- The following must be observed without fail when installing the unit:
 - Provision of measures to safeguard people from a CO₂ concentration of more than 5,000 ppm (MAC value).
 - Set up and fix units as follows: In areas that are used for inner-plant traffic, the pipelines to and from the unit must be installed only with connections and fittings that cannot be removed.
 - Release devices to prevent liquid escapes must be provided and available.

2.11 Residual hazards with break during operation

WARNING

Injuries and damage to property caused by break during operation!

- Defective installation ([see Residual hazards caused by defective installation, page 28](#)).
- Non-compliance with maximum permissible operating pressure ([see Operating conditions, page 19](#)).
- **Caution!**CO₂ evaporators, of the CPGHN.2 series work with a very high operating pressure. Danger from high operating pressure: 50 bar! Breakage of pressurised pipes or pressurised components in the unit can cause injuries or damage to property from flying debris ([see Residual hazards caused by pressurised parts, page 27](#)).

- Disregarding pressurised line sections with maintenance ([see Residual hazards caused by pressurised parts, page 27](#)).
- Disregarding residual hazards caused by vibrations ([see Residual hazards caused by vibrations, page 27](#)).

result in ruptures during operation and maintenance. This results in dangers caused by

- escaping materials ([see Residual hazards caused by pressurised parts, page 27](#)).
- released working fluid ([see Residual hazards due to carbon dioxide \(CO₂\), page 25](#)).

Ensure that:

- The installation is fault-free.
- The maximum permissible operating pressure is always adhered to.
- Pressurised line sections are de-pressurised before all maintenance and repair work.
- Vibrations from the refrigeration system, from the (vibrations caused by system compressors, , components and lines) and from the fan (imbalances caused by frosting, icing or dirt build-up or damages) are reduced with all available means and brought down to an absolute minimum.

2.12 Residual hazards caused by escaping objects or liquids

WARNING

Injuries and damage to property caused by escaping objects or liquids!

Residual hazards caused by escaping objects and liquids ([see Residual hazards with break during operation, page 29](#)).

2.13 Combined residual hazards

2.13.1 Removable side plates/

WARNING



Danger of frostbite!
Danger of hand injuries!

With unauthorized access into the opened unit there is the danger of frostbite if heat exchangers or pipes are touched, and the danger of cuts on sharp edges.



The removable side plates, must only be opened by trained specialist staff with suitable tools (sizes 040.2, 045.2, 050.2 with screw drivers) and only for maintenance and repair purposes. Close the removable side plates, after the work is completed and secure them against unintentional or unauthorised opening!

2.14 Residual hazards with disposal

WARNING

Danger of injuries and damage to property caused by working fluid, , CO₂!

The following notes are recommendations for the proper professional disposal of the unit. Applicable waste disposal laws are binding for the country of operation:

- Disposal must only be carried out by experts.
- All unit components, e.g. working fluids, refrigerator oil, heat exchangers, fans, must be disposed of properly as specified.
- Used working fluid that is not determined for reuse, must be treated as waste and safely disposed of. There must be no emissions into the environment.
- The CO₂ refrigerant must be filled into a special refrigerant container in compliance with the respective safety measures. This special refrigerant container must be suitable for the CO₂ refrigerant. It must be easy to identify and labelled for the refrigerant, e.g. "Carbon dioxide (CO₂) recovered".
- A disposable single-use container must not be used, as refrigerant vapour residues in the container escape during disposal.
- The working liquid receiver must not be overfilled. The maximum permissible pressure of the working fluid container must not be exceeded during the work process.
- The working fluid must not be filled in a liquid container that contains another or an unknown working fluid. This other or unknown working fluid must not be released into the atmosphere, but rather identified, treated again, or properly disposed of as specified.
- An officially authorised facility can be used for destroying the working fluid.
- It must be ensured that all unit components containing working fluids and refrigerator oil, are disposed of properly as specified.
- The unit consists predominantly of the basic materials, stainless steel, aluminium, (heat exchangers and casings), steel and aluminium, copper, polyamide (motors), steel, copper, insulating material (heater rods with electric defrosting – option; accessory at customer's request). These materials can be handled by the waste industry, including in paint-treated state, to recycling via mechanical and thermal separation.
- Before scrapping the working fluid-carrying unit components must be drained, whereby the pressure must be reduced to at least 0.6 bar absolute for a unit pipe volume up to and including 200 l, and to 0.3 bar absolute for a unit pipe volume over 200 l. The pressure reduction process is then ended when the pressure no longer increases and remains constant, and the unit is at ambient temperature.

WARNING

Danger of environmental damage!

Carbon dioxide (CO₂) is a greenhouse gas that appears in the most important natural compounds. Additional emissions from anthropogenic sources result in serious global warming and therefore damage to the global climate:

- As an important, climate-relevant trace gas, carbon dioxide (CO₂) contributes significantly to regulation of the earth's heat balance. Carbon dioxide (CO₂) changes the earth's radiation balance by allowing (almost unobstructed) the short-wave solar radiation to pass through to the earth's surface, and by partially absorbing the long-wave heat radiation emitted by the earth.

At 50 %, carbon dioxide (CO₂) is one of the most significant anthropogenic greenhouse gases

- Ensure that carbon dioxide (CO₂) never enters the atmosphere uncontrolled!

Güntner GmbH & Co. KG's transportation packaging is made from environmentally compatible material and is suitable for recycling.

3 Technical data

3.1 Unit

NOTICE

The fans' capacity values depend on the ambient temperature and on the air resistance at the set-up point.

Güntner GmbH & Co. KG recommends electric fan ring heating with use in the temperature range.

Please consult the manufacturer when operating the unit below -40°C because of the special material requirements and selection.

All electrical parts must be installed in accordance with EN standards.

Project number	See order-related documents
Unit name	See order-related documents
Manufacturer number	See order-related documents
Production year	See order-related documents
Working fluid	R 744 (carbon dioxide, CO ₂)
Volume	See order-related documents
Permissible operating pressure	50 bar
Test pressure	71.5 bar
Permissible ambient temperature	-30- +45 °C
Permissible air humidity	> 100%
Test date	See order-related documents
Test medium	Water
Airborne noise emitted	See order-related documents In accordance with the standard procedure for calculating sound level described in EN 13487; Annex C (normative).
Weight	See order-related documents

3.2 Fans

The fans' technical delivery conditions comply with DIN 24166, accuracy class 2.

Fan type	See order-related documents
Protection rating	IP 54, ISO F and DIN VDE 0530
Current type	Rotating or alternating current
Voltage	400 V 3~ 50 Hz or 230 V 1~ 50 Hz
Balancing quality	Q 6.3 in acc. with VDI 2060
Permissible air temperature	Usage range: -30°C to +45°C

Protective devices	<ul style="list-style-type: none">• Thermal: Thermo-contacts (temperature monitor for safeguarding against thermal overload).• Mechanical: Protective contact grille in acc. with EN 294
--------------------	---

4 Set-up and function

The air cooler consists of,

- a heat exchanger arranged as consisting of pipe coils fitted with fins distribution and header pipes (stainless steel)/ and pipe connections to the pipeline system,
- a casing, up to size 500 (fan diameter) made of sea-water resistant aluminium; powder-coated RAL 9003 (signal white), from size 710 made of galvanized sheet steel, powder-coated RAL 9003 (signal white),
- a thermally-decoupled and therefore condensation-free drip tray made of AlMg, powder-coated RAL 9003 (signal white). The drip tray is hinged and removable for easier cleaning. Problem-free condensation water drain; 45° drain nozzles mounted using flat-sealing G threads as described in DIN ISO 228-1,
- a drip tray made of AlMg, powder-coated RAL 9003 (signal white). The drip tray is hinged and removable for easier cleaning. Fault-free condensation water drain with optimally arranged flow. 45° drain nozzles mounted with flat-sealing G threads as described in DIN ISO 228-1,
- and – depending on the version – with one or more axial fans with maintenance-free motors. Two fan versions are possible here: normal and boosted (optional). High throw distances can be achieved with Guntner streamers.
- and – depending on the version – with one or more axial fans with maintenance-free motors. Hinged side cover provides easy access to the connections.

The evaporator is a refrigeration system component. It provides a finned heat exchanger (straight and curved pipes – pipe coils – with fins, which are connected to form a heat exchanger) in which liquid refrigerant evaporates by absorbing heat from the material to be cooled.

The refrigeration system is a combination of refrigerant-carrying components and fittings connected with one another, which form a closed circuit, in which the refrigerant circulates.

The refrigerant absorbs heat at a low temperature and low pressure and evaporates (evaporator-side), and at a higher temperature and higher pressure gives off the heat again and condenses itself (condenser-side).

The heat from the material to be cooled is dissipated with fans over the entire surface of the evaporator.

The CPGHN.2 series evaporators standardly operate in accordance with the “dry evaporation” principle. The refrigerant liquid fed to the evaporator is completely evaporated in it, and overheated to protect the compressor from slugging.

CO₂ evaporators in the CPGHN.2 series standardly operate according to the principle of flooded evaporation, i.e. the volume of liquid refrigerant that is introduced into the evaporator is from two to five times the charge that would be needed for complete evaporation. The refrigerant is fed to the CO₂ evaporator via pumps (pump-forced circulation). A liquid separator separates the liquid-vapour mixture of the refrigerant so that only the pure refrigerant vapour reaches the compressor. The liquid separator also ensures that the boiling refrigerant liquid is fed safely to the evaporator. The CO₂ refrigerant used is a Group L1/A1 refrigerant ([see Residual hazards due to carbon dioxide \(CO₂\)](#), [page 25](#)).



5 Fan motor

NOTICE

During longer periods of storage or standstill, the fans must be activated during 2 to 4 hours per month.

NOTICE

For fans with the protection rating IP55 or higher, existing closed condensation water holes must be opened at least once every six months.

AC technology

The AC motors are protected against overheating by a thermocontact (or PTC resistor).

For motors with a thermocontact, the thermocontact must be switched in such a way that the motor cannot be powered on when the thermocontact is triggered. A locking mechanism is recommended to prevent renewed power-on.

Motors with a PTC resistor need an additional external trigger unit for the installed thermistors. A locking mechanism is recommended to prevent renewed power-on. The test voltage at the thermistors is not permitted to exceed 2.5 V, or only current-limiting test devices may be used.

When using a star-delta connection, a corresponding delay must be considered.

For motors with direct starting and a connection value > 4.0 kW, an inrush current limitation (soft start using a thyristor) could be required.

If frequency converters are to be used for speed control, the following points must be considered for external rotor fans:

Between the frequency converter and fans, all-pole sine-wave filters must always be installed (sine wave-shaped output voltage; filter effect between phase to phase and phase to earth).

All GÜNTNER frequency converters are equipped with this function as standard. Conventional three-phase motors are suitable for direct operation with frequency converters.

With star-delta connection, the three-phase fan motors can be operated with two speeds or with speed control. The direction of rotation must be checked. A change in the direction of rotation, if it is wrong, is made by interchanging two phases.

6 Transportation and storage

6.1 Safety

WARNING

Crushing danger with falling down!

The unit weighs between 50 kg and 900 kg. It can slip and fall off the transporting device, causing serious injuries or death. Heavy impacts or vibrations can damage the unit.

Ensure that the assigned staff is trained for proper unloading.

Ensure that nobody is under the unit or near the loaded area during the transport.

Ensure even weight distribution. Ensure that the bulk of the weight is always on the fan side. Observe the transport labels on the packed unit ([see Other signs and notes on the unit, page 15](#)).

Secure the unit against slipping and mechanical damage.

When transporting by crane: The hooks and lifting gear of the load lifting equipment must be only attached at the points specified by the manufacturer. Ensure that the unit casing is not crushed by slings.

Use auxiliary transport equipment where required. Use a transporting device appropriate for the unit's weight. You will find the weight of the unit in the order-related documents [see Set-up and other applicable documents, page 7](#)). Do not use connection pieces and header pipes as hooking points for lifting, pulling, fixing or mounting. This can cause leaks.

Transport the unit carefully. Particularly avoid setting the unit down hard.

6.2 Transportation and storage

NOTICE

Read and observe all transport signs on the units' packaging!

Prolonged mechanical stresses caused by uneven road surfaces and potholes and vibrations during transport by ship can cause transportation damage. Before transportation by sea or in countries with difficult transport routes, attachment parts that are likely to vibrate – in particular fans and base stands – must be removed for transportation.

- ▶ Use suitable equipment to transport the packed unit to the destination installation site (for example, a crane or fork-lift).
- ▶ Unload the unit.

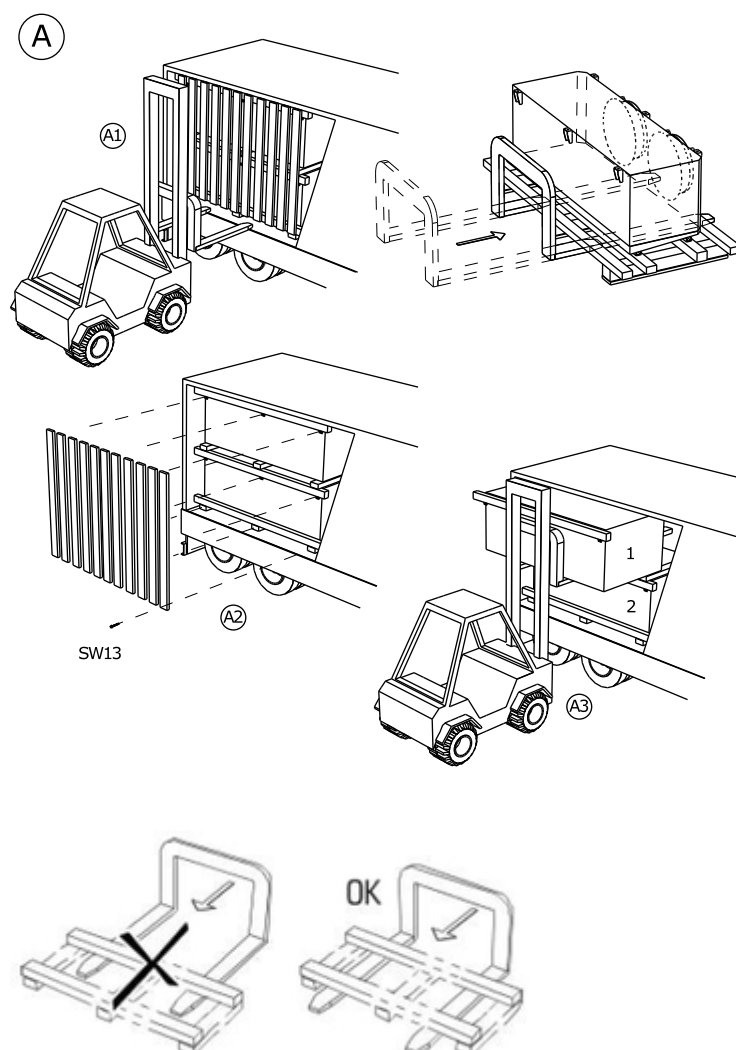

6.3 Storage before installation

NOTICE

Danger of corrosion and dirt build-up!

Moisture and dirt must be prevented from entering the unit.

- ▶ Protect the unit against dust, dirt, moisture and wetness, damage and other harmful effects. Harmful effects: [see Safety instructions for set-up and start-up, page 39](#)
- ▶ Do not store the unit for longer than necessary. Only store the units in their original packaging until installation. Always only place packaging units of the same size on top of one another.

- ▶ Store the unit at a protected place free of dust, dirt, moisture and damage-free until its set-up (well-ventilated halls or roofed storage site).
- ▶ If the unit set-up is delayed with regard to the planned installation time: protect the unit against weather and other harmful effects and dirt and other contaminants with an appropriate cover. The unit must also be well-ventilated here.

7 Set-up and start-up

7.1 Safety

7.1.1 Safety instructions for set-up and start-up

WARNING

Danger of injuries and damage to property with escaping CO₂ refrigerant!

Incorrect installation causes the danger of working fluid escaping when the unit is operated and injuries or damage to property ([see Residual hazards due to carbon dioxide \(CO₂\), page 25](#)).

Follow the set-up instructions in this chapter precisely and apply extreme care!

WARNING

Caution!

CO₂ evaporators, of the CPGHN.2 series work with a very high operating pressure. Danger from high operating pressure: 50 bar!

Breaks in pressurised tubes or pressurised components of the unit can cause injuries or damage to property caused by flying debris ([see Residual hazards caused by pressurised parts, page 27](#)).

NOTICE

Damage to the system's !

Foreign materials and contaminants in the working fluid circuit can impair the effectiveness or damage components. Particularly harmful contaminants are:

- Moisture
- Atmospheric air
- Welding residues
- Rust
- Soot/ash/cinders
- Metal cuttings
- Unstable oils
- Dust and dirt of all kinds

Moisture in the working fluid-carrying components of the unit can have the following consequences:

- Water separation and ice formation cause faults in the switching and control fittings of the refrigeration system
- Acidification
- Ageing and refrigerator oil decay
- Corrosion

Atmospheric air and other non-condensable gases can have the following consequences:

- Refrigerator oil oxidation
- Chemical reactions between working fluid and refrigerator oil
- Increased condensing pressure in the system

Chemical reactions between working fluid and refrigerator oil with the absence of moisture or atmospheric air with ageing and working fluid and refrigerator oil decay can have the following consequences:



- Formation of organic and inorganic acids
- Increased compressed gas temperature in the system
- Corrosion
- Bad lubrication, increased wear and tear through to system or failure

Other contaminants can cause:

- Accelerated chemical processes (decomposition)
- Mechanical and electrical faults in the refrigeration system

During the installation (connecting the working fluid-carrying components of the unit to the working fluid-carrying system of the installation's ensure that internal contamination is strictly avoided.

Perform the installation with extreme cleanliness.

Caution! Low permissible water content in a CO₂ refrigeration system! Ensure that the unit's level of dryness corresponds with the low permissible water content in a CO₂ refrigeration system!

Finish all on-site pipe installation work before releasing the transport pressure!

Only release the transport pressure on the Schrader valve immediately before installation.

Only remove the sealing caps on the distribution and header pipe immediately before installation.

NOTICE

Danger of corrosion and dirt build-up!

Moisture and dirt must be prevented from entering the unit. If moisture and dirt penetrate the unit there is also the danger of damage to fittings and other system components of the .

Protect the unit against dust, contamination, moisture and wetness, damage and other harmful influences. Harmful influences are, for example:

- Mechanical: Damages caused by impacts, objects falling on or against, collisions with transport equipment, etc.
- Physical: Damages caused by close by concentrated flammable gases
- Chemical: Damages caused by contaminated atmospheres (salt, acid, chlorine, sulphur-containing, or similar)
- Thermal: Damages caused by close by heat sources

Begin with the installation as soon as possible.

⚠ WARNING

The electrical installation may be performed only by electricians (or by expert technicians with appropriate qualifications) in compliance with the relevant VDE rules (or applicable national and international regulations) and the TCCs of the EPCs!

7.1.2 System-side safety requirements

The unit is a component of an installation and can only be operated in conjunction with the installation

- All equipment required for operating the unit must be integrated into the switching and activation equipment :
 - Electrics: Fans and other electrical components, heating rods for electrical defrosting (optional) if applicable,
 - Working fluids: valves and fittings
 - Drip water: drip water drain line

- The working fluid-side and electrical connections must be available on the system. The connections must be specified in the order-related documents.
- The power supply of the fans must be provided in acc. with the specifications on the type plate on the fan motors.
- A switch-off device for preventing unexpected start-up (repairs switch), which separates all active conductors from the power supply (all-pole switch-off), must be provided for the fans in acc. with EN 60204-1.
- The fans' switch-on/off device must be secured (e.g. with a padlock) to prevent uncontrolled fan start-up.
- The electrical motor, repairs switch, terminal box and switching cabinet connections must be provided in acc. with the respective connection diagrams.
- It must be possible to shut off the unit if a leak occurs.
- People wearing ambient air-independent breathing apparatus in full protective clothing must also be able to activate all safety-relevant shut-off fittings.
- It must be possible to activate all devices meant for diverting escaping working fluids from a safe position.

⚠ WARNING

Caution!

CO₂ evaporators, of the CPGHN.2 series work with a very high operating pressure. Danger from high operating pressure: 50 bar!

Breaks in pressurised tubes or pressurised components of the unit can cause injuries or damage to property caused by flying debris ([see Residual hazards caused by pressurised parts, page 27](#)).

7.1.3 Customer-side safety precautions

⚠ WARNING



Danger of injuries and damage to property!

The unit contains CO₂ refrigerant ([see Residual hazards due to carbon dioxide \(CO₂\), page 25](#)).



CO₂ is an irritant gas and causes agitation, dizziness, vomiting and cramps, with high concentrations causing suffocation and life-threatening pulmonary oedema.

Irritation of the respiratory centre with 30,000 to 50,000 ppm (3 to 5 vol %). Unconsciousness with 70,000 to 100,000 ppm (70 to 100 vol %).

There is no imminent danger for the staff. However, refrigerants of the Group L1/A1 are generally heavier than air and may flow off to rooms on a lower level. In still air there may be an increase of the ground level concentration. With high concentrations, there is a danger of suffering from disordered cardiac rhythm and suffocation due to a reduction of oxygen concentration, especially at ground level.

- Ensure that unauthorised persons do not have access to the unit.
- Ensure that the refrigerant escaping from the unit cannot penetrate the interior of the building or put people at risk in any other way.
- Comply with the requirements of EN 378-3 for refrigerants, filling weight and cold transfer systems.
- Install the unit in accordance with EN 378-1 only in the commissioned configuration and only in a set-up room that the unit manufacturer has configured the unit for.
- Install the unit in accordance with EN 378-3, section 5 in a special machine room if a CO₂ concentration of more than 5000 ppm (MAC value) could endanger the work

environment. Take effective protective precautions if such a spatial separation were to be required, but is not possible.

- Install the unit so that the MAC value – 5,000 ppm – as 8 h mean value is not exceeded. A concentration of 10,000 ppm (instantaneous value) for 60 min. three times per shift is permitted as peak limit.
- Install the electrical equipment (for fan operation, for ventilation, for lighting and for the alarm system) in the set-up room while observing the condensation of moisture and formation of drip water, as well as the risk level of CO₂ refrigerant in accordance with EN 378-3; section 6.
- Arrange CO₂ refrigerant detectors and alarm systems to warn of CO₂ refrigerant concentrations that are hazardous to health and for control purposes at the unit set-up point in accordance with EN 378-3; section 7.
- Ensure that the unit at the set-up point is not exposed to any inadmissible high temperature effects. Effectively protect the unit against heat sources or temporary high temperatures.



Caution!

CO₂ evaporators, of the CPGHN.2 series work with a very high operating pressure. Danger from high operating pressure: 50 bar!

Breaks in pressurised tubes or pressurised components of the unit can cause injuries or damage to property caused by flying debris ([see Residual hazards caused by pressurised parts, page 27](#)).

WARNING

Danger of environmental damage!

Carbon dioxide (CO₂) is a greenhouse gas that appears in the most important natural compounds. Additional emissions from anthropogenic sources result in serious global warming and therefore damage to the global climate:

- As an important, climate-relevant trace gas, carbon dioxide (CO₂) contributes significantly to regulation of the earth's heat balance. Carbon dioxide (CO₂) changes the earth's radiation balance by allowing (almost unobstructed) short-wave solar radiation to pass through to the earth's surface, and by partially absorbing the long-wave heat radiation emitted by the earth.

At 50%, carbon dioxide (CO₂) is one of the most significant anthropogenic greenhouse gases

- Ensure that carbon dioxide (CO₂) never enters the atmosphere uncontrolled!

7.2 Requirements at the set-up point

You will find the dimensions and weights in the order-related documents.

- ▶ Position the unit so that it cannot be damaged by internal traffic or transport processes.
- ▶ Enable optimum unit control and accessibility:
 - Place the unit so that it can be monitored and controlled from all sides at all times.
 - Ensure that sufficient space is provided for maintenance.
 - Ensure that all liquid-carrying components, connections and lines and all electrical connections and lines are easy to access.
 - Ensure that the pipes' identification is well visible.
 - Ensure that the free space at the side of the unit (e.g. the side distance from the unit to any possible obstructions) is large enough so that the hinged side plates can be opened without

introducing any hazard or obstruction.

- Ensure that the free space in front of the unit (e.g. the distance from the unit to any possible obstructions in front of the unit) is large enough that the swivel fans (optional) can be accessed without introducing any hazard or obstruction.

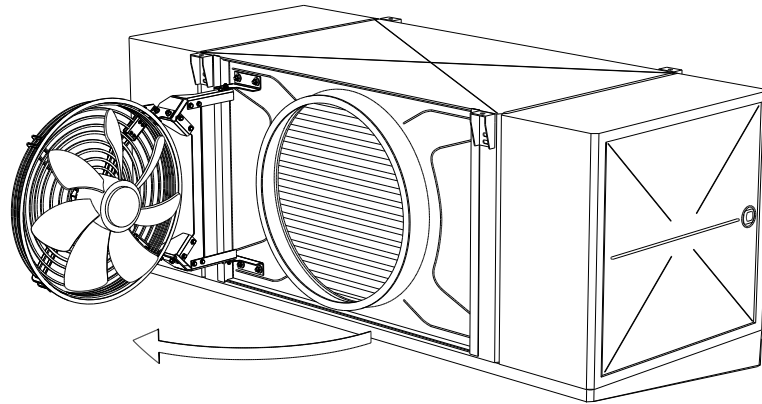

- Ensure that units with electric block defrosting (option: accessory at customer's request) have enough space for changing heater rods.

7.3 Unpacking the unit

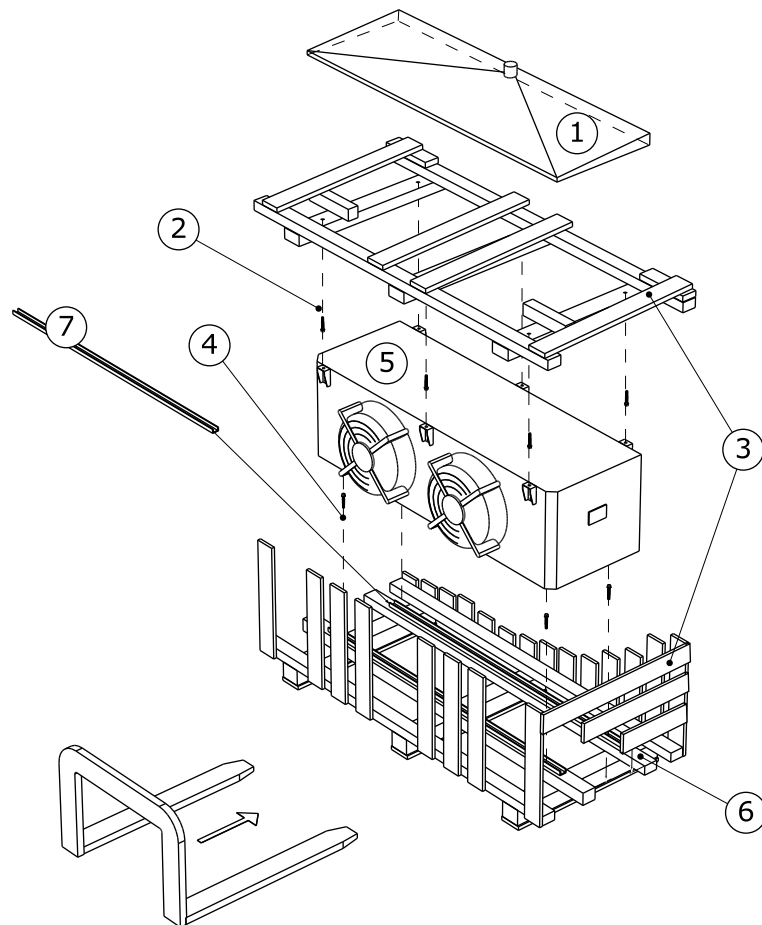

- ▶ Remove the tray (1 – packed in bubble wrap): Remove anti-slip safety.
- ▶ Remove attachment bolts on timbers (2, 4 and 5).
- ▶ Remove transport frame (3) consisting of timbers and form boards. The transport frame then serves for lifting the unit (including mounted drip tray) when installing at the set-up point.
- ▶ Remove front plate bolts on palette (6).
- ▶ Remove unit from packaging: When lifting insert the forks under the spacer strip (7), as the spacer strip protects the electric heater rods. The spacer strip is mounted under the hotplate between the hotplate and the drip tray.

CAUTION! The transport medium's capacity must be at least 1.5-times the weight of the unit.

The units are delivered packed in the installation position with mounted tray.

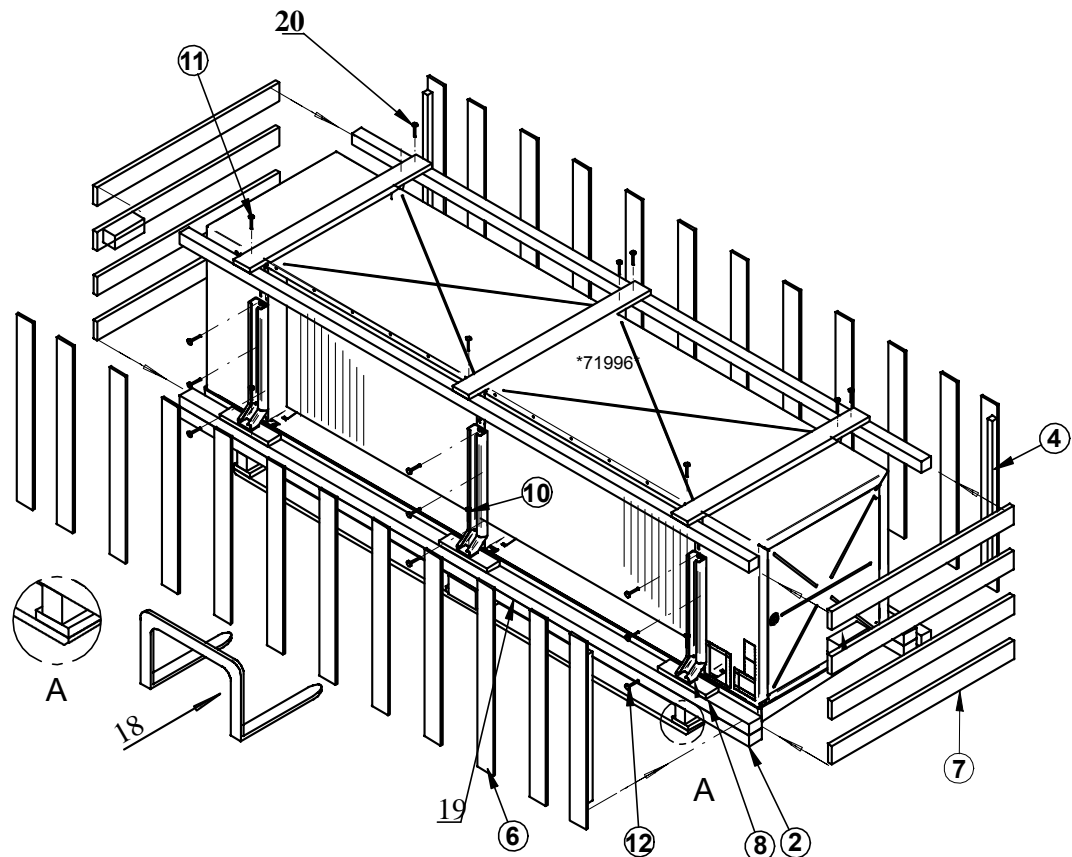

- 18 Forklift use
 19 Blanking plugs included
 20 Timbers 3 and 4 bolted with wood bolts

- ▶ The units are delivered packed in the installation position with mounted tray.
- ▶ Remove transport protection (timbers 3 and 4 bolted with wood bolts 11 and form boards 6 and 7).
- ▶ The transport frame (timbers 1 and 2, bolted with wood bolts 10 with transport leg 8 of the unit, bolted with hexagonal bolt 12 with the unit) then serves for lifting the unit (including the mounted drip tray) when installing at the set-up point (see [Mounting the unit, page 49](#)).
- ▶ The blanking plugs 19 included with delivery serve with the installation for closing the fixing holes for the transport legs.
- ▶ Remove unit from packaging: When lifting insert the forks under the transport frame, as this protects the drip tray. The units are delivered in the installation position with mounted drip tray.
CAUTION! The transport medium's capacity must be at least 1.5-times the weight of the unit.

- ▶ Check the delivery for completeness. You will find a list of the contents of the package in the order-related documents.
- ▶ Any transport damage and/or missing parts must be recorded on the bill of delivery. The facts must be immediately reported to the manufacturer in writing. Damaged fins can be straightened on-site with a fin comb.
- ▶ The units are delivered packed in the installation position.
- ▶ Check transport overpressure: The units are delivered from the manufacturer with approx. 1 bar transport overpressure (cleaned and dried air). Read the transport pressure on the Schrader valve (pressure measurement). With unpressurised unit: Immediate report to manufacturer and noting on bill of delivery. An unpressurised unit indicates a leak on the unit!
CAUTION! Danger of injuries and damage to property with escaping working fluid!
An unpressurised unit indicates a leak due to transport damage. Escaping working fluid through leaks on the unit can cause injuries or (see [Residual hazards due to carbon dioxide \(CO₂\)](#), page 25). Do not put the unit into operation!
- ▶ Check transport pressure and release (only immediately before installation).
- ▶ Remove blanking plugs.

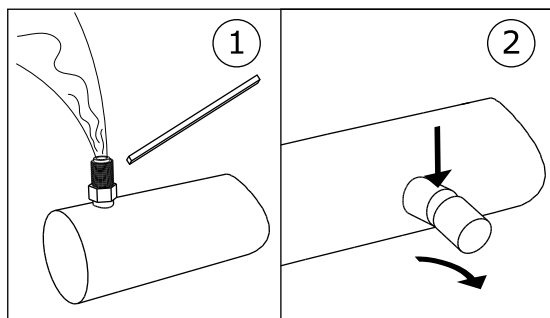

1: Check/release transport overpressure / 2: Remove blanking plugs.

NOTICE

Danger of corrosion and dirt build-up!

Moisture and dirt must be prevented from entering the unit.

Protect the unit against dust, dirt, moisture and wetness, damage and other harmful effects. Harmful effects: [see Safety instructions for set-up and start-up, page 39](#)

Begin with the installation as soon as possible.

7.4 Installation

7.4.1 System-side requirements for stress-free installation

- ▶ Prevent stresses in the unit:
 - Ensure that all fixing points have the same spacing to the fixing level.
 - Ensure that all fixing points maintain the same spacing to the fixing level under load and permanently.
- ▶ Set up and fix units as follows: Airflow must not be impaired by obstructions.

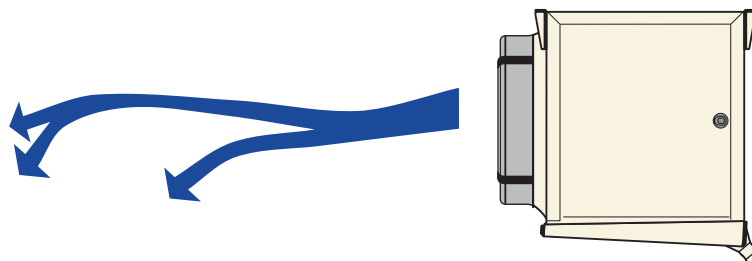

- ▶ The units must be installed on fixing points that are appropriate for the unit's weight and then bolted with fixing bolts. The operator or installer of the equipment is responsible for ensuring that the bolted connections are of an adequate strength. The following instructions must be observed when fixing the units:
 - The diameter of the mounting holes have been statically determined by the manufacturer; the fixing bolts must be adapted accordingly. When calculating the transferring bearing strength it is imperative to take into account the total weight of the unit (= structural weight + weight of pipe content + additional weight, such as water, frost, ice, dirt or similar).
 - The fixing bolts must be secured against loosening with an appropriate locking device.
 - The fixing bolts must not be overtightened or stripped.
 - All fixing bolts must be tightened equally.
- ▶ Prevent the unit from shifting in its position. Fix the unit in its position. Tighten the fixing bolts and secure them against loosening.

- ▶ Ensure that the drip water drains correctly. Set up the unit horizontally with a sufficient slope for the drip water run-off. The units are delivered in the installation position with mounted drip tray.
- ▶ Only fix the unit to the intended fixing points.

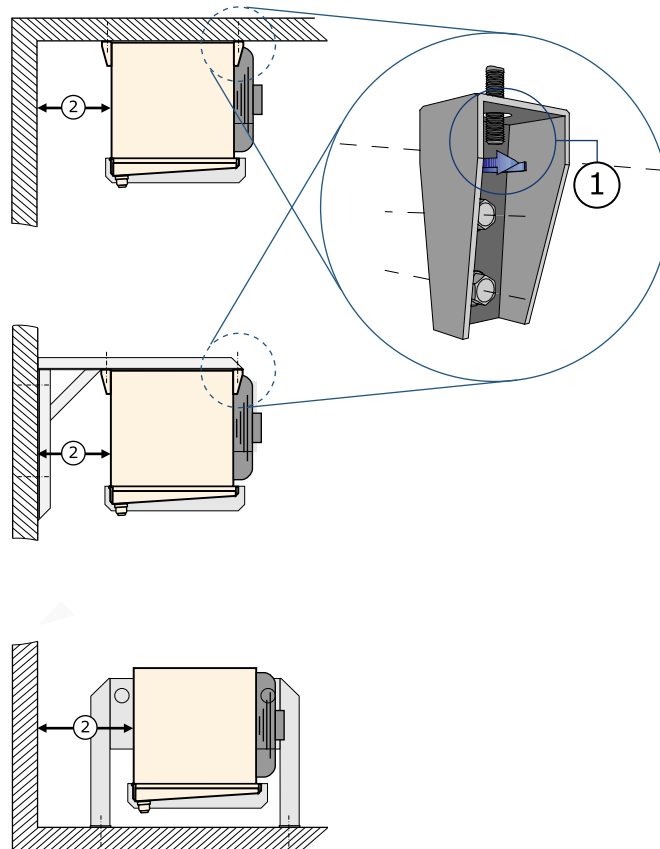

7.4.2 Mounting the unit

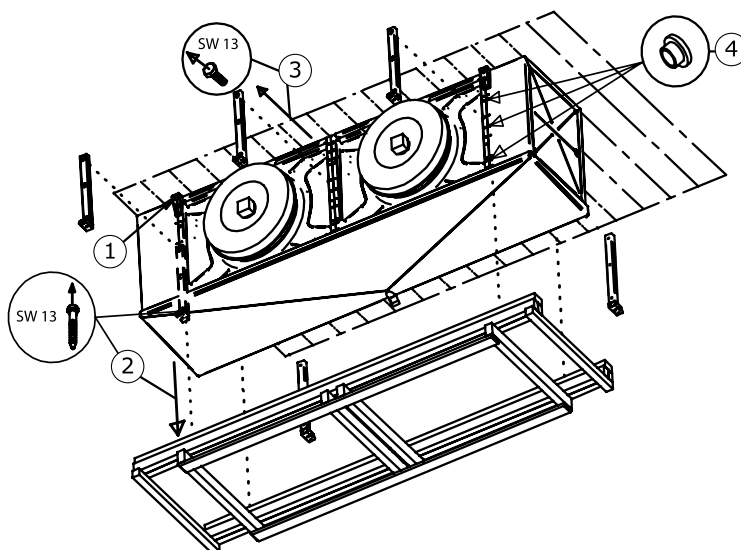

- ▶ Fix the unit on the intended fixing points (1). All fixing bolts must be tightened equally to achieve a load distribution that is as balanced as possible.
CAUTION! The fixing bolts must not be overtightened or stripped!
- ▶ The fixing bolts must be secured against loosening with appropriate locking devices.
- ▶ Remove bolts on transport frame (2).

7.4.3 Notes on mounting fan swivel unit (option)

Note on fixing material not included with delivery: Material/strength class and corrosion protection as selected by the customer.

NOTICE

Strength class 5.8 bolts and aluminium alloy bolts not permitted!

Mounting sequence on the unit (fan with fan grille is already mounted on wall ring plate):

- ▶ 1. Drill the 4 position holes in the fan plate at $\varnothing 13$ mm (if not already there), remove drill cuttings and apply corrosion protection to cut edges.
- ▶ 2. Remove fan.
- ▶ 3. Insert bolts into the wall ring plate at the intended positions. These connection elements are not included in the swivel unit scope of delivery and must be provided or procured separately. Intended for this are:
 - 4 hexagonal bolts ISO 4017-M12x40
 - 8 washers ISO 7093-1-12
 - 4 hexagonal nuts ISO 4032-M12
- ▶ 4. Mate washers ISO 7093-1-12 with threaded bolts.

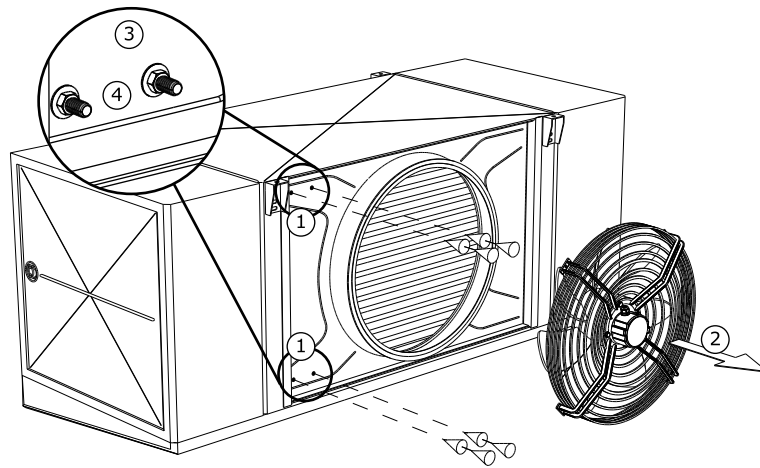

- ▶ 5. Fold up hinged part of the swivel unit until it stops.

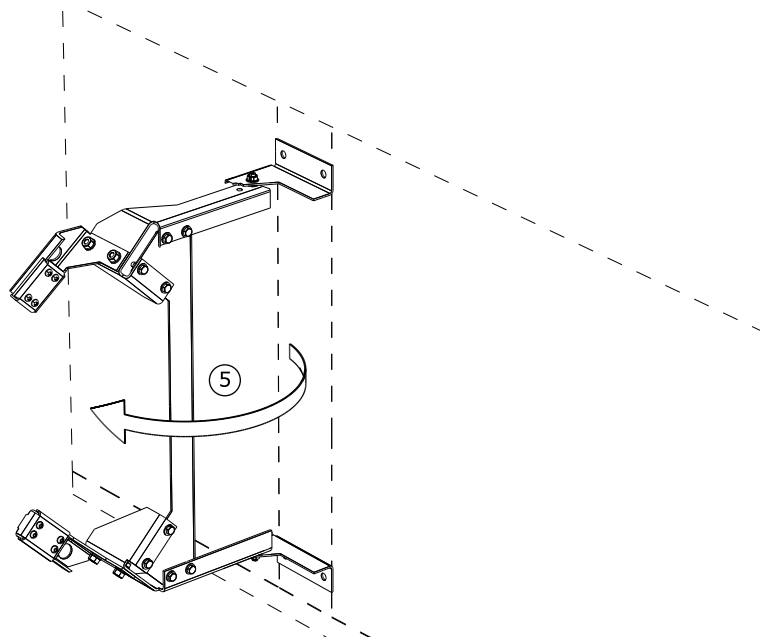

- ▶ 6. Remove the two holding plates for fixing the fan grille to the swivel parts of the swivel unit module by screwing out the 4 bolts.
- ▶ 7. Set the fan into the top hinge part of the swivel unit. Align the top hinge part on the support braces of the bracket (front fixing bolts of the top hinge part are pushed through between the 2nd and 3rd grid slots of the fan grille).
- ▶ 8. Align the holding plate on the underside of the bracket and fix with the wrench/screwdriver accordingly.

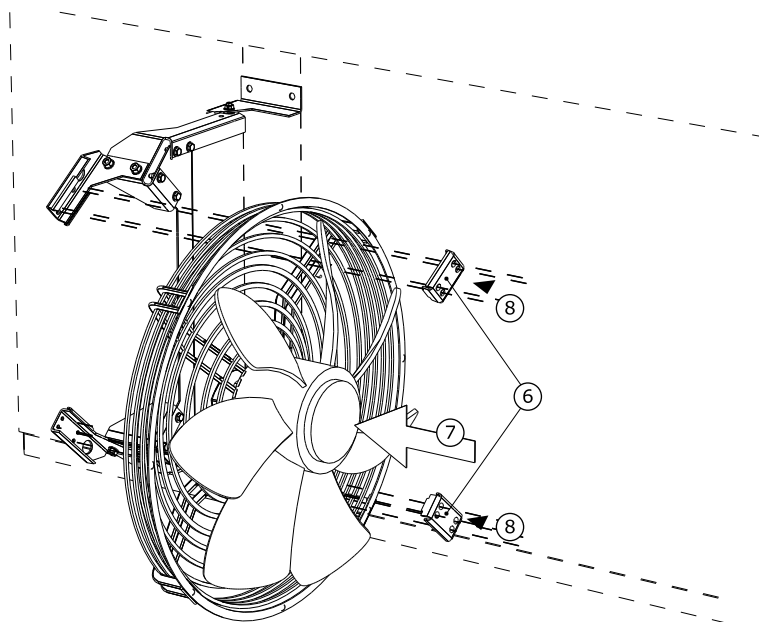

- ▶ 9. Fix swivel unit with pre-mounted fan on the bolts named under 3.

NOTE! Tighten nuts hand-tight only!

Intended for this are:

- Washers ISO 7093-1-12
- Bolt lock (e.g. thrust washer)
- Hexagonal nuts ISO 4032-M12

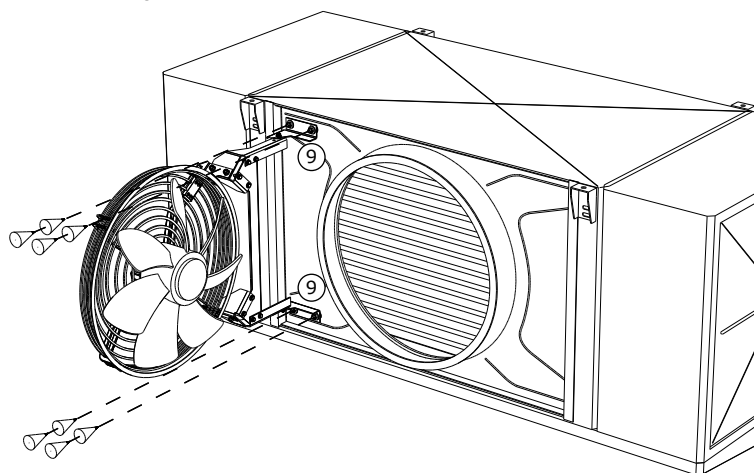

- ▶ 10. Swing fan into the duct.
- ▶ 11. Align fan and tighten to duct.
- ▶ 12. Tighten bolt connections of the swivel unit (exception: bolt connection under 9).

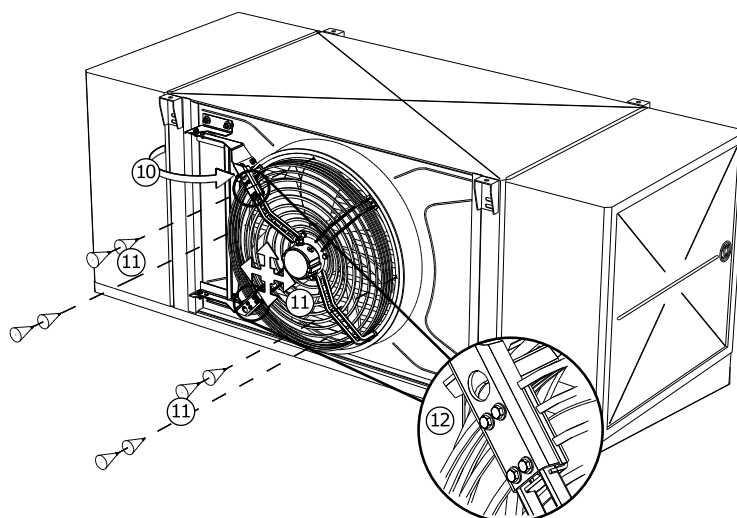

- ▶ 13. Loosen fan bolts again.
- ▶ 14. Push complete unit up to avoid dropping down when opened.
- ▶ 15. Tighten the nuts named under 9.

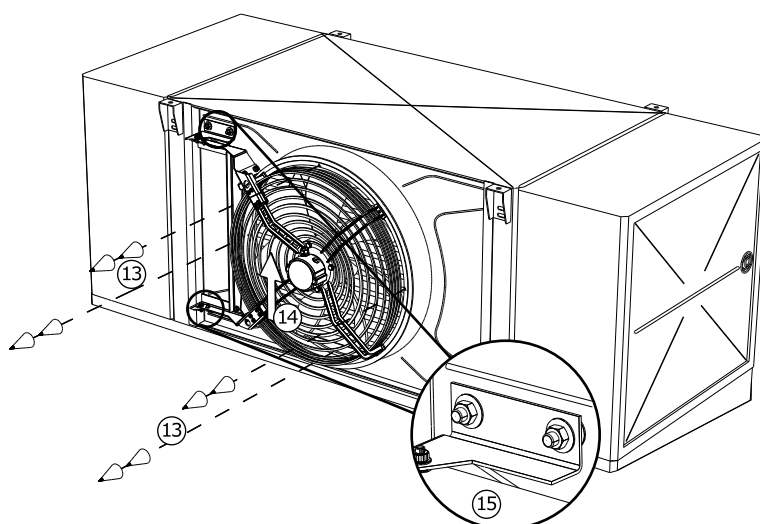

If the clamping part of the swivel unit does not lie exactly on the supports or the fan fixings do not match up, proceed as follows:

- ▶ 10.a) Loosen bolt connections on the swivel unit.
- ▶ 10.b) Align top hinge part on the supports and fan on the duct.
- ▶ Then continue as under 11.

NOTE! Danger of damaging! Do not use excess force!

7.5 Notes on connecting the unit

WARNING

Danger of injuries and damage to property with escaping CO₂ refrigerant!

Incorrect installation risks working fluid escaping when the unit is operated, causing injuries or damage to property ([see Residual hazards due to carbon dioxide \(CO₂\), page 25](#)).

Prevent working fluid from escaping from the unit into the environment.

- Secure all working fluid-carrying lines against mechanical damage.
- In areas that are used for internal traffic, only lay the pipelines to and from the unit with connections and fittings that cannot be removed.

Ensure that the on-site connections do not exercise any forces upon the distribution and header points. This can cause leaks on the working fluid connection points of the unit and on connection points of the on-site pipe-laying.

Caution!

CO₂ evaporators, of the CPGHN.2 series work with a very high operating pressure. Danger from high operating pressure: 50120 bar!

Breaks in pressurised tubes or pressurised components of the unit can cause injuries or damage to property caused by flying debris ([see Residual hazards caused by pressurised parts, page 27](#)).

Ensure that:

- Release devices to prevent liquid escapes are provided and available.
- With refrigeration system shutdown state, under-cooled liquid is only present in the lowest possible amount in system components – minimized number of "fluid sacks".
- When switching over a duty pump to a reserve pump no liquid, cold working fluid remains in the pump.

7.5.1 Connecting the drain line to the drip tray

Please observe the following instructions with the installation:

- The following 4 pipe guides are recommended with:
 - Continuation to the front through 45° curve
 - Continuation down through 45° curve
 - Continuation to the right or left through 90° curve
- Connecting drain line seal with flat gasket pressed on the pipe connectors
- Cylindrical G thread 1¼" and 2" as described in DIN ISO 228-1:
 - Only seal with flat gasket!
 - Do not seal with teflon tape!
 - Do not seal with hemp!
- Do not tighten threaded connections with tools!
 - Do not use pipe wrench or any other wrench!
 - Tighten with the hand only!

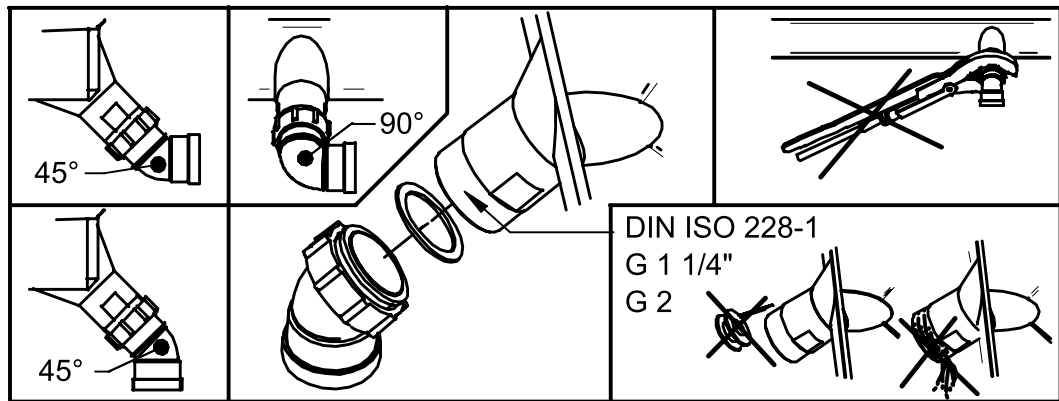

- ▶ Lay drain line completely strain-free. The diameter of the drip water drain line must be at least that of the drip water drain of the unit, and the drip water drain line should be laid with a slope (3 – 5°).
- ▶ Tighten connection nuts with the hand only!

NOTICE

Danger of damaging! The plastic threads can be damaged by over-tightening if you use a wrench. This results in leaks with drip water damage on the produce to be cooled. Do not tighten the connection nuts with a wrench!

7.5.2 Connect the unit to the system

⚠ WARNING

Danger of injuries and damage to property!

Improper connection to the the system causes hazards:

- Leaks result in escaping CO₂ refrigerant ([see Residual hazards due to carbon dioxide \(CO₂\), page 25](#)).
 - Soldering and welding work on pressurised parts can result in fires or explosions.
 - Ensure that stresses and vibrations from the system are not passed on to the unit.
 - Only lay working fluid-side connections stress-free! The on-site pipeline system must be braced before connecting to the unit!
 - Soldering work is only permitted on unpressurised units!
 - Soldering and welding work is only permitted on unpressurised units!
 - Evacuate the unit professionally in acc. with EN 378-2.
 - Ensure that the unit's level of dryness corresponds with the low permissible water content in a CO₂ refrigeration system!
 - The use of open fire at the installation site is forbidden. Fire extinguishers and extinguishing agents used to protect the equipment and the operating staff must comply with the requirements of EN 378-3.
 - Ensure that refrigerant detectors and alarm systems for warning about about health-endangering concentrations and for control purposes at the unit set-up point are arranged in acc. with EN 378-3; section 7.
- ▶ Install the pipes in acc. with EN 378-1 and EN 378-3. Ensure here:

- That the pipeline installation is kept as short as possible. Use as few bends as possible, and if bends are necessary, use big radii!
- Avoid transmitting vibrations to the unit via conduits or pipes. If necessary, use vibration dampers.
- Hot gas, Always lay the fluid supply and return lines separately from one another. Make sure they do not touch.
- Factory-fitted modules (optional) make installation easier. hot gas defrosting piping between drip tray and heat exchanger coil and mounted check valve with hot gas defrosting.
- The free space around the unit (e.g. the distance from the drip tray underside to any possibly existing pipe systems) must be big enough to ensure there is no danger to the unit; regular maintenance of the components must be possible, and it must also be possible to check and repair components, pipes and fittings.
- The free space around the unit must be big enough to ensure there is no danger to the unit; regular maintenance of the components must be possible, and it must also be possible to check and repair components, pipes and fittings.
- It must be possible to shut off the unit if a leak occurs. It must be possible to activate all devices used for diverting escaping working fluids from a safe position.
- Electrical components, e.g. for fan operation, for heater rod operation with electrical defrost, for ventilation, for illumination and for alarm system on installation site, have to be designed with regard to condensation of air humidity and droplet formation in acc. with EN 378-3; section 6.
 - ▶ All connections must be welded in acc. with stainless steel version/. Ensure here:
 - Prevent leaks, weld precisely and carefully!
 - Prevent overheating when welding (danger of excessive scaling)
 - Use shielding gas when welding (prevent excessive scaling)!
 - ▶ Caution! Low permissible water content in a CO₂ refrigeration system! Ensure that the unit's level of dryness corresponds with the low permissible water content in a CO₂ refrigeration system!

7.5.3 Unit electrical connection and protection

All fans with rotating current drive can be operated via D-S switch-over with two different speeds:

- D: high speed
- S: lower speed
- ▶ Connect fan motors in acc. with motor connection circuit and check connection.
- ▶ Provide power supply in acc. with the specifications on the fan motor's type plate:
 - The fan motors for the 400 mm and 450 mm fan diameters are operated in 1~ alternating current.
 - The fan motors for the 500 mm fan diameter are operated in 3~ rotating current.
- ▶ Connect thermo contacts for motor protection.
- ▶ Where required, connect electrical feeds for the heater rods for electric defrosting in accordance with electric connection diagram.

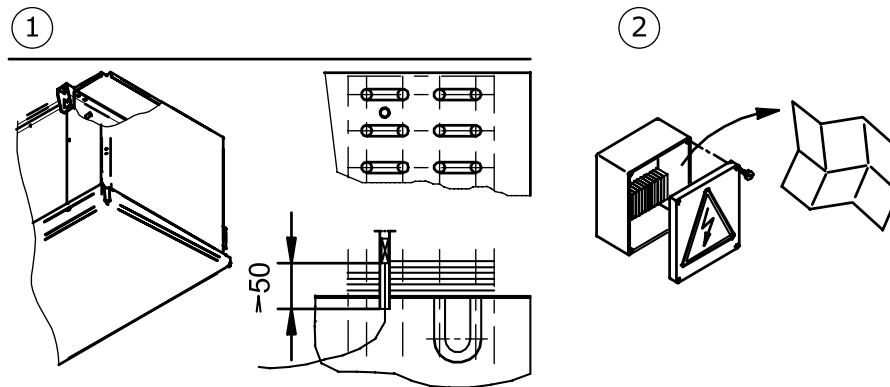

- 1 Defrost limit sensor position (if used)
- 2 Electrics (fan motor, stamp data, connection values)

- ▶ Seal all electrical lines to the connection boxes in acc. with their protection class. The connection class is specified in the order-related offer documents.

⚠ WARNING

Danger of damaging! If the fuse rating is too high there is the danger of injuries to people and damage to property.

Max. fuse rating for the defrost heater rods feed : see order-related offer documents. The supply lines must always be fused as appropriate for the smallest wire cross-section.

7.6 Perform acceptance test

⚠ WARNING

Danger of injuries and damage to property!

Escaping CO₂ refrigerant can cause injuries or even death ([see Residual hazards due to carbon dioxide \(CO₂\), page 25](#)).

CO₂ evaporators, gas coolers/condensers of the CPGHN.2 series work with a very high operating pressure. Danger from high operating pressure: 50 bar!

Breaks in pressurised tubes or pressurised components of the unit can cause injuries or damage to property caused by flying debris ([see Residual hazards caused by pressurised parts, page 27](#)).

Perform the following acceptance test with an expert before starting up the unit after making important changes and after a unit exchange.

- ▶ Ensure that the temperature and the air humidity at the set-up point correspond with the technical data ([see Technical data, page 32](#)).
- ▶ Ensure that sufficient air can be sucked in and released.
- ▶ Ensure that the supply feed is sufficient for the required energy. Compare the unit inside of the system with the plans of the system and the electrical wiring diagrams.
- ▶ Test the unit for vibrations and movements that can be caused by the fans and operation of the system. Remove oscillations, vibrations and movements following consultation with the manufacturer or independently.
- ▶ Perform visual inspection of the structural design, the brackets and fixtures (materials, sequence, connections), the ability to operate and the arrangement of the fittings.

- ▶ Check that the tray installation with safety catch is correct.
- ▶ Check and if necessary re-tighten all threaded connections, especially on the fans.
- ▶ Check installation of pipe connections.
- ▶ Check laying of working fluid-carrying connection pipes.
- ▶ Ensure that the unit is protected against mechanical damage.
- ▶ Ensure that the unit is protected against inadmissible heating up and cooling down.
- ▶ Check the fan blades protection.
- ▶ Ensure that optimum unit control and accessibility are guaranteed.
 - Is the unit placed so that it can be monitored and controlled from all sides at all times?
 - Is sufficient space provided for maintenance?
 - Are all liquid-carrying components, connections and lines and all electrical connections and lines easy to access?
 - Are the pipes easy to identify?
- ▶ Check heat exchanger surfaces for dirt and clean as required ([see Clean unit, page 68](#)).
- ▶ Perform function tests on the fans (rotation direction, power consumption, etc.).
- ▶ Check electrical connections of the fan motors and, where app., the heater rods with electric defrosting for damage.
- ▶ Check the quality of the welding connections, the electrical connections and the fixture connections.
- ▶ Perform pressure test with test gas and with a test pressure of 1.1-times the permissible operating pressure: check the connection seals and detect leaks, e.g. with foaming agent, or similar.
- ▶ Check corrosion protection: Perform a visual inspection on all bends, components and component holders that are not heat-insulated. Document and archive test results.
- ▶ Perform test run. Observe and check unit during test run, in particular for:
 - Fan smooth running (bearing noises, contact noises, imbalances, etc.).
 - Fan power consumption:
 - Leaks
- ▶ Report all defects to the manufacturer immediately. Remove defects following consultation with the manufacturer.
- ▶ Check the unit and the unit's interaction with of the system again after 48 operating hours, especially on the connections and on the fans, and document the test results.

7.7 Test readiness for operation

- ▶ Ensure that all electrical protective measures are ready to function.
- ▶ Ensure that all working fluid-carrying connections are securely in place.
- ▶ Ensure that all electrical connections (fans , if applicable heater rods for electrical defrost) are effected securely.
- ▶ Ensure that the unit connection to the drip water drain line is properly set up ([see Connecting the drain line to the drip tray, page 53](#)).

7.8 Putting the unit into operation for the first time

WARNING

Danger of injuries and damage to property!

Escaping CO₂ refrigerant can cause injuries or even death ([see Residual hazards due to carbon dioxide \(CO₂\), page 25](#)).

You can put the unit into operation, only when:

- The unit has been properly mounted and connected ([see Installation, page 46](#)).
- You have performed a complete acceptance test ([see Perform acceptance test, page 56](#)).
- You have checked the unit's readiness for operation ([see Test readiness for operation, page 57](#)).
- All safety precautions ([see Safety, page 39](#)) have been taken.

Caution! CO₂ evaporators of the CPGHN.2 series work with a very high operating pressure. Danger from high operating pressure: 50 bar!

Breaks in pressurised tubes or pressurised components of the unit can cause injuries or damage to property caused by flying debris ([see Residual hazards caused by pressurised parts, page 27](#)).

Follow the operating instructions manual of the system!

Contact the manufacturer immediately if you want to operate the unit under different operating conditions as those defined in the order-related offer documents.

- ▶ Switch on the system including of the electrical system (see system).
- ▶ Activate the unit:
 - Open the valves on the inlet and outlet-side system.
 - Activate fans
 - Put drip water waste line into operation
- ▶ Wait until the operating point is reached. After the operating point is reached the unit is ready to operate (see system).

Parameters for setting the operating point, see order-related offer documents.

Operating point:

- Evaporation temperature
- Airflow volume
- Air inlet temperature
- Relative air humidity

To ensure the specified operating point is complied with the actuators for the operating point setting must be secured against unauthorized access (e.g. by sealing, screwing on caps, removing hand wheels, etc.).

8 Operation

8.1 Safety

⚠ WARNING

Danger of cutting off, pulling in!



There is a danger of cutting off fingers on the rotating fan blades, injury hazard for the hands and pulling in danger with loose elements such as hair, necklaces or clothing parts.

Do not operate fans without guard grille!

Ensure that the optional swivel fan units are fixed and secured against unintentional or unauthorised opening.

⚠ WARNING

Danger of frostbite/burning!



Danger of frostbite or burns if the parts are touched ([see Thermal residual hazards, page 25](#)).

Do not touch any parts of the unit without protective gloves when the unit is in operation or if it has not yet warmed up or cooled down after operation.



8.2 Putting the unit into operation

To operate the unit the system including the electrical system must be in operation. The unit must be started up by opening the valves on the inlet and outlet side of the plant by connecting it to the electrical system and the drip water drain as described below (see system operating instructions manual):

- ▶ Switch on electrical system
- ▶ Open working fluid-carrying lines
- ▶ Switch on fans
- ▶ Put drip water waste line into operation

8.3 Taking the unit out of operation

The units are system components of a system. The unit is taken out of operation by switching off the system in accordance with the system operating instructions manual. The working fluid-carrying lines of the plant must be shut off here and the fans and, where applicable, the heater rods for electric defrosting must be disconnected from the electrical system (see system) operating instructions manual:

- ▶ Switch fans off
- ▶ Switch electrical system off
- ▶ Close working fluid-carrying lines
- ▶ **NOTE! When shut down consider max. operating pressure! If necessary, take precautions to ensure that it cannot be exceeded, or drain the device.**

⚠ WARNING

Caution!CO₂ evaporators, of the CPGHN.2 series work with a very high operating pressure. Danger from high operating pressure: 50 bar! Breaks in pressurised tubes or pressurised components of the unit can cause injuries or damage to property caused by flying debris ([see Residual hazards caused by pressurised parts, page 27](#)).

NOTICE

With shutdown times of a month or longer put the fans into operation for approx. 2-4 hours a month to maintain their functionality.

8.4 Shutting the unit down

⚠ WARNING

Danger of injuries and damage to property!

Escaping CO₂ refrigerant can cause injuries ([see Residual hazards due to carbon dioxide \(CO₂\), page 25](#), and [see Residual hazards caused by pressurised parts, page 27](#)).

Ensure that the maximum operating pressure is not exceeded after the shutdown either!

Caution!CO₂ evaporators, of the CPGHN.2 series work with a very high operating pressure. Danger from high operating pressure: 50 bar! Break in pressurised pipes or pressurised components of the unit can cause injuries or damage to property caused by escaping materials ([see Residual hazards caused by pressurised parts, page 27](#)).

NOTICE

Danger of corrosion and dirt build-up!

Moisture and dirt must be prevented from entering the unit.

Protect the unit against dust, contamination, moisture and wetness, damage and other harmful influences ([see Safety instructions for set-up and start-up, page 39](#)).

With shutdown times of a month or longer put the fans into operation for approx. 2-4 hours a month to maintain their functionality.

- ▶ Take the unit out of operation ([see Taking the unit out of operation, page 59](#)).
- ▶ Secure the unit:
 - When shutdown consider max. operating pressure ([see Technical data, page 32](#))! If necessary, take precautions so that it cannot be exceeded.
 - Secure the fan motor drives and, where applicable, the heater rods with electric defrosting against switching on again.

- Secure working fluid-carrying lines against pressurizing with working fluid.
- Protect against damaging effects at the set-up point or intermediate storage location ([see Safety instructions for set-up and start-up, page 39](#)), so that the unit's components are kept properly looked after and the proper intentional use and usability of the unit are maintained. The corresponding storage conditions must be provided for this ([see Storage before installation, page 37](#)); precautionary corrosion protection measures, regular checking of the fans' functionality and regular checks on the shutdown unit.
- ▶ Evacuate the unit: Completely release working fluid and, if applicable, refrigerator oil ([see Residual hazards with disposal, page 30](#)).

8.5 Putting the unit into operation after a shutdown

The unit must be put back into operation after a shutdown in acc. with the system-specific set-up in acc. with the operating instructions manual as follows:

- ▶ Test the unit's readiness for operation ([see Test readiness for operation, page 57](#)). Perform pressure test and visual inspection for corrosion protection.
NOTE! The pressure test with recommissioning must only be carried out with appropriate media at appropriate test pressure.
- ▶ Caution! Low permissible water content in a CO₂ system! Ensure that the unit's level of dryness corresponds with the low permissible water content in a CO₂ system!
- ▶ Put the unit into operation ([see Putting the unit into operation, page 59](#)).

8.6 Changing the unit over to another working fluid

⚠ WARNING

Danger of injuries and damage to property!

Considerable dangers can be caused with operation with another working fluid without prior manufacturer approval ([see Improper use, page 20](#)).

Without prior written consent from Guntner GmbH & Co. KG, the unit must not be changed over to use a different working fluid.

- ▶ Ensure that the unit manufacturer has agreed to the changeover.
- ▶ Ensure that the right working fluid is re-filled. Ensure that all materials used in the unit are compatible with the new working fluid.
- ▶ Ensure that the permissible pressure is not exceeded.
- ▶ Check that the new working fluid can be used without requiring a new test certificate for the unit. Ensure that classification is complied with.
- ▶ The safety device for the unit must be swapped out or reset.
- ▶ Mixtures with residues of working fluid and oil, for example, must be prevented.
- ▶ All information concerning the new working fluid must be changed accordingly.
- ▶ The complete documentation, including these operating instructions and the system operating instructions manual must be changed accordingly.
- ▶ Perform acceptance test ([see Perform acceptance test, page 56](#)).

9 Troubleshooting

9.1 Safety

⚠ WARNING

Danger of injuries and damage to property!

Faults that are not described in these operating instructions may be resolved only by Guntner. Contact the Guntner hotline.

Faults that are described in these operating instructions must only be removed by appropriately trained personnel ([see Personnel, care requirements, page 18](#)).

If any faults occur during the operation, monitoring or maintenance of the system as a whole, inform Guntner GmbH & Co. KG immediately.

9.2 Service

Office hours

Tel. +49 8141 242-473

Fax. +49 8141 242-422

Email: service@guentner.de

Mon-Thurs: 7.30 am - 5 pm

Fri: 7.30 am - 1.30 pm

9.3 Troubleshooting table

Fault	Possible cause(s)	Remedy
Fan motor not running	Power supply interrupted	Restore power supply
	Fan blade stuck	Enable fan to rotate freely
Bearing noises	Defective fan motor	Renew bearing or fan motor
Unit vibrating	Defective fan blades	Change fan blades
	Loose fan fixture	Tighten fixtures
Unit capacity not achieved	Heat exchanger is very dirty, frosted, iced on the air side	Clean, defrost heat exchanger
	Fans not running properly or down	Repair, exchange fans
	Working fluid pressurising defective (temperature and quantity insufficient)	Set working fluid pressurising values (temperature and quantity) to reference values.
Working fluid escaping	Unit working fluid-carrying components leaking	Switch off working fluid feed and fans, close leak

10 Maintenance

10.1 Safety

10.1.1 Before starting all maintenance

WARNING

Danger of injuries and damage to property with escaping working fluid! [see Residual hazards due to carbon dioxide \(CO₂\), page 25](#)).

At 50 % CO₂, is one of the most significant anthropogenic greenhouse gases!

Only perform maintenance work – especially welding work – on the leaking unit after completely removing the working fluid from the unit!

Perform the following safety measures before beginning all maintenance work:

- drain the unit's heat exchanger
- Clean and blow out the unit's heat exchanger.

CO₂ evaporators of the CPGHN.2 series work with a very high operating pressure. Danger from high operating pressure: 50 bar! Breaks in pressurised tubes or pressurised components of the unit can cause injuries or damage to property caused by flying debris ([see Residual hazards caused by pressurised parts, page 27](#)).

10.1.2 With all maintenance work

WARNING

Danger of injuries and damage to property with escaping CO₂ refrigerant!

Escaping refrigerant with leaks on the evaporator can cause the following hazard situations and injuries:



Warns against fire-risk substances at set-up point.

Unintentionally carried in oil residues can ignite.



- Ensure that there is no unintentionally carried in oil in the set-up room .

- Keep the risk area free of direct and indirect ignition sources.

- Before releasing for maintenance obtain the required approvals for work for the unit that can involve ignition sources (e.g. grinding, welding, soldering, etc.).

- With all work involving ignition sources (e.g. grinding, welding, soldering, etc.) in the work area, keep suitable fire extinguishing equipment that meets the requirements of EN 378-3 at hand.

- Do not bring any open flames or hot gases (e.g. candles, matches, welding beads, welding sparks, glowing cinders or tobacco) into the set-up room.

- Ensure that there are no warmed up or hot surfaces (e.g. heaters, hotplates, bulbs, motor housings) in the set-up room.

- Ensure that no frictional heat develops in the set-up room (e.g. overheated stores).



CO₂ evaporators, of the CPGHN.2 series work with a very high operating pressure.

Danger from high operating pressure: 50 bar!

Breaks in pressurised tubes or pressurised components of the unit can cause injuries or damage to property caused by flying debris ([see Residual hazards caused by pressurised parts, page 27](#)).



Warns against health-endangering irritants in the set-up room!

NH₂ refrigerant under defervescence still present can evaporate. Inhalation of refrigerant vapour causes irritation of the respiratory centre, agitation, dizziness and vomiting.



- Escaping refrigerant vapour and escaping refrigerant liquid must not reach adjacent rooms, staircases, yards, passages or drainage systems.
- Use respiratory protection.
- Use a room air-independent breathing apparatus with maintenance work in high CO₂ refrigerant concentrations in the room air.
- Ensure the set-up room is well ventilated.
- Divert escaped refrigerant vapour and escaped refrigerant liquid safely.



Warns against cold!

NH₂ refrigerant still under defervescence has a temperature of -57 °C. Contact with NH₂ refrigerant still under defervescence caused by spraying causes frostbite.



- Use eye protection!
- Use hand protection!



- Ensure that the unit in question is pressure-free before maintenance work begins or the working fluid is sucked up from the unit in question.
- Power off the electrical system and secure it against unintentional switching on again.
- Separate the unit to be maintained from the system and secure it.

NOTICE



Danger of damage to property!

With work in the inlet and outlet feeds of the fans and heat exchanger, objects can get into the fans and therefore cause faults and damage on the components.

- Power off the fans and, where applicable, the heater rods with electric defrosting (option: accessory at customer's request) before beginning maintenance work and secure them against switching on again.
- After the work has finished do not allow any objects to get back into the inlet and outlet feeds of the fans or the set-up room.

10.1.3 After all maintenance work

⚠ WARNING

Danger of injuries and damage to property with escaping CO₂ refrigerant ([see Residual hazards due to carbon dioxide \(CO₂\), page 25](#))!

Perform the following safety measures after finishing all maintenance work:

- Ensure the switching and activation devices, the measuring and display devices and the safety devices function properly.
- Ensure the working fluid fittings are functioning.
- Ensure that the swivel fan units (optional) and the hinged side covers are fixed in their original position and secured against unintentional or unauthorised opening.
- Check the identification of the pipelines and ensure this is visible and legible.
- Check the fixing and corrosion protection of the components in question.
- Ensure the electrical connections (e.g. fans and, where applicable, the heating rods with electrical defrosting) are functioning.
- Ensure the temperature and air humidity at the set-up point are the same as that in the order-related offer documents.
- Perform a pressure test and a tightness test (see operating instructions manual annex).
- **Caution!** CO₂ evaporators of the CPGHN.2 series work with a very high operating pressure. Danger from high operating pressure: 50 bar! Breaks in pressurised tubes or pressurised components of the unit can cause injuries or damage to property caused by flying debris ([see Residual hazards caused by pressurised parts, page 27](#)).
- **Caution!** Low permissible water content in a CO₂ refrigeration system! Ensure that the unit's level of dryness corresponds with the low permissible water content in a CO₂ refrigeration system!
- Perform an acceptance test ([see Perform acceptance test, page 56](#)).
- Perform a pressure test (see operating instructions manual annex).

10.2 Inspection and maintenance plan

Regular checks of all the safety-related parts of the system are an essential part of fulfilling all requirements. Repeated tests must be performed either by a “qualified person” as defined in § 2, section 7 of the German Ordinance on Industrial Safety and Health (BetrSichV), or by a certified inspection agency. The operator must determine the test intervals for the complete system and the system components on the basis of a safety-related evaluation. Nevertheless, as with every technical installation, whereby it can generally be said the most frequent causes are not material errors, but operating errors, certain incidents cannot be ruled out.

The checks to be performed are listed in the following sections as time-scaled checklists.

10.2.1 Fans

The manufacturer's operating specifications take priority for this component. Güntner GmbH & Co. KG recommends proceeding according to the following inspection and maintenance plan:

d = daily, w = weekly, m = monthly, y = yearly				
Work to be performed	d	w	m	y
Check fans for dirt, frost and ice build-up. <ul style="list-style-type: none"> • With dirt build-ups: Clean fans (see Clean unit, page 68). • With frost and ice build-ups: Defrost the unit (see Defrosting the unit, page 73). 	X			
Check the fan drive for smooth running. <ul style="list-style-type: none"> • Vibrations on the unit: remove imbalances • Where required, tighten and correct blade fixtures and blade settings 				X *
Fan bearing: Running sound and smoothness changes <ul style="list-style-type: none"> • Exchange bearing 				X *
Fan motor: Is a new bearing due? <ul style="list-style-type: none"> • Exchange bearing or motor; where applicable, clean and repair motor 				X *
Fan wheel: corrosion on bolts (with threaded blades) <ul style="list-style-type: none"> • exchange bolts 				X *
Fan blades: Corrosion or damage on blades <ul style="list-style-type: none"> • Exchange blades or wheel 				X *
Fan swivel unit (optional): Fixture loose <ul style="list-style-type: none"> • Tighten fixture (see Notes on mounting fan swivel unit (option), page 49). 				X *
Fan swivel unit (optional): Corrosion on fixture <ul style="list-style-type: none"> • Renew fixture (see Notes on mounting fan swivel unit (option), page 49). 				X *

*) Recommended: every six months

10.2.2 Unit heat exchanger

WARNING

Danger of injuries and damage to property with escaping CO₂ refrigerant ([see Residual hazards due to carbon dioxide \(CO₂\), page 25](#))!

Caution! CO₂ evaporators, of the CPGHN.2 series work with a very high operating pressure. Danger from high operating pressure: 50 bar! Breaks in pressurised tubes or pressurised components of the unit can cause injuries or damage to property caused by flying debris ([see Residual hazards caused by pressurised parts, page 27](#)).

Perform a regular external check (visual inspection) on the unit every 5 years. Güntner AG & Co. KG recommends you have this test performed by an expert.

d = daily, w = weekly, m = monthly, y = yearly				
Work to be performed	d	w	m	y
Check heat exchanger for dirt, frost and ice build-up. <ul style="list-style-type: none"> • With dirt build-ups: Clean heat exchanger (see Clean unit, page 68). • With frost and ice build-ups: Defrost the unit (see Defrosting the unit, page 73). 				X*
Check heat exchanger's general condition. <ul style="list-style-type: none"> • Damage found: Repair damage 				X*
Check heat exchanger's operating point (see Operation, page 59). <ul style="list-style-type: none"> • Change in fan capacity found: restore required system-side conditions . • Change in surface temperatures found: restore required system-side conditions . 				X*
Check heat exchanger and connections for tightness. <ul style="list-style-type: none"> • Repair unit sections (see Remove leaks, page 68). 				X*
Check heat exchanger for working fluid pressurising. <ul style="list-style-type: none"> • Restore required system-side conditions. 				X
Check heat exchanger for corrosion. <ul style="list-style-type: none"> • Corrosion or damage on core tubes, fins, support structures, tube connections, fixtures: repair unit sections affected. 				X*

*) Recommended: every six months

Care and maintenance plan

Measure	Cleaning agent	Interval
Remove frost and clean component	Mechanically	As required (visual inspection)
Heat exchanger defrosting	Circulation air, electric, hot gas ; automatic defrosting device; defrost locking device (flap, Shut-Up)	According to local conditions (penetrating moisture, air or chilled goods); with an ice thickness of 1 mm at the latest.
Complete cleaning	Warm water or environmentally safe cleaning agent	After 120 hours
Leak check		After 6 months
Corrosion protection check		After 6 months
Clean the heat exchanger (only applies to units with the HydroSpray system) Clean the heat exchanger (only applies to units with the HydroSpray system)	see Hydraulic cleaning, page 70	Monthly

10.3 Maintenance work

10.3.1 Remove leaks

⚠ WARNING

Danger of injuries with CO₂ refrigerant ([see Residual hazards due to carbon dioxide \(CO₂\), page 25](#))!

- Have leaks removed as quickly as possible by an expert.
- Do not fill with a working fluid other than that specified in acc. with the order-related offer documents!
- Only put the unit back into operation when all leaks have been repaired.

Caution! CO₂ evaporators of the CPGHN.2 series work with a very high operating pressure. Danger from high operating pressure: 50 bar! Breaks in pressurised tubes or pressurised components of the unit can cause injuries or damage to property caused by flying debris ([see Residual hazards caused by pressurised parts, page 27](#)).

Warning! Low admissible water content in a CO₂ plant! Ensure that the desiccation ratio of the unit complies with the low admissible water content in a CO₂ system.

- ▶ Perform all work including pressure, acceptance and functional test ([see Perform acceptance test, page 56](#), and [see Test readiness for operation, page 57](#)).

10.4 Clean unit

10.4.1 General

The following applies for cleaning: The operator must ensure that the cleaning agents are environmental friendly and compatible for the materials in the system. Harmful to the environment substances, e.g. acid-forming, are forbidden.

When used in HACCP-certified rooms, the unit must be included in the specified cleaning processes.

ACHTUNG - ATTENTION - ATTENTION - ATE

<p>Bei der Verwendung von Reinigungsmitteln in Kühlräumen, ist auf die Korrosionsbeständigkeit der Materialien des Kühlers gegenüber dem verwendeten Reinigungsmittel zu achten!</p>	<p>When cleaning agents are used inside the cold room, the corrosion resistance of the cooler materials to the applied cleaning agent has to be observed!</p>	<p>Lors de l'utilisation des détergents dans les chambres froides, il faut observer à la résistance à la corrosion des matériaux de l'appareil qui entrent en contact direct avec les détergents.</p>	<p>Cuando se apliquen agentes limpiadores en los productos instalados en cámaras frías, se debe tener cuidado que no corraen los materiales usados para la construcción del producto!</p>
--	---	---	---

- ▶ Clean casing by rinsing with warm water (approx. +25°C) and/or with environmentally friendly cleaning agents.
- ▶ Rinse thoroughly with water after using cleaning agents.
- ▶ Allow casing to dry completely.
- ▶ Check working fluid-side and electrical connections ([see Test readiness for operation, page 57](#)).

10.4.2 Removing the drip tray and side cover

The drip tray and the side cover can be removed for cleaning and maintenance purposes. The drip tray has a safety catch, which must be removed for this.

Proceed as follows:

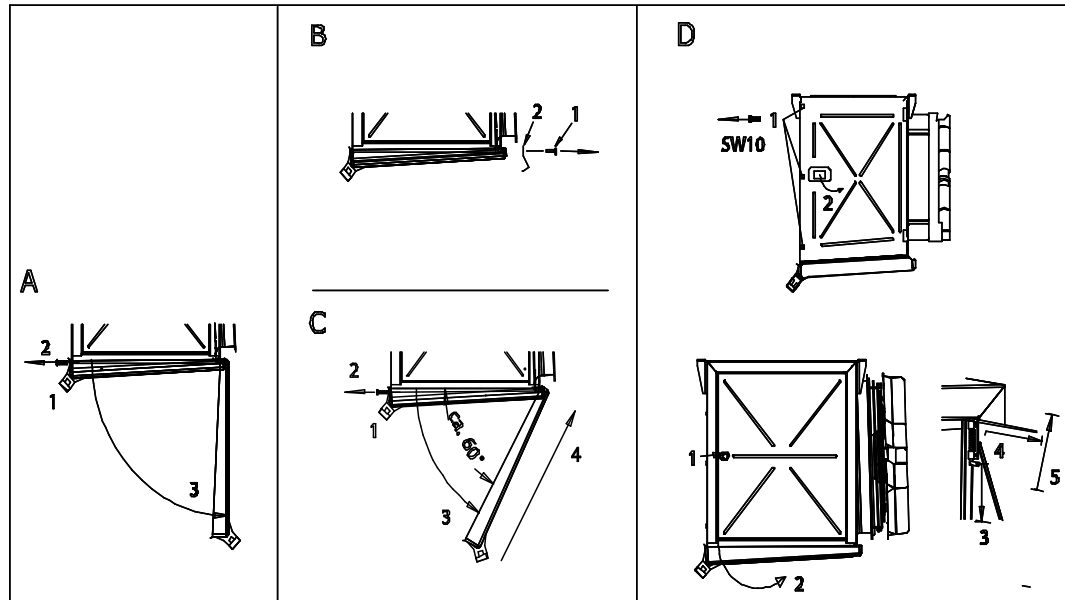

Remove the drip tray and side cover

How to:	
A	Flap drip tray down
1	Unscrew drain
2	Loosen screw
3	Flap tray down
B	Remove holding bracket
1	Loosen screw
2	Remove holding bracket
C	Unhinge tray
1	Unscrew drain
2	Loosen screw
3	Flap tray down
4	To unhinge tray: Push tray upwards
D	Unhinge side cover
1	Loosen screws (SW 10)
2	Open side cover
3	Pull spring pin down
4	Swing side cover outwards
5	Lift and remove side cover

10.4.3 Clean and defrost heat exchanger

With the swivel fan units (optional), with a few simple turns openings are provided for better cleaning of the heat exchanger coil.

- ▶ Drain the unit (see system).
- ▶ Shut off the unit (see system).
- ▶ Power off the fans (see system).
- ▶ Perform defrosting (see system).
- ▶ Clean the heat exchanger with one of the following procedures:
 - Cleaning with compressed air ([see Cleaning with compressed air, page 70](#)).
 - Hydraulic cleaning ([see Hydraulic cleaning, page 70](#)).

NOTICE

Danger of damage to property!

The fins can be damaged with too high a pressure, too small a distance or a cleaning jet that hits the fins at an angle. Mechanical cleaning with hard objects (e.g. steel brushes, screw drivers, or similar) damages the heat exchanger.

- Use a pressure of max. 50 bar with hydraulic cleaning and max. 80 bar with cleaning with compressed air!
- Maintain a minimum distance from the fins of 200 mm!
- Always aim the jet vertically (max. ± 5 degree deviation) at the fins!
- Do not use any hard objects when cleaning!
- ▶ Fix the swivel fan units (option) in their original position and secure against unintentional or unauthorised opening.
- ▶ Switch fans on (see system).
- ▶ Open suction side (see system).
- ▶ Open working fluid feed (see system).

10.4.3.1 Cleaning with compressed air

- ▶ Blast heat exchanger (max. 80 bar pressure) with compressed air to remove dirt and contaminants.

NOTE! Hold the jet of the cleaner vertical to the fins (max. deviation of ± 5 degrees) to prevent fins from bending.

10.4.3.2 Hydraulic cleaning

⚠ WARNING



Warns against dangerous electrical voltage!

Direct and indirect contact with voltage-carrying parts of motors and electrical lines can cause serious injuries or death. Water and cleaning agents conduct electricity.

- Power off the fans for cleaning with water or steam and where applicable the heater rods for electrical defrost (option; accessory on customer request and ensure them against switching on again).

NOTICE

Danger of damage to property!

Water or steam jets can damage fans, electrical lines or other components.

- Ensure that electrical connections and motors, as well as components and stored goods at the set-up point are not touched by water or steam jets. Cover these if required.
- ▶ Heavier moisture or greasy dirt must be removed with a high-pressure water jet (max. 50 bar pressure), steam pressure jet (max. 50 bar pressure), min. 200 mm distance with flat jet nozzle, or using neutral cleaning agent where applicable, always against the airflow direction. Ensure here:
 - With oily and greasy dirt it helps to add a cleaning agent to the water.
 - When applying chemical agents ensure that they are not aggressive towards the unit's materials. Rinse the unit off after the treatment.
 - Cleaning should be done from inside to the outside (but always opposing the dirt onset) and from top to bottom, so that the dirt can be removed without returning.
 - Hold the jet of the cleaner vertical to the fins (heat exchanger – max. deviation of ± 5 degrees) to prevent fins from bending.

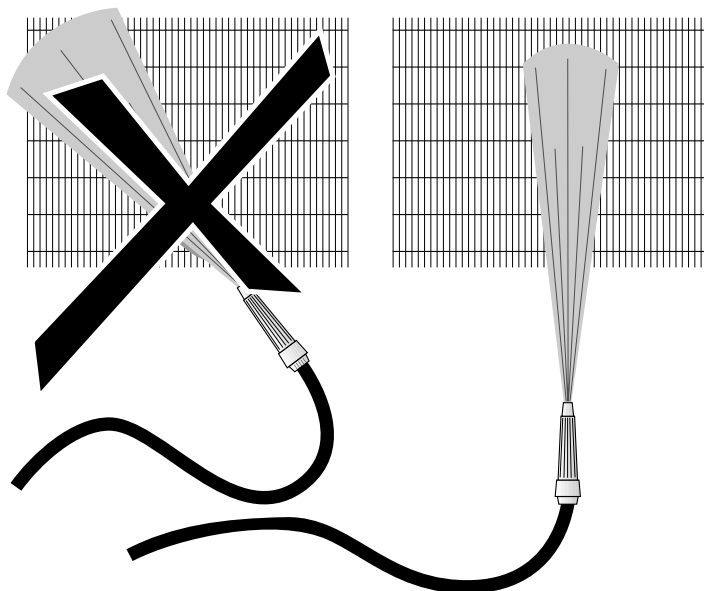

- ▶ Continue cleaning until all dirt has been removed.

10.4.4 Cleaning fans

⚠ WARNING

Danger of cutting off, pulling in!

There is a danger of cutting off fingers on the rotating fan blades, injury hazard for the hands and pulling in danger for loose elements such as hair, necklaces or clothing parts.

- Power off the unit before you begin maintenance work. Secure the unit against unintentional switching on again by removing the electric fuses for the unit. Secure the unit with a suitable warning sign referring to unintentional switching on.
- Put fans and guard grilles that were removed or opened for maintenance back into their original status without fail before you put the unit back into operation!

Dirt build-ups and frost and/or icing on the fans and the fan guard grilles must be removed regularly, otherwise they will cause imbalances or destruction and power losses. The fan motors themselves are maintenance-free.

- ▶ Power off the unit and secure it against unintentional switching on.
- ▶ Clean fans with one of the following procedures:
 - NOTE! Danger of damage to property! Mechanical cleaning with hard objects (e.g. steel brushes, screw drivers, or similar) damages the fan. Forbidden!**
 - Cleaning with compressed air: Blow fans with compressed air (max. 10 bar pressure; min. distance 200 mm) to remove dirt and contaminants. Continue cleaning until all dirt has been removed.
 - Cleaning with compressed air and brushes: Remove dry dust or dirt with a brush, a hand brush or with compressed air (max. 10 bar pressure, min. distance of 200 mm) or with a powerful industrial vacuum cleaner. Ensure here: use soft brushes (no steel brushes or similar)! Continue cleaning until all dirt has been removed.
- ▶ Mount guard grille
- ▶ Switch unit on

Note for swivel fans

With units with swivel fans (option), these should be swung out for better cleaning. The motors must, however, also be protected here from being sprayed.

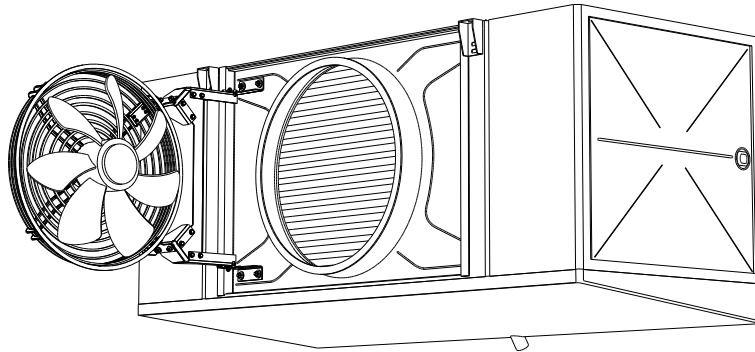

After cleaning the swivel fans must be put back to their original position and fixed and secured here against unintentional or unauthorised opening.

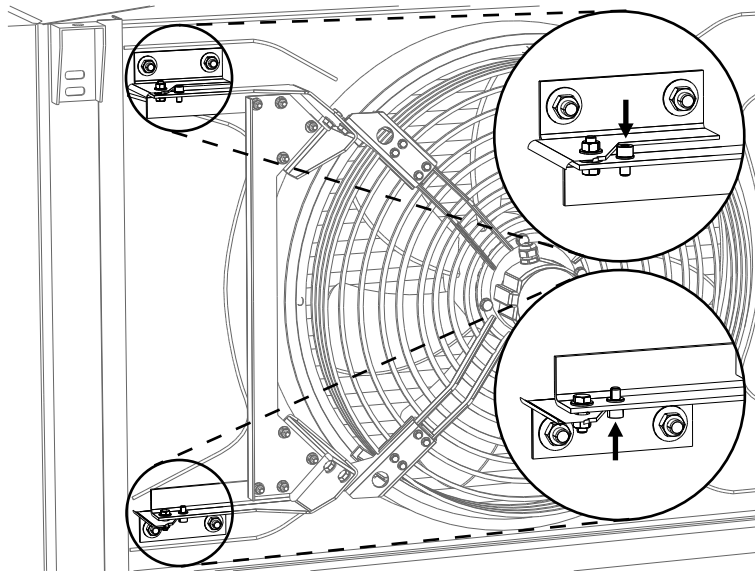

10.5 Defrosting the unit

10.5.1 Notes on defrosting

WARNING

Warning against personal injury and damage to property!

Danger of falling unit parts, masses of water or ice when the drip tray is flapped out.

Nobody is allowed to be in the danger area below the unit during cleaning or maintenance work. The drip tray can be flapped down for cleaning and is protected from falling down by a safety catch. Unit parts, masses of water or ice can nonetheless fall down when it is flapped down.

Defrosting the unit at the correct times guarantees continuous operational reliability and the prevention of inaccessibilities that could result in a shutdown and disruptions. As the local conditions have a very big influence of the unit's performance and the need for defrosting, the operation must be checked regularly and specifically for frost and/or icing on the heat exchanger. The following notes apply for defrosting the unit:

- Regularly check for frost and/or icing. With a frost thickness of max. 1 mm per fin side the unit must be defrosted to be able to guarantee fault-free operation.
- Defrosting process must start in good time.

The defrosting frequency depends on the effects of penetrating moisture (e.g. cold storage room door) or introduced moisture (e.g. goods to be cooled, .). It must be noted here that the temperature difference between the working fluid and the air inlet temperature is critical for the defrosting frequency:

- Unit with greater temperature difference: Frequent defrosting
- Unit with lesser temperature difference: Less defrosting

Alternating operating states, e.g. usage changes at the set-up point, must also be considered. The defrosting frequency can be influenced by effects on the air side. Insufficient unit-wall distance, distance between two opposing units too low, underdraughts shortly before the air outlet, incorrect goods storage (too high, no wall distance, across the airflow direction) cause increased defrosting frequency.

Defrosting completeness

When finishing the defrosting process you must ensure that the defrosting is absolutely complete. Selecting the right defrosting temperature is an important requirement in this respect.

- If the defrosting temperature is set too low this impairs the unit's effectiveness from one defrosting to another with the removal of "ice-spots".
- If the defrosting temperature is set too high this causes extreme water vapour formation, which causes frost and ice to form around the unit.

Settling time

A period (approx. 5 to 8 minutes) between when the defrosting finishes and when the unit is activated has been proven to be necessary, as the unit's heat exchanger can drip off completely and the defrosting water can flow away through the drip water tray drain during this period.

Delayed fan start

If the fans' activation is delayed by a further period (approx. 3 to 5 minutes), then the defrosting heat from the heat exchanger is absorbed and it is not given off into the room as warm-moist air.

10.5.2 Defrost control

- The defrosting process is started at pre-set intervals or as required.
- The process completion must be ensured twice (time/temperature and temperature/temperature),
- For defrost operation (circulation air, electric – optional; accessory available at customer's request), hot gas (optional)) the correct on-site installation of the defrosting sensor must be ensured. See defrosting procedure listed below.
- Recommendation – perform the defrosting process at the following times:

Electric defrosting (optional)(accessory available at customer's request)

Cold operation	X					
Suction operation		X				
Defrost operation			X			
Drip phase				X		
Freeze on phase					X	
Cold operation						X
Fans	Operation	Operation	Off	Off	Off	Operation

The duration of the individual phases depends from a variety of factors (e.g. temperature, moisture, etc.) in the particular application.

Hot gas defrosting (option)

Cold operation	X					
Suction operation		X				
Defrost operation			X			
Drip phase				X		
Freeze on phase					X	
Cold operation						X
Fans	Operation	Operation	Off	Off	Off	Operation

The duration of the individual phases depends from a variety of factors (e.g. temperature, moisture, etc.) in the particular application.

10.5.3 Circulation air defrosting

With operation of the units at room temperatures in the plus range (plus-cold storage rooms) and evaporation temperatures $t_0 = 0$ to -5°C , circulation air defrosting is usually sufficient: with shut-off working fluid-carrying lines the required defrosting heat is generated by the fan heat flow and the air temperature in the plus range. But it also applies here: the refrigerating operation may be restarted, as described, only after complete defrosting.

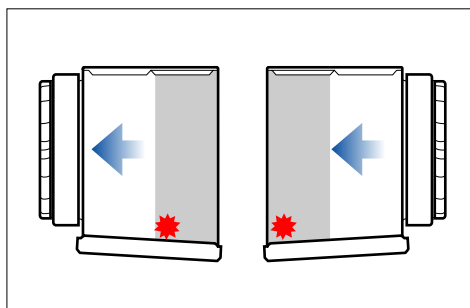

Recommended defrosting sensor positioning

10.5.4 Electric defrosting (optional)(accessory at customer's request)

With several units per room with electric defrosting alternating defrosting should be avoided, as otherwise reciprocal influences can have a negative effect here. These influences result on one hand from the extraction of the heat from the units to be defrosted and therefore in a defrost delay, and on the other hand in an additional stress with heat and moist air on the units in refrigerating operation. Group defrosting is recommended instead of alternating. Several units are grouped here into a defrosting group. If a group is now defrosted, the other groups must be switched off. This means that with a temperature increase in the room, which is not above the alternating defrosting one, the reciprocal influencing of the units is limited to a minimum, as described above.

The following must be ensured here: With alternating defrosting within a room (group defrosting), use defrost closure devices (defrost flaps, textile closure devices)! An on-site monitoring with a safety device (temperature limiter; to be planned for in creating the annex) must be provided in acc. with EN 60519-2; VDE 0721; T. 411 to rule out the danger of the units overheating. Operation without a temperature monitor is forbidden! The max. permissible fuse for the electric heating groups with 20 A must be complied with without fail. The min. fusing is provided in the order-related connection diagrams. To prevent the permissible pressure in the unit from being exceeded with electric defrosting systems, in acc. with EN 378-2 either working fluid displacement must be enabled or a suction circuit must be provided.

A separate control of the coil and tray defrosting is possible (see note in electric connection plan).

With average usage conditions a reduced defrosting capacity in the coil can be adjusted with a simple wiring change (see separate electric connection plan).

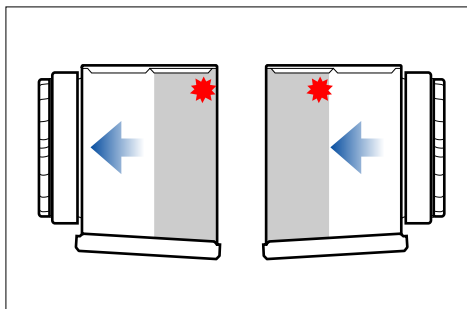

Recommended defrosting sensor positioning

10.5.5 Hot gas defrosting (option)

⚠ WARNING

Danger of high pressure with hot gas defrosting!

Hot gas defrosting is the most effective defrosting method, especially with low temperatures, but it requires the highest pressures!

A defrosting temperature of +9°C can be achieved with a maximum permissible operating pressure of 50 bar. The saturation pressure at +9°C is approx. 44 bar. Added to this is another approx. 10% for the safety valve and approx. 5% for system pressure fluctuations, resulting in the max. permissible operating pressure of 50 bar (see graphic below).

This defrosting method can, however, only be used with CO₂ refrigeration systems specially configured for this operating pressure.

- The given +9°C defrosting temperature must not be exceeded!

With defrosting with hot gas it must be ensured that at the point of defrosting enough other consumers are in the cold operation so that a big enough hot gas volume is available (approx. 2-3 times the defrosting power compared with the cooling capacity can be expected as reference value).

It must, however, be ensured here that with alternating defrosting within a room defrost closure devices must always be used (defrost flaps, textile closure devices). The reciprocal influences of units in the refrigeration and cooling units in defrosting operation in conjunction with short defrosting times with hot gas operation are therefore limited to a low range of effect. These influences result on one hand from the extraction of the heat from the units to be defrosted and therefore in a defrost delay, and on the other hand in an additional stress with heat and moist air on the units in cooling/refrigerating operation.

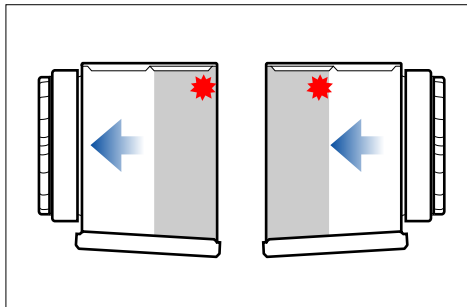

Recommended defrosting sensor positioning

10.5.6 Further notes on defrosting

The drains of the drip trays must be heated (apart from plus-cold storage rooms), so that ice formation is prevented here.

Available defrost closure devices (defrost flaps, textile closure devices must always be used here so that water vapour formation and therefore frost and ice formation do not occur outside the unit coil. For this see "Operating and installation instructions – defrost flap".

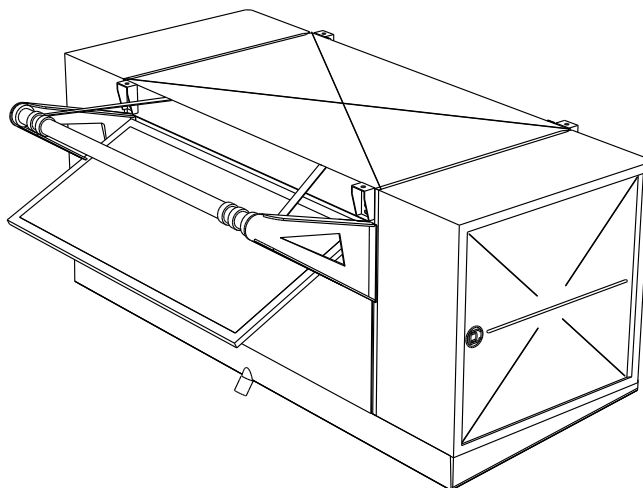

Fabric closure devices may only be used with use of fan ring heaters with reduced heating power and corresponding installation accessories.

NOTICE

The use of textile closure devices (e.g. Shut-Up) results with refrigeration operation in additional pressure losses on the air side. This fact must always be considered with the configuration.

11 Plans/diagrams

11.1 Electrics documentation

11.1.1 Fan motor connection diagram

See motor terminal box cover inside on the fan.

11.1.2 Connection diagram electrical defrost (selectable option; accessory on customer request)

See order-related offer documents